

SIMATIC NET

Commissioning PC Stations - Manual and Quick Start

Manual

Advanced PC Configuration

Preface, Contents

Advanced PC Configuration -
Introduction

1

Getting Started

Configured Mode

2

PG Operation

3

Additional Functions

4

Configuring the OPC Server

5

Examples

Industrial Ethernet

6

PROFIBUS-DP

7

Unspecified S7 Connection

8

SNMP

9

PROFINet

10

Tools

Station Configuration Editor

11

NCM PC

12

PC Station Wizard

13

Symbol File Configurator

14

Configuration Console

15

OPC Scout

16

DCOM Settings

17

Appendix

Classification of the Safety-Related Notices

This manual contains notices which you should observe to ensure your own personal safety, as well as to protect the product and connected equipment. These notices are highlighted in the manual by a warning triangle and are marked as follows according to the level of danger:



Danger

indicates that death or severe personal injury **will** result if proper precautions are not taken.



Warning

indicates that death or severe personal injury **can** result if proper precautions are not taken.



Caution

with warning triangle indicates that minor personal injury can result if proper precautions are not taken.

Caution

without warning triangle indicates that damage to property can result if proper precautions are not taken.

Notice

indicates that an undesirable result or status can occur if the relevant notice is ignored.

Note

highlights important information on the product, using the product, or part of the documentation that is of particular importance and that will be of benefit to the user.

Trademarks

SIMATIC[®], SIMATIC HMI[®] and SIMATIC NET[®] are registered trademarks of SIEMENS AG.

Third parties using for their own purposes any other names in this document which refer to trademarks might infringe upon the rights of the trademark owners.

Safety Instructions Regarding your Product:

Before you use the product described here, read the safety instructions below thoroughly.

Qualified Personnel

Only **qualified personnel** should be allowed to install and work on this equipment. Qualified persons are defined as persons who are authorized to commission, to ground, and to tag circuits, equipment, and systems in accordance with established safety practices and standards.

Correct Usage of Hardware Products

Note the following



Warning

This device and its components may only be used for the applications described in the catalog or the technical description, and only in connection with devices or components from other manufacturers which have been approved or recommended by Siemens.

This product can only function correctly and safely if it is transported, stored, set up, and installed correctly, and operated and maintained as recommended.

Before you use the supplied sample programs or programs you have written yourself, make certain that no injury to persons nor damage to equipment can result in your plant or process.

EU Directive: Do not start up until you have established that the machine on which you intend to run this component complies with the directive 89/392/EEC.

Correct Usage of Software Products

Note the following



Warning

This software may only be used for the applications described in the catalog or the technical description, and only in connection with software products, devices, or components from other manufacturers which have been approved or recommended by Siemens.

Before you use the supplied sample programs or programs you have written yourself, make certain that no injury to persons nor damage to equipment can result in your plant or process.

Prior to Startup

Before putting the product into operation, note the following:

Caution

Before installing and starting the module, read the instructions in the corresponding documentation. For ordering data of the documentation, please refer to catalogs or contact your local Siemens representative.

Copyright ©Siemens AG 2001 -2003 All rights reserved

The reproduction, transmission or use of this document or its contents is not permitted without express written authority. Offenders will be liable for damages. All rights, including rights created by patent grant or registration of a utility model or design, are reserved.

Siemens AG
Automation and Drives
Industrial Communication
Postfach 4848, D-90327 Nürnberg

Siemens Aktiengesellschaft

Disclaimer

We have checked the contents of this manual for agreement with the hardware and software described. Since deviations cannot be precluded entirely, we cannot guarantee full agreement. However, the data in this manual are reviewed regularly and any necessary corrections included in subsequent editions. Suggestions for improvement are welcomed.

Subject to technical change.

G79000-G8976-C156-04

This manual...

... supports you when commissioning your SIMATIC NET PC modules in a PC station and helps you to use them successfully.

... introduces all the tools made available by the SIMATIC NET software for solving your communication tasks.

... along with the OPC documentation on the SIMATIC NET PC / Windows CD answers your questions on all aspects of communication:

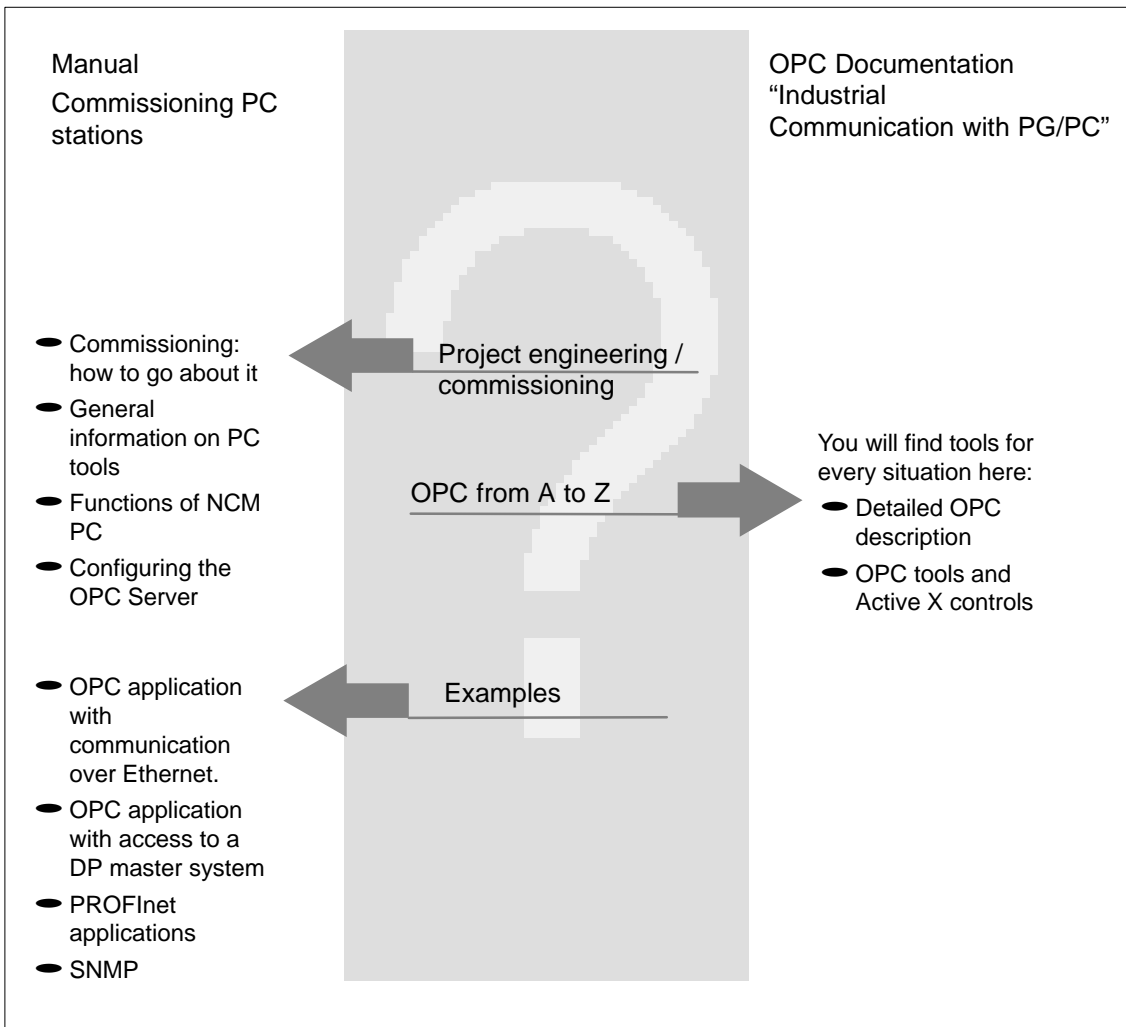

New in this version

This release includes the topic PROFINET IO.

PROFINET as an Ethernet-based automation standard from PROFIBUS International (previously PROFIBUS Users Organization e.V. (PNO)) defines a vendor-independent communication, automation, and engineering model.

The Documentation in the “S7-CPs / NCM S7” Documentation Package and on the Internet

You can order this manual along with other documents in a manual package.

You will find the current version of the manual on the Internet at:

<http://www4.ad.siemens.de/view/cs/de13542666>

Additional Information on SIMATIC S7 and STEP 7

The documentation on SIMATIC S7 and STEP 7 contains additional information on the STEP 7 basic software of the SIMATIC automation system. You can obtain these from your local Siemens office.

Validity of this Manual

The information in this manual applies to

- Version 5.2 and higher of the project engineering software SIMATIC NCM PC / STEP 7 with the NCM S7 option;
- CD 11/2003 and higher from SIMATIC NET

Symbols used in this manual



This symbol appears in the margin to draw your attention to useful tips.



This symbol highlights particularly relevant literature.



HLP

Passages marked with this symbol indicate that there is useful information you should refer to in the basic help of STEP 7.



This symbol indicates that detailed help is available in the context-sensitive help. You can display this with the F1 key or by clicking on the "Help" button in the relevant dialog.

Conventions

References to other manuals and documentation are indicated by numbers in slashes /.../. These numbers refer to the titles of manuals listed in the References section of the Appendix.



Contents

Preface	5
1 Welcome to Advanced PC Configuration	13
1.1 A New Concept for Your Benefit	13
1.2 PC Stations in SIMATIC	15
1.3 A Brief Introduction to Tools and Utilities	18
1.4 Guide to Installation and Commissioning	19
1.4.1 PG Operation or Configured Mode - Considerations	19
1.4.2 Commissioning for PG Operation - Overview	21
1.4.3 Commissioning for Configured Mode - Overview	22
 Getting Started	
2 Getting Started “Configured Mode”	25
2.1 Steps for Initial Configuration	26
2.1.1 Case a) Initial Configuration with XDB File	27
2.1.2 Initial configuration without XDB file	29
2.2 Steps in Creating Project Engineering Data	31
3 Getting Started “PG Operation”	38
3.1 Configuration for PG Operation - Programming Device (PG/PC)	39
3.2 Configuration for PG Operation - HMI Stations	41
4 Using Additional Functions - Special Features to Note	46
4.1 Checking the Configuration and Diagnostics	46
4.2 Testing with the OPC Scout	46
4.2.1 Detecting Errors in Communication with the OPC Scout	46
4.3 Further Functions / Special Features	49
4.3.1 Adopting the Project Engineering and Symbols from PROFINet iMap and SIMOTION Scout	49
4.3.2 Configuring Access Points for STEP 7 and STEP 5	50
4.3.3 Points to Note with SOFTNET Industrial Ethernet Modules	52
5 Project Engineering for the OPC Server	53
5.1 Significance of Project Engineering	54
5.2 Specifying the Properties of the OPC Server in Project Engineering .	55
5.3 Specifying Connection Properties for the OPC Server in Project Engineering	57
5.4 Using Symbols for S7 Connections	61
5.5 Configuring OPC Properties for SNMP in Project Engineering	62
5.5.1 Significance in SIMATIC NET	62
5.5.2 SNMP Traps	63

Examples

6 Example — OPC Application for Industrial Ethernet	65
6.1 Overview	65
6.2 Hardware and Software Installation	67
6.3 Creating the STEP 7 Project	68
6.3.1 STEP 7 Project Engineering on a Central Engineering Station	68
6.3.2 Using Symbol Files	69
6.4 Configuring the PC Station	72
6.5 Using the OPC Scout	76
6.5.1 Establishing a Connection to the Server	76
6.5.2 Inserting a Group and Variables	77
6.5.3 Displaying and Modifying Values of Variables	79
7 Example — OPC Application for PROFIBUS-DP	80
7.1 Overview	80
7.2 Hardware and Software Installation	82
7.3 Configuring the PC Station	83
7.4 Changing the configuration on the PC station	86
7.4.1 Changing the Hardware Configuration - Preparations	86
7.4.2 Inserting a DP Master System	88
7.4.3 Inserting a DP Slave	89
7.5 Using the OPC Scout	91
7.5.1 Establishing a Connection to the Server	91
7.5.2 Inserting Groups and Variables	92
7.5.3 Displaying and Modifying Values of Variables	93
8 Example — Unspecified Connection from a PC Application	95
8.1 Overview	95
8.2 Installing the Software	96
8.3 Configuring the PC Station	97
8.4 Creating, Editing and Downloading a STEP 7 Project	102
8.4.1 Creating a New Project	102
8.4.2 Edit the Network and Connection Project Engineering Data	104
8.4.3 Downloading the Project Engineering Configuration	110
8.5 Configuration Console	112
9 Example — SNMP Communication with OPC	114
9.1 Hardware and Software Installation	115
9.2 Configuration of the SNMP OPC Server	116
9.2.1 Editing the Plant Configuration	118
9.3 Configuring the PC Station	121
9.4 Using the OPC Scout	124
9.4.1 Establishing a Connection to the Server	124
9.4.2 Inserting a Group	125

9.4.3	Setting the Trap Recipient based on the Example of an OSM/ESM . . .	127
9.5	Creating a Device Profile with the MIB Compiler	129
10	Example — PROFINet Communication with OPC	133
10.1	Hardware and Software Installation	134
10.2	Configuring the PC Station	135
10.3	Using Symbol Files	137
Tools and Utilities		
11	Station Configuration Editor Tool	139
11.1	Characteristics, Functions and Activation	139
11.2	Managing Components: “Components” Tab	140
11.3	Evaluating Messages: “Diagnostics” Tab	144
11.4	Setting the Station Configuration Editor: “Properties” Dialog	144
12	SIMATIC NCM PC Project Engineering Tool	146
12.1	Characteristics, Functions and Activation	146
12.2	Relationship Between SIMATIC NCM PC and STEP 7	149
12.3	Creating a PC Station	151
12.4	Configuring a PC Station with SIMATIC NCM PC Config	154
12.5	Creating the DP Master System	157
12.6	Creating a PROFINET IO System	159
12.7	Configuring Connections	161
12.8	Downloading Project Engineering Data to the PC Station (after Initial Configuration)	163
12.8.1	Online Mode	164
12.8.2	Offline Mode (Engineering Station and Runtime PC Separate) - XDB Import	166
12.9	Adapting Mismatched Configurations	168
13	PC Station Wizard	169
14	Symbol File Configurator Tool	171
14.1	Characteristics, Functions and Activation	171
14.2	The Meaning of Symbols	174
14.3	Menus of the Symbol File Configurator in Detail	176
14.4	Managing Symbols	178
14.4.1	How to Insert a New Symbol	178
14.4.2	How to Insert a New Folder	179
14.4.3	How to Add a Name Space Prefix	180
14.4.4	How to Delete Folders or Symbols	180
14.4.5	How to Import a Symbol File	180

14.4.6	How to Export a Symbol File	181
15	Configuration Console Tool	182
15.1	Characteristics, Function and Activation	182
15.2	Support During Commissioning and Operation	184
15.2.1	Triggering a Restart on the Module	184
15.2.2	Forcing the OPC Server to Close Down	186
15.2.3	Activating Configured Protocols Step by Step	188
15.2.4	Setting a Symbol File for OPC	190
15.2.5	Setting Traces	192
15.3	Editing the Configuration	196
15.3.1	Changing the Mode of a Module	196
15.3.2	Displaying and Setting the Industrial Ethernet Network Parameters for a CP 1613	198
15.3.3	Setting the Industrial Ethernet Station Addresses	200
15.3.4	Assigning Access Points to the Individual Modules	201
15.3.5	Setting the PROFIBUS DP Slave	203
15.4	Diagnostics with "Configuration Console"	205
15.4.1	Displaying the Operability of a PROFIBUS Module	205
15.4.2	Displaying the Industrial Ethernet Network Parameters for a CP 1613	207
15.4.3	Displaying PROFIBUS Network Nodes	208
15.4.4	Displaying PROFIBUS Network Parameters	210
15.4.5	Displaying Version Information of Hardware and Firmware	211
16	OPC Scout	212
16.1	Characteristics, Functions and Activation	212
16.2	Connecting the OPC Scout to a Local Server	214
16.3	Connecting the OPC Scout to a Remote Server	214
16.4	Create a Group	215
16.5	Browsing the Process Space - OPC Navigator	215
16.6	Create New Variables	217
16.7	Adding and Monitoring Variables	217
16.8	Customizing the Display	218
16.9	Display Attributes	219
16.10	Change Values	220
16.11	Menus of the OPC Scout in Detail	220
16.11.1	File Menu	220
16.11.2	View Menu	221
16.11.3	Server Menu	221
16.11.4	Group Menu	222
16.11.5	Item Menu	222
16.11.6	? Menu	223
17	DCOM Settings with the dcomcnfg System Program	224
17.1	Characteristics, Functions and Activation	224

17.2	"Default Properties" Tab	227
17.3	"Default Security" Tab	229
17.4	DCOM Configuration / "Applications" Tab	231
17.5	"Default Protocols" Tab	232
17.6	Configuration of the Server Computer	233
17.6.1	"General" Tab: Registering the OPC Server	234
17.6.2	"Location" Tab	235
17.6.3	"Identity" Tab	236
17.6.4	"Security" Tab	238
17.7	Configuration of the Client Computer	243
Appendix		
A	Notes for Users of Older Versions	247
A.1	LDB and XDB Databases - Overview	247
A.2	Project Engineering up to SIMATIC NET CD 05/2000	248
A.3	Continued Use of Previous Project Engineering	250
A.4	Industrial Ethernet - Effects on Older Product Versions (SIMATIC NET CD 05/2000 and earlier)	251
A.5	PROFIBUS - Effects on Older Product Versions (SIMATIC NET CD 05/2000 and earlier)	253
B	Description of the PROFINet Configuration File	257
C	References and Literature	262
D	Glossary	265

1 Welcome to Advanced PC Configuration

1.1 A New Concept for Your Benefit

Advanced PC Configuration is the new tool with which you can commission a PC station as part of an industrial communication network.

SIMATIC NET supports the option of using Advanced PC Configuration on a central engineering station to configure not only PC stations but also, for example, operator stations. The engineering station is a networked PC with the SIMATIC NCM PC program or STEP 7 installed.

Characteristics - Comparison with Previous Products

The new features of the SIMATIC NET software involve several changes to the previous configuration and project engineering procedures and these are summarized below:

- You can make all settings with **one** tool during project engineering and download them completely to the PC station.

The tool is SIMATIC NCM PC or STEP 7. Depending on your system configuration, you also use the Station Configuration Editor during the initial configuration.

The functions of these two tools are now so clearly delineated that you no longer need the aid of a further tool - the Commissioning Wizard.
- Properties that you previously configured using the "Set PG/PC Interface" program are now part of the project engineering and are downloaded to the PC station. These include, for example, the station address and the bus parameters. It is no longer necessary to create several databases.
- Properties that were previously specified in various project engineering programs are now configured in the project engineering in SIMATIC NCM PC / STEP 7. Examples of such project engineering tools include COML S7, COM PROFIBUS.
- Configuration parameters for the OPC Server that were previously stored in TXT files are now configured in the project engineering in SIMATIC NCM PC / STEP 7 and downloaded to the PC station.
- The OPC server can also handle communication on unconfigured S7 connections in PG operation. This function is, for example, required for use in HMI stations.

Supported Modules

You will find a list of modules supported and not supported by Advanced PC Configuration in the "hinw_e.rtf" file on the SIMATIC NET product CD (<CD drive> / sw / cdintern / hinw_e.rtf).

LDB Databases No Longer Required

By configuring on a central station and with the option of downloading, LDB databases are no longer required for the DP, FMS, and S7 protocols. Configuration and project engineering data can be exported to XDB files in STEP 7; they must be imported into the central data management on the PC station using the Station Configuration Editor.

Note

For more detailed information on the differences compared with the previous procedure and handling the software and modules, refer to Appendix A.

1.2 PC Stations in SIMATIC

Use of PCs in Automation

A "PC station" is a PC with communication modules and software components within an automation solution with SIMATIC.

The hardware configuration of a PC station can be compared with the configuration of an S7 controller In SIMATIC:

Virtual rack in the PC station

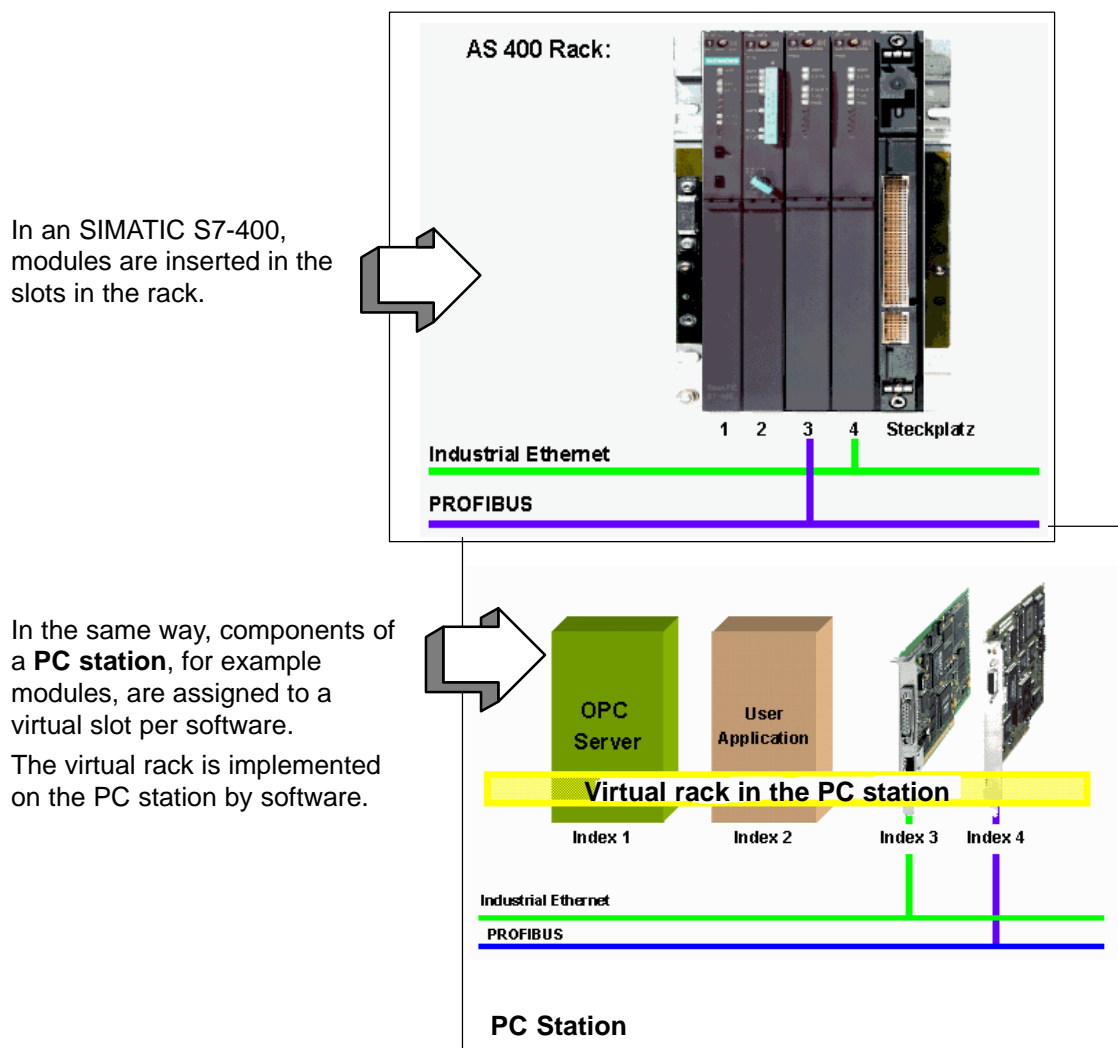

Software - The OPC Server as Central Component

A PC station contains SIMATIC NET communication modules and software applications. One typical software application with which user programs can communicate is the SIMATIC NET OPC server.

Uniform Engineering Environment

The PC station is handled just like a SIMATIC S7 controller during project engineering with STEP 7 / NCM PC: You connect the S7 stations and PC stations to the network in the network view and specify communication connections.

The project engineering data is downloaded to the stations at the touch of a button. With PC stations, you have two options:

- Download:
 - Direct transfer to the PC connected online.
- XDB Import
 - Project engineering data are saved in a file and can be imported into the PC station by any means of data transfer.

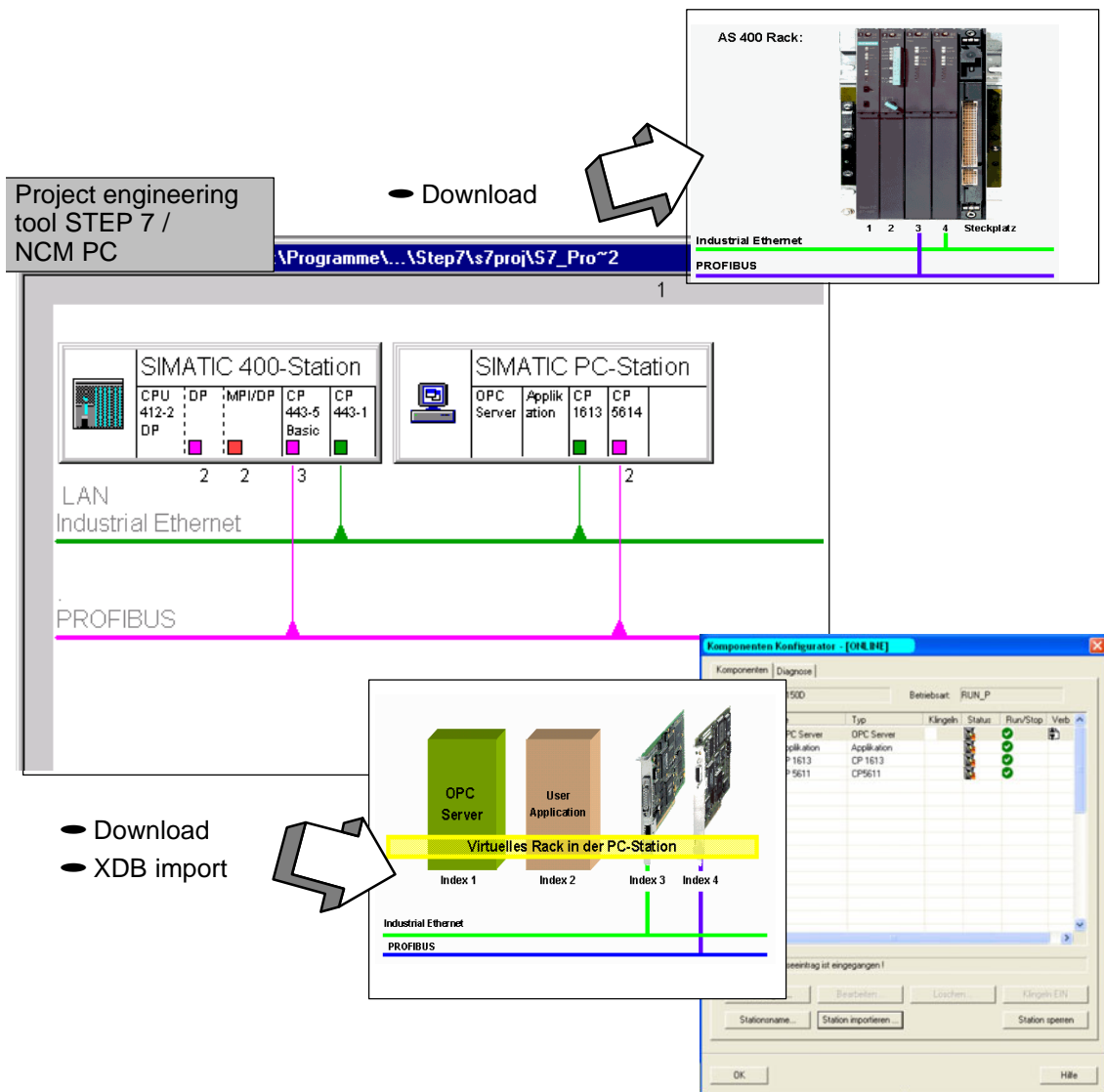

Index for Every Component

To allow communication between the components in the PC station and to receive project engineering data, each component is assigned a unique identification number. The identification number for modules, applications, and other components in a PC station is the index. Analogous to the slot of a module in an S7-400 controller, the index corresponds to a virtual slot in a PC station.

Note

Be careful not to confuse this “index” with a hardware slot, for example on the PCI bus of the computer. The slot on the PCI bus is not relevant for commissioning and is not used at any point.

1.3 A Brief Introduction to Tools and Utilities

Once you have installed the SIMATIC NET software, you have the following tools available:

Basic tools:



Station Configuration Editor

With this tool, you insert the modules and components into the “virtual” slots of the PC station and assign them addresses and parameters.



Project engineering tool SIMATIC NCM PC

SIMATIC NCM PC is a version of STEP 7 specially for project engineering of PC stations. It provides the full range of features of STEP 7 for PC stations.

Additional tools / utilities:



PC Station Wizard

The PC Station Wizard supports you when creating projects in SIMATIC NCM PC or STEP 7. It allows the automatic adoption of configuration on the local PC station. This helps you to make sure that your project engineering data is consistent.

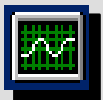

Symbol File Configurator

With the Symbol File Configurator, you can create symbol files that allow you the option of access to symbolic variables over the SIMATIC NET OPC server.



Configuration Console

The Configuration Console provides a variety of options for configuration and diagnostics of PC hardware components and PC user programs as well as the OPC server.



SIMATIC NET Information Service

The information service displays information on events that occurred due to activated trace requests. Trace requests can be made in the Configuration Console.



OPC Scout

With the OPC Scout, you can test an OPC application or commission the OPC server.



DCOM Settings (Windows system program)

To allow a client to use a COM object on another computer, the properties of the COM object must be configured on the client and on the remote computer.

1.4 Guide to Installation and Commissioning

Before you start commissioning, you should clarify the area of operation of your PC station and select the required mode for your communication module. The steps involved in commissioning differ depending on the mode you select for your communication module.

Below, you can see an overview of the steps involved in commissioning. The sections following then describe the individual steps and tools in greater detail.

1.4.1 PG Operation or Configured Mode - Considerations









When commissioning and operating a SIMATIC PC station, distinctions must be made between the following areas of application: Depending on the area of application, select the mode of the communication module.

- **PG Operation**

This is the default mode for a programming device (PG/PC) and HMI station.

- **Configured Mode**

This mode should be selected for productive communication between applications in the PC station and the programmable controllers, for example SIMATIC S7-400.

The primary use of your PC station is:		resulting area of application:		selectable mode :
<ul style="list-style-type: none"> • for diagnostics and maintenance and for programming and project engineering (STEP 7). 		programming device (PG/PC)		PG operation (default)
<ul style="list-style-type: none"> • for process control tasks (operator control and monitoring). It should be possible to use the station independent of a STEP 7 project. 		HMI station		
<ul style="list-style-type: none"> • for project engineering (STEP 7) in an automated plant operated with S7 stations • for tasks in process control and visualization. 		Engineering station (ES)		Configured mode
<ul style="list-style-type: none"> • as an automation system networked with programmable controllers. 		Runtime PC		

Mixed operation is possible.

Since you can set the mode for individual communication modules, you can also use the PC station in mixed operation.

Mixed operation, in this sense, means the use of several communications modules some in the configured and some in the PG mode.

Depending on the selected mode, the information below applies to the individual modules of the PC station.

Characteristics of the Selectable Modes





The table below shows the differences between the two selectable modes and how this affects handling of the PC station during commissioning and operation.

Table 1-1

Mode	Characteristics/Advantages when Commissioning and During Operation
PG operation (default mode)	<p>The module used in a PC station in this mode is not included in the STEP 7 project (it is, however, possible to take this module into account in the bus parameter calculation using the PG/PC station object).</p> <p>If your module in the PG or engineering station is configured for this mode, you must specify the interface on the PG or the engineering station explicitly with the "Set PG/PC Interface" or Configuration Console tool.</p> <p>With HMI stations, connections to communication partners are set up for process control over unspecified S7 connections that do not need to be configured in the project engineering.</p>
Configured mode	<p>The PC station along with the modules planned in the project engineering is included in a STEP 7 project so that the communication relations with the stations can be planned in the project.</p> <p>This has the following advantages:</p> <ul style="list-style-type: none"> ● Very simple commissioning (initial configuration) by using this configuration. ● Networking parameters stored in the project are adopted (PROFIBUS).

1.4.2 Commissioning for PG Operation - Overview

PG operation is the default mode for programming devices (PG/PC) and HMI stations.

Step	How ?	Tool
1. Installing SIMATIC NET software	Install with the SIMATIC NET CD	SIMATIC NET CD / Windows
2. Installing the hardware (PC modules)	Install the communication module in the PC station	
3. Configuration for PG operation	Assign addresses and interface parameters to the modules	Configuration Console Set PG/PC Interface
 		
Result: PC station ready for PG/PC operation		
Next step for HMI stations only:		
4. Configuration for HMI stations	Specify the access points for the applications	Configuration Console Set PG/PC Interface
 		
Result: HMI station and applications ready for operation Communication over unconfigured S7 connections is possible.		
5. Testing the configuration	Configuration Console	Configuration Console

1.4.3 Commissioning for Configured Mode - Overview

When commissioning in the configured mode, two situations can be distinguished. The situation depends on whether or not project engineering data is already available in the form of an XDB file or whether commissioning is independent of project engineering (no XDB file).

Initial configuration means the step in commissioning at which the module is switched to “configured mode” and obtains addresses and network parameters .

• Case a) Initial configuration with XDB file

With this method, it is assumed that the PC station and its components and applications is first created in project engineering in STEP 7 / NCM PC. This produces a database (XDB file) that is then available for the commissioning engineer for the initial configuration.

The advantage of this is that the project engineering data and the PC configuration are consistent and the total effort is minimal.

Step	How ?	Tool
Project engineering (as prerequisite for initial configuration)	Steps in project engineering of the PC station: <ul style="list-style-type: none"> • Create the PC station in NCM PC • Enter modules and applications • Create connections in NetPro • Use symbols (in the project engineering of the OPC server) • Save the project engineering data of the PC station in XDB. 	NCM PC / STEP 7 <ul style="list-style-type: none"> • SIMATIC Manager • HW Config • NetPro • HW Config • SIMATIC Manager
1. Installing SIMATIC NET software	Install the SIMATIC NET software based on the installation instructions	SIMATIC NET CD / Windows
2. Installing the hardware (PC modules)	Install the communication module in the PC station	Refer to the documentation on the CP
3. Initial configuration	Import XDB Project engineering data is transferred to the PC station.	Station Configuration Editor (later download of project engineering data also possible with NCM PC / STEP 7)
 <p>Result: PC station is ready for productive communication</p>		
4. Testing the configuration	Configuration Console	Configuration Console

• Case b) Initial configuration without XDB file

This is, for example, the situation when the commissioning personnel do not have an XDB file, but the devices need to be installed in a plant and their functionality checked.

Regardless of the initial configuration, the stations and their connections can be (PC and PLC) can be set up in the project engineering. The project engineering data is then transferred to the previously configured PC stations in the system. Depending on whether they can be reached, this is done by downloading or by importing an XDB file.

To ensure that the configuration on the PC station and the project engineering are consistent, it is advisable to import the configuration data from the PC station.

Step	How ?	Tool
1. Installing SIMATIC NET software	Install the SIMATIC NET software based on the installation instructions	SIMATIC NET CD / Windows
2. Installing the hardware (PC modules)	Install the communication module in the PC station	Refer to the documentation on the CP
3. Initial configuration	Module configuration	Station Configuration Editor
 <p>Result: The PC station with its modules and applications is configured and ready to receive project engineering data</p>		
4. Testing the configuration	Configuration Console	Configuration Console
5. optional: Data export	Enter the configuration in a new (temporary) STEP 7 project "PC station".	PC Station Wizard / NCM PC
6. Project engineering (this is not dependent on the previous steps that is necessary for step 7.)	Steps in project engineering of the PC station: <ul style="list-style-type: none"> • Create the PC station in NCM PC • optional (see Step 5): Adopting the configuration from the project created in Step 5. • Enter modules in applications (identical to changes in the Station Configuration Editor) • Create connections in NetPro • Use symbols (in the project engineering of the OPC server) • for "offline mode": Save project engineering data of the PC station in XDB. 	NCM PC / STEP 7 <ul style="list-style-type: none"> • PC Station Wizard (local only) / SIMATIC Manager • HW Config • NetPro • HW Config / NetPro

Step	How ?	Tool
7. Downloading the Project Engineering Data to the PC Station	Depending on how the PC station can be reached: <ul style="list-style-type: none"> ● online: (local or remote) load project engineering data on station ● Import XDB 	<ul style="list-style-type: none"> ● SIMATIC Manager ● Station Configuration Editor
<div style="display: flex; align-items: center; justify-content: center;"> <div style="text-align: center; margin-right: 20px;">  </div> <div> <p>Result: PC station is ready for productive communication</p> </div> </div>		
8. Testing the configuration	Configuration Console	Configuration Console

□

2 Getting Started “Configured Mode”

The “configured mode” should be selected for productive communication between applications in the PC station and the programmable controllers, for example SIMATIC S7-400.

This chapter explains how to commission your PC station with communication modules for this mode for the first time (initial configuration).

In conjunction with the project engineering, we will explain how to handle the data exchange between the PC station and the project engineering tool.

Requirement: SIMATIC NET PC software and hardware are installed

Before you work through the steps described here, you must first install the SIMATIC NET software and the hardware on your PC station.

- **Installing SIMATIC NET PC Software**

Follow the procedure described in the Installation Instructions that accompany every SIMATIC NET PC module to install the products of the SIMATIC NET PC Software CD.

The installed products are described in detail in the “Tools” section.

- **Installing hardware (PC modules)**

Install the hardware in your computer as described in the Installation Instructions that accompany every module.

2.1 Steps for Initial Configuration



For the initial configuration, you use the Station Configuration Editor tool.

Why do we need an initial configuration?

When a module is started up for the first time, it must be configured. This initial configuration is necessary for all newly installed modules.

After the initial configuration of the modules, the PC station is prepared to receive project engineering data. This step is comparable with inserting components in the rack of an S7-400 station.

Result

When you start the PC station, the PC module of the PC station is initially in the PG operation mode.

By adding the communication module in the Station Configuration Editor, the module is automatically switched to the "configured mode" and the index (the "virtual slot number") of the module is set.

To make the PC station accessible over the network, you can specify a station address and bus parameters during the initial configuration.

Interaction between Initial Configuration and Project Engineering

Depending on the area of application, two situations must be distinguished:

- Case a) Initial configuration with XDB file
- Case b) Initial configuration without XDB file

2.1.1 Case a) Initial Configuration with XDB File

In this case, you can import the XDB file with the project engineering data for the PC station directly.

The advantage of this is that the project engineering data and the PC configuration are consistent and the total effort is minimal. Address parameters are adopted from the project engineering.

Follow the steps below:

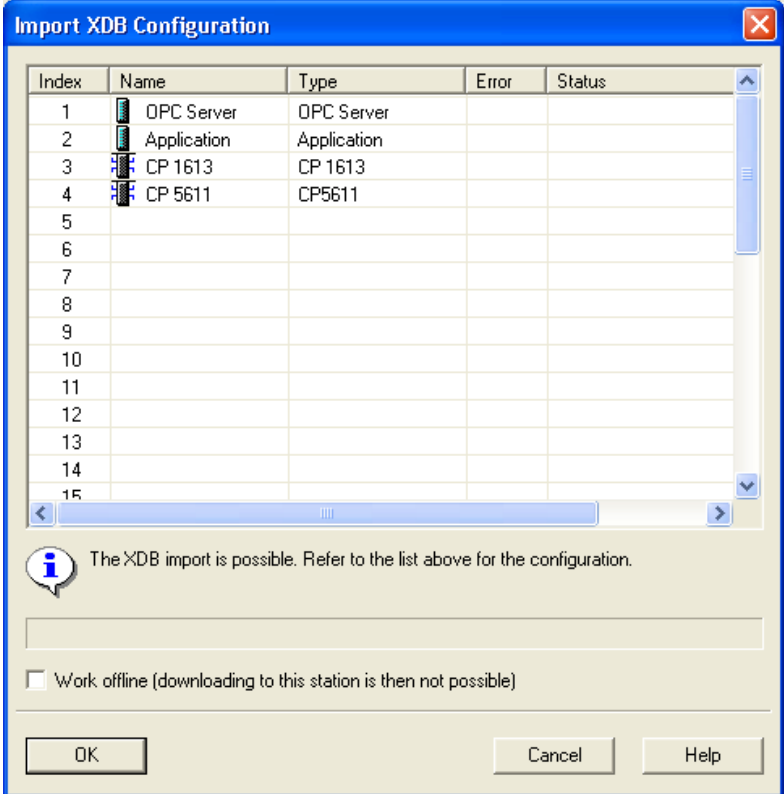
How to Make the Initial Configuration with an XDB File	
1	<p>Start the Station Configuration Editor from the Start menu. (Start ► Station Configuration Editor) or by double-clicking on the icon in the Windows Systray. You first see an empty configuration list.</p>
2	<p>Import the XDB file using the "Import Station..." button. All the modules and applications specified in the project engineering are entered and displayed in a window. During import, all the project engineering data; in other words, station name, modules, applications, communication connections, and symbols are entered in the PC station. Importing is possible only when the imported configuration matches the existing local configuration.</p> 

How to Make the Initial Configuration with an XDB File	
3a	If you want to prevent project engineering data from being transferred online at a later point in time, select the "Work offline..." option. As default, project engineering data can be transferred online.
<div style="display: flex; align-items: center;"><div style="text-align: center; margin-right: 20px;"></div><div><p>Result:</p><p>PC station is ready for productive communication</p><ul style="list-style-type: none">● Module addresses are set;● Communication connections configured in the project engineering are established;● Variables can be accessed using symbols configured in the project engineering.</div></div>	



Tip:

You can also follow this procedure in the example "OPC Configuration for Industrial Ethernet" in this manual; see Section 6.

Where do we go from here?

You can now use the other tools from SIMATIC NET for diagnostics, commissioning, and testing.

See also Section 1.3.

2.1.2 Initial configuration without XDB file

In this case, you specify the modules during initial configuration in the Station Configuration Editor.

You can transfer project engineering data to the PC station later by downloading or importing an XDB file.

You can also create project engineering data locally on the PC station and then import it later into the engineering system (NCM PC). This makes it extremely simple to create a configuration in the project engineering system that matches the configuration on the real PC station.

Follow the steps below:

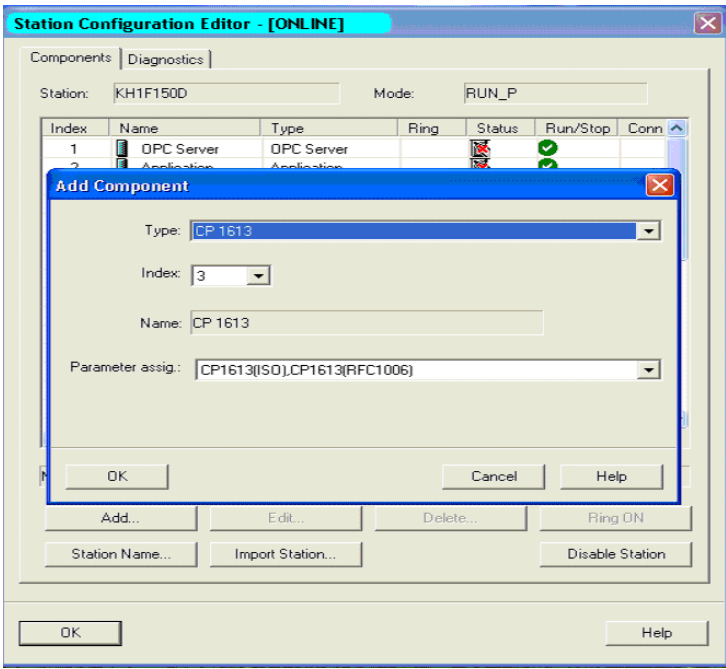
How to Make the Initial Configuration without an XDB File	
1	<p>Start the Station Configuration Editor from the Start menu. (Start ▶ Station Configuration Editor) or by double-clicking on the icon in the Windows Systray.</p> <p>You first see an empty configuration list.</p>
2	<p>Assign the station name using the “Station Name...” button.</p>
3	<p>In the next step, you enter the components.</p> <p>Using the “Add...” button, select the module that will be put into “configured mode”. All the modules installed in the local station are not yet configured are displayed for selection.</p> <p>Caution: If there are several Softnet PROFIBUS modules, only one can be configured in project engineering.</p> 

How to Make the Initial Configuration without an XDB File	
4	In the properties dialog that opens, give the module an address. In some cases, you can also set further module parameters, for example bus parameters, (mandatory with PROFIBUS).
5	Repeat the steps for all other modules that exist in the local station and that you want to operate in configured mode.
6	Using the "Add" button, add the applications to be operated on the station.
7	Repeat the steps for all other applications you want to use for the configured mode.
<div style="text-align: center;"></div> <p>Result: PC station is configured with modules and applications and ready to receive project engineering data (select online mode)</p>	



Tip:

You will also find this procedure in our example "OPC Configuration for PROFIBUS"; see Section 7.

Where do we go from here?

In the next step, you supply the PC station with project engineering data.

2.2 Steps in Creating Project Engineering Data



To create the project engineering data, you use the SIMATIC NCM PC or SIMATIC STEP 7 tool.

Why do we need project engineering data?

To allow the device networked in a plant to communicate, the devices must be supplied with data on the components and the communication connections. Before devices can go over to productive operation, the project engineering data must first be created and loaded on the devices.

This project engineering includes not only the PLC such as SIMATIC S7 stations but also the PC stations so that the communication relations between all devices of the plant can be specified. This makes a consistency check and synchronization of the elements of the system possible.

Apart from specifying the PLC and PC stations and their properties on the LAN, project engineering also includes defining communication connections and symbols for process variables on the OPC server.

Result

Once the project engineering data have been downloaded to or imported into the PC station, the applications can communicate over the established communication networks with the stations accessible over the network.

Initial Situation

As already explained in the previous section "Steps to Initial Configuration", two different situations must be distinguished:

- Case a) An XDB file for initial configuration is available

To be able to make the initial configuration in the next step, you must first create the project engineering data for the PC station with NCM PC / STEP 7 and then make this data available in an XDB file.

- Case b) The initial configuration has already been made on the PC station

Project engineering data is downloaded or imported as an XDB file following initial configuration.

Follow the steps below:

Steps in Project Engineering	
1.	<p>Start the SIMATIC NCM PC from the Start menu. (Start ► SIMATIC ► SIMATIC NCM PC).</p> <p>As an alternative if "online local" : Use the PC Station Wizard</p> <p>If you want to create the project engineering database on the PC station you are configuring (online local) and the initial configuration has been made, you can start the PC Station Wizard as an alternative.</p> <p>This gives you the option of adopting the configuration data created previously in the Station Configuration Editor in a new or existing STEP 7 project.</p> <p>Since we are assuming that we are commissioning the station for the first time, you can select the following options provided by the PC Station Wizard:</p> <ul style="list-style-type: none"> ● Editing a saved project engineering configuration Open an existing project and compare the local configuration with the information in the project. This adds the current PC station to a project in which, for example, project engineering data for S7 stations already exists. ● Creating a new project engineering configuration Create a new project and transfer the local configuration to the project. <p>Tip: You can also select this option when you want to backup the project engineering data in an archive. This archive file can be used on an engineering system in STEP 7.</p>
2.	<p>Create a PC station in an existing or new project.</p> <p>Note: This is omitted when the data is entered by the PC Station Wizard or when an archived configuration is used (see above).</p>



Steps in Project Engineering

3. Change to NCM PC Config / HW Config and enter the intended modules and applications (take them from the catalog).
(omitted if data entered by the PC Station Wizard)

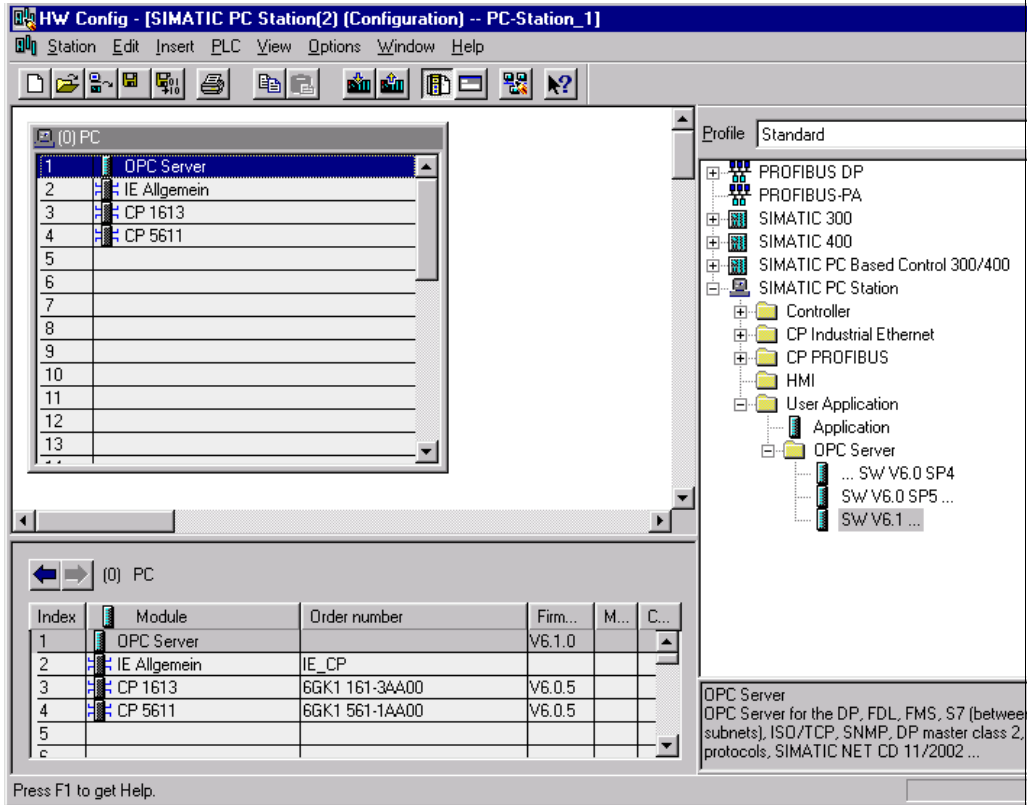

The software applications that use communication services directly must also be specified in project engineering. One direct use is calling the protocol-specific function libraries. The OPC server uses communication services directly and must be included in project engineering. OPC clients only require indirect access via the OPC server and do not need to be configured in project engineering.

4. Optional:
- If symbol tables were created for S7 stations in your project, you can make them accessible to the OPC server.
- When you later import the XDB file or download the project engineering data to the PC station, these symbol tables are included.
- Open the properties dialog of the OPC server to make your selection:

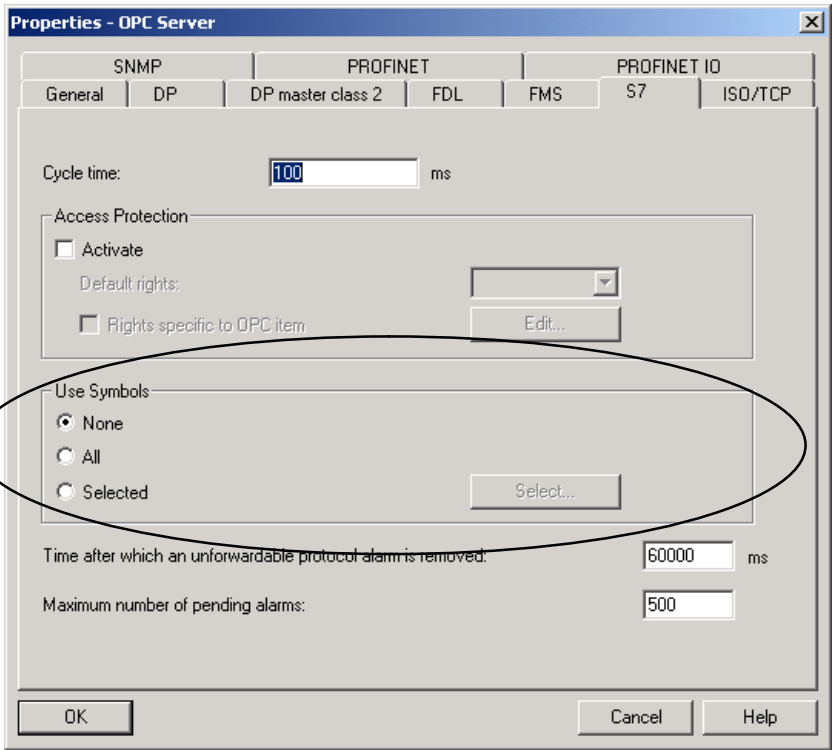
Steps in Project Engineering	
	
5.	Save the configuration. (omitted if data entered by the PC Station Wizard)
6.	Change to NetPro to network the station and to create the connections in the project engineering.

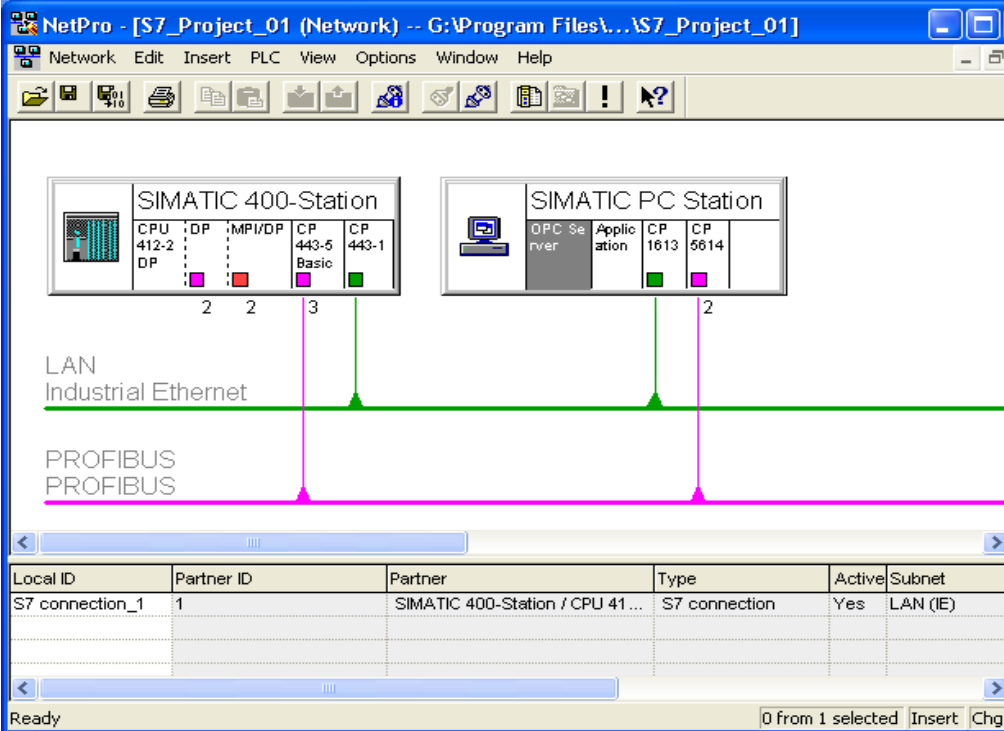
Steps in Project Engineering													
	 <table border="1" data-bbox="347 857 1356 969"> <thead> <tr> <th>Local ID</th> <th>Partner ID</th> <th>Partner</th> <th>Type</th> <th>Active</th> <th>Subnet</th> </tr> </thead> <tbody> <tr> <td>S7 connection_1</td> <td>1</td> <td>SIMATIC 400-Station / CPU 41...</td> <td>S7 connection</td> <td>Yes</td> <td>LAN (IE)</td> </tr> </tbody> </table> <p>Ready 0 from 1 selected Insert Chg</p>	Local ID	Partner ID	Partner	Type	Active	Subnet	S7 connection_1	1	SIMATIC 400-Station / CPU 41...	S7 connection	Yes	LAN (IE)
Local ID	Partner ID	Partner	Type	Active	Subnet								
S7 connection_1	1	SIMATIC 400-Station / CPU 41...	S7 connection	Yes	LAN (IE)								
7.	<p>XDB export for offline mode:</p> <p>When you save and compile the project, the project engineering data of the PC station is saved in an XDB file.</p> <p>You will find information on the storage location of the XDB file in the "Configuration" tab in the Properties PC Station dialog.</p>												

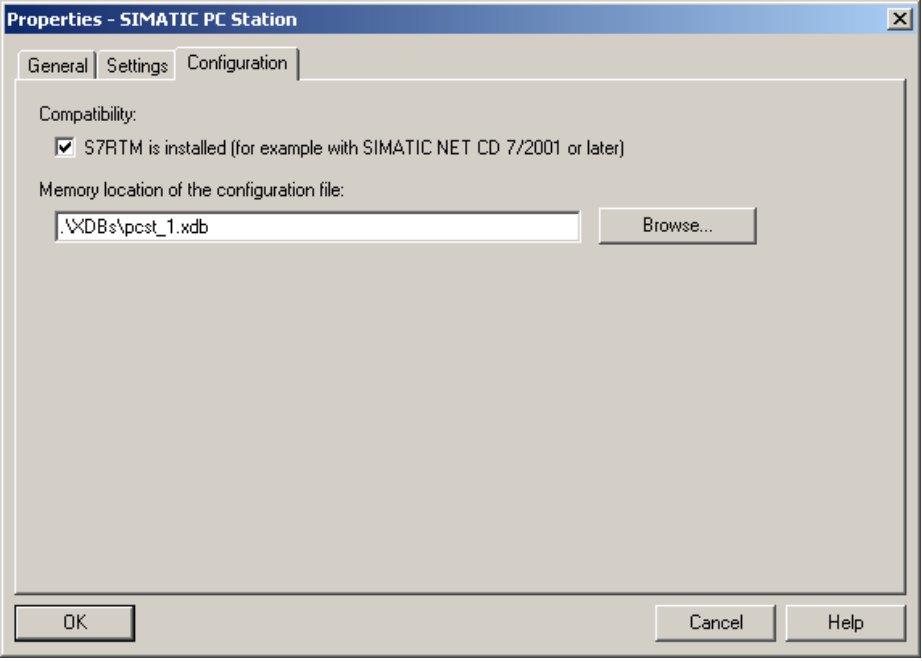
Steps in Project Engineering	
	
8.	<p>If the PC station can be reached online (local or remote), you can download the project engineering data directly to the PC station.</p> <p>Note: To load the project engineering data locally, you must set the access point S7ONLINE for the PC station to PC-internal.</p>

Summary

In the “project engineering” step described here, the following activities were explained:

1. Creating a STEP 7 project or using an existing STEP 7 project.
2. Creating a PC station in the STEP 7 project (NetPro / HW Config).
3. Inserting and networking PC modules in the PC station (HW Config/NetPro).
4. Creating applications (here the OPC server).
5. Creating the engineering data for connections between the applications.
6. Storing the project engineering data in an XDB database.

For offline mode, the XDB database is then available and can be used to import the engineering data on the PC station.

Where to go from here - optional activities

Once the project engineering configuration has been accepted, the PC station is operational. The following steps allowing the use of symbols, diagnostics, and calling the OPC Scout are optional. You should, however, check that the modules in your PC station are operational using the diagnostic functions.

3 Getting Started "PG Operation"

This chapter shows you how you can configure your PC module in PG operation. In this situation, we distinguish two modes:

- Programming device (PG/PC)
- HMI stations

The default setting for the PC modules is PG operation.

Requirement: SIMATIC NET PC software and hardware are installed

Before you work through the steps described here, you must first install the SIMATIC NET software and the hardware on your PC station.

- Installing SIMATIC NET PC software

Follow the procedure described in the Installation Instructions that accompany every SIMATIC NET PC module to install the products of the SIMATIC NET PC Software CD.

- Installing hardware (PC modules)

Install the hardware in your computer as described in the Installation Instructions that accompany every module.

3.1 Configuration for PG Operation - Programming Device (PG/PC)

You configure a module using the "Set PG/PC Interface" tool.

Follow the steps below:

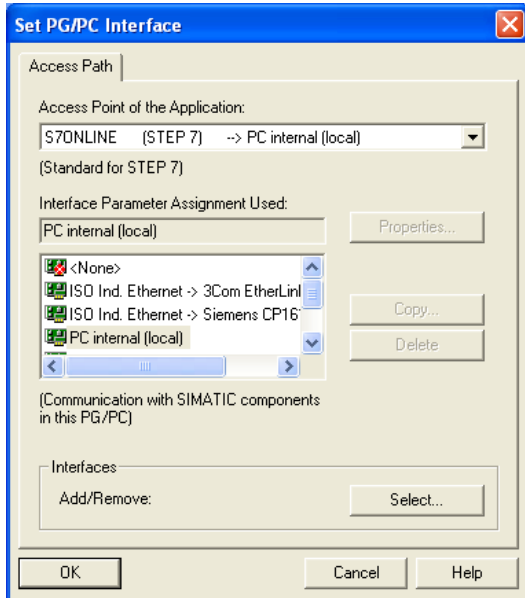
How to Configure for PG Operation	
1.	<p>You can start the configuration program from the Windows taskbar: Start ▶ SIMATIC ▶ SIMATIC NET ▶ Settings ▶ Set PG/PC Interface. As an alternative you can also start it from the Control Panel: Start ▶ Settings ▶ Control Panel ▶ Set PG/PC Interface.</p>
2.	Assign the access point for your application to the module.
2.1	<p>To make your module usable for STEP 7, follow the steps outlined below in the "Set PG/PC Interface" configuration program:</p> <p>Select the access point "S7ONLINE" in the "Access Point of the Application" list box. The current assignment then appears at the bottom in the list box "Interface Parameter Assignment Used".</p> 
2.2	<p>Select the required entry in the "Interface Parameter Assignment Used" list box. Some modules offer alternatives, for example the CP 1613 as follows:</p> <ul style="list-style-type: none"> ● If you use the TCP protocol - "CP1613(RFC1006)", ● If you use the ISO protocol - "CP1613(ISO)", and CP5612 or CP5614 as follows: ● Normal situation - "CP5613_5614(PROFIBUS)", ● on an MPI chain - "CP5613_5614(MPI)". <p>For further details on setting access points, refer to...</p>

How to Configure for PG Operation	
3.	<p>Set the required communication parameters.</p> <p>With your module selected, you can click on "Properties" and then set the communication parameters. In normal situations, the parameter settings do not need to be modified (for more detailed information on the parameters, refer to the online help that you can display by clicking the "Help" button in the Settings dialog).</p> <p>For more information on certain module types, see below.</p>
4.	<p>When you close the Properties window, you return to the start dialog of the "Set PG/PC Interface" communication program.</p>
5.	<p>Close the configuration program with the "OK" button.</p> <p>The module is now set up for PG operation.</p>

Note

Remember that by clicking on a module to make settings, it is possible to change the assignment. If you have accidentally changed an assignment, make sure you correct it again.

Setting Communication Parameters - Extra Information

Prior to operation, the following communications parameters must be set:

- For PROFIBUS modules (for example CP 5613, CP 5511, CP 5611, CP 5512):
 - Programming device / PC is the only master on the bus
 - Address
 - Transmission rate
 - Profile (depending on the application: DP for the DP protocol, otherwise the fast setting "Standard" or the safe setting "Universal")
- For CP 1613 TCP:
 - The IP address, subnet mask, and gateway address in the "Ethernet (MAC) and IP Addresses" tab
- For SOFTNET TCP (for example CP 1512, CP 1612):
 - The IP address, subnet mask and gateway address must be set. You can do this directly in the Windows Control Panel in "Network" or here using the "Network Properties" button in the "TCP/IP Network" tab.

For CP1613 ISO and SoftNet ISO, it is not normally necessary to make any communication parameter settings.

Please note that you can also use diagnostic functions by clicking the "Diagnostics" button in the start dialog of "Set PG/PC Interface".

3.2 Configuration for PG Operation - HMI Stations

You configure a module using the "Set PG/PC Interface" tool.

Initially the procedure is identical to configuration for PG operation - programming device (PG/PC) as described in Section 3.1.

The communication module remains in "PG operation"; it is then configured so that applications can communicate over communication interfaces without further connection configuration in the project engineering.

The applications access the communication module using access points. If new access points need to be entered, this can also be done with the "Set PG/PC Interface" or "Configuration Console" tools.

Finally, you use the OPC Scout to assign the required items and connection parameters to the user program.

Setting Access Points - Follow the steps below:

How to Configure for HMI Operation	
1.	<p>You start in the same way as described for commissioning for PG operation in the previous section:</p> <p>You can start the configuration program from the Windows taskbar: Start ▶ SIMATIC ▶ SIMATIC NET ▶ Settings ▶ Set PG/PC Interface.</p> <p>As an alternative you can also start it from the Control Panel: Start ▶ Settings ▶ Control Panel ▶ Set PG/PC Interface.</p>
2.	<p>Assign the access point for your application to the module.</p> <p>Note: You can generally also select the "S7ONLINE" access point here.</p>

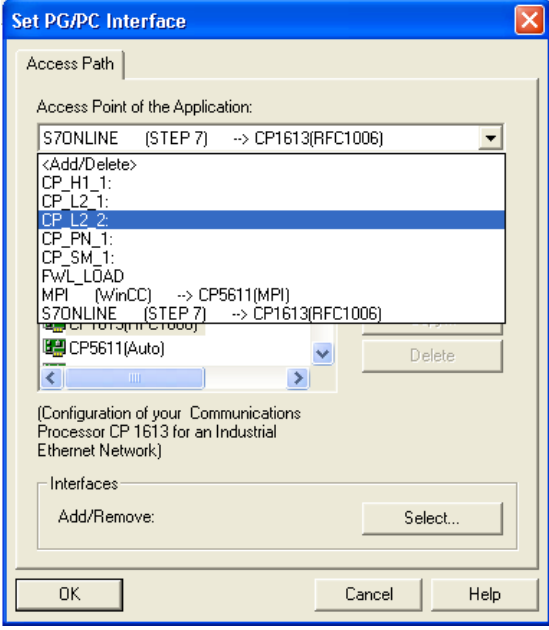
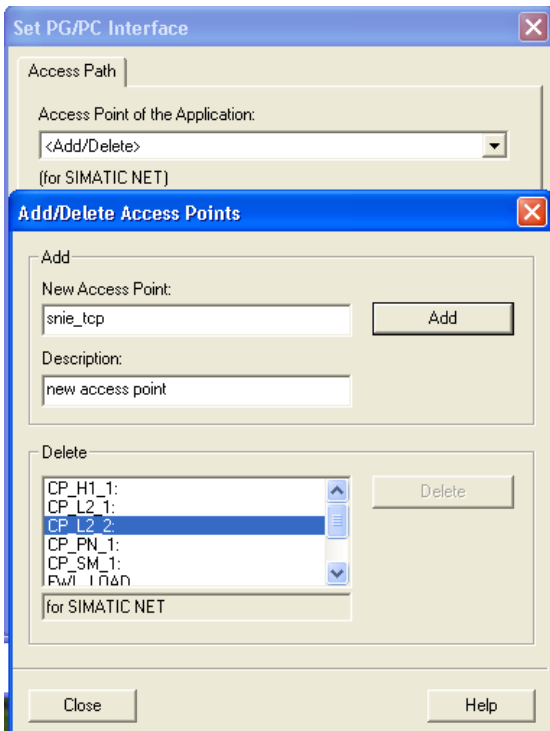
How to Configure for HMI Operation	
2.1	<p>Select the access point in the "Access Point of the Application" list box. The current assignment then appears at the bottom in the list box "Interface Parameter Assignment Used".</p> 
2.2	<p>If the suitable access point for your application is not present, click the "Select" button in the "Add/Remove" field. This opens the dialog in which you can add new access points. Example:</p> 

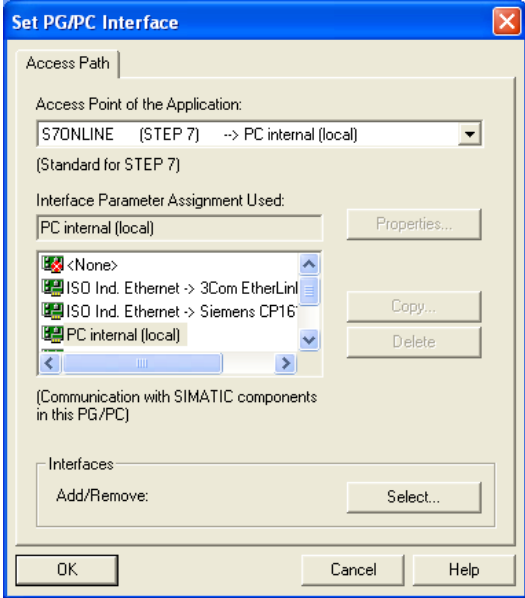
How to Configure for HMI Operation	
2.3	<p>Confirm your entries.</p> <div style="text-align: center;">  </div> <p>As an alternative, you can also specify new access points in the "Configuration Console" tool. -> see "Tools"</p>
2.4	<p>In the "Interface Parameter Assignment Used" list box (or "Assigned Interface Parameter Assignment"), select the entry you require. Some modules offer alternatives, for example the CP 1613 as follows:</p> <ul style="list-style-type: none"> ● If you use the TCP protocol - "CP1613(RFC1006)", ● If you use the ISO protocol - "CP1613(ISO)", and CP5612 or CP5614 as follows: ● Normal situation - "CP5613_5614(PROFIBUS)", ● on an MPI chain - "CP5613_5614(MPI)". <p>For further details on setting access points, refer to...</p>
3.	<p>Set the required communication parameters.</p> <p>For more detailed information on the module-dependent settings, refer to the previous section "Step: Configuration for PG operation - programming device (PG/PC)".</p>
4.	<p>When you close the Properties window, you return to the start dialog of the "Set PG/PC Interface" communication program.</p>
5.	<p>Close the configuration program with the "OK" button.</p>

Note

Remember that by clicking on a module to make settings, it is possible to change the assignment. If you have accidentally changed an assignment, make sure you correct it again.

Entries in the Client Program

For communication without project engineering data as described here, all the data of the partner device relevant for communication must be known. Apart from the access point described above, this includes the connection name and the station address. The necessary parameters are described in detail in the manual on OPC /1/.

Below, we want to show you how to add the ITEM and its parameters to the user program.

Adding items - Follow the steps below:

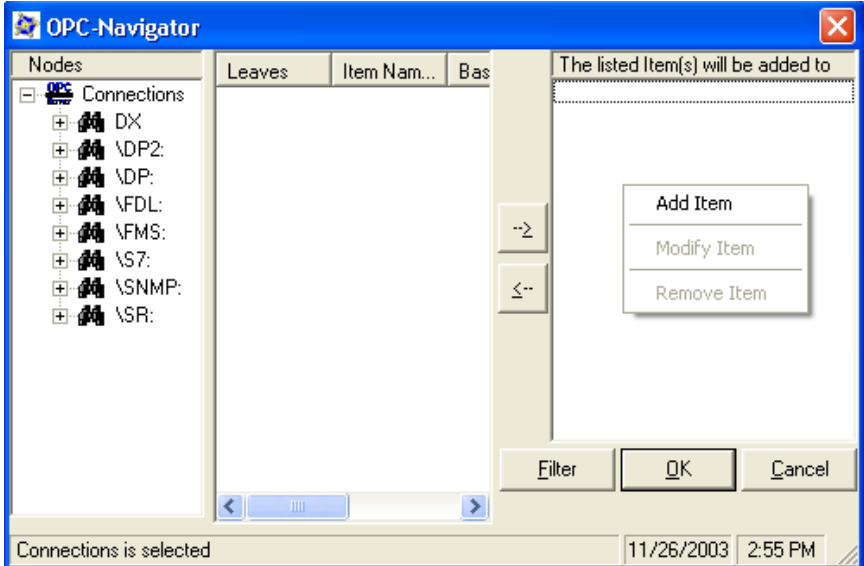
How to Configure for HMI Operation	
1.	<p>Open the client program and create an item using the syntax shown above. In the OPC Scout program, open the input boxes for inserting items by selecting "Add Item" in the context menu on the right-hand side of the program window. Browsing for the unconfigured connection is not yet possible at this time.</p> 

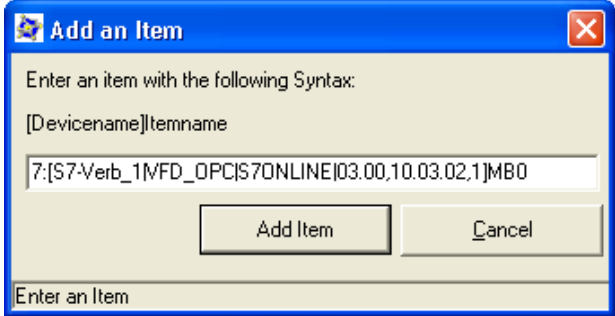
How to Configure for HMI Operation	
2.	<p>Add item</p> <p>Enter the item with the previously described parameters in the "Add Item" dialog and click on the "Add Item" button. If the syntax is correct, the item appears in the name space under the "S7" branch.</p>
3.	

After adding the item and as long as the item is active, the connection can be used like a configured connection. This means that you can browse in the name space and also add further items without using the syntax of the unconfigured connection. All you need to do is specify the connection name, for example S7:[S7_conn_1]MB1.

4 Using Additional Functions - Special Features to Note

4.1 Checking the Configuration and Diagnostics

The “Configuration Console” tool is a central tool for access to the components and data of the PC station during the following tasks:

- Commissioning and operation
- Editing the configuration
- Diagnostics

For more detailed information on the available functions, refer to the description in Chapter 15 “Tools”.

4.2 Testing with the OPC Scout

If you use the OPC interface; in other words, you have used the OPC Server in the project engineering configuration, you can check the functionality of your communications system as the last step. With the OPC Scout, you have access to all process variables accessible with the configured protocols and connections via the OPC Server.

Using the OPC Scout, you can monitor the values of process variables, read values explicitly, and write values. The OPC Scout displays the name space of the variables consisting of configured communications connections and symbolic names.

For more detailed information on the available functions, refer to the description in Chapter 16 “Tools”.

4.2.1 Detecting Errors in Communication with the OPC Scout

Introduction

The OPC Scout shows you the status of the communication connections. This can be done using the properties of process variables or using information variables. You can then recognize when a partner device is not accessible.

Errors when Connecting with the OPC Server

- The locally installed OPC Server cannot be started.

Possible causes for this are as follows:

- The PC station is currently receiving a new configuration.
- By installing and OPC Server of another manufacturer that has not kept to the guidelines laid down by the OPC Foundation common files have been corrupted.

- The remote OPC Server is not accessible.

This can occur when using DCOM and can have various causes:

- The network connection is down.
- The DCOM configuration of the local and remote server is not correct.
- The remote server is not correctly installed or configured.

Errors when Adding Variables

- Variable cannot be added

Adding some or all variables is denied in the Navigator of the OPC Scout.

Possible causes for this are as follows:

- The variable name entered does not have the correct syntax.
- When using symbolic variables: The symbol file does not match the project engineering configuration.
- The access permissions for the variables are restricted: Neither read nor write permissions.

- A protocol or connections are not visible

No protocols are visible in the left-hand window of the navigator or protocols or connections are missing. Possible causes for this are as follows:

- Some of the required connections were not created during configuration in the project engineering.
- A module configured in the project engineering does not exist or was not correctly initialized.
- The configuration data created in the project engineering configuration have not yet been transferred or transfer was unsuccessful.

Checking the status of process variables

- Quality of the variables is “bad”.

In the table view of the process variables, the value “bad” is entered for some or all variables in the “Quality” column. Possible reasons for this are as follows:

- The network connection to the partner device is down.
- The partner device is not configured in the project engineering.
- The bus parameters of the PC station and partner device do not match.

- The value of the information variable for the connections status is “Down”.

The information variable has the quality “good”, however, the value is not “Up”.

These variables are generated by the OPC Server and always have the quality “good”. The possible reasons for the value on the variable identical to those for quality = “bad”.

4.3 Further Functions / Special Features

4.3.1 Adopting the Project Engineering and Symbols from PROFINet iMap and SIMOTION Scout

You can also use the symbols from PROFINet iMap and SIMOTION Scout with the OPC Server. These symbol files include not only the symbols but other project engineering information so that additional connection configuration for the PC station is not necessary.

Follow the steps below:

Call the relevant export functions for SIMATIC NET OPC symbol files in the engineering programs PROFINet iMap or SIMOTION Scout. Follow the instructions in the corresponding documentation.

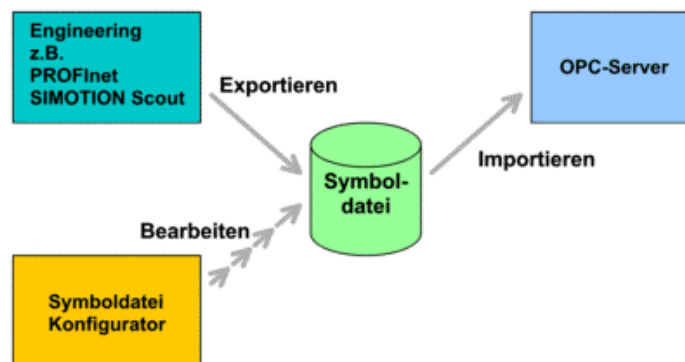

Transfer the created symbol file to your PC station. You can specify the required symbol file in the "Configuration Console".

To use the symbols for PROFINet iMap and SIMOTION Scout, you must also select the PC module and with it the subnet via which the PROFINet or SIMOTION partner stations are connected. You make this setting in an extra dialog when selecting the symbol file in the "Configuration Console".

You can check the selected module with the "Configuration Console" program using the "Access points" function:

- fixed access point SIMOTION CP_SM_1: e.g. CP_SM_1: -> CP5613(PROFIBUS)
- fixed access point PROFINet CP_PN_1: e.g. CP_PN_1: -> CP1613(RFC1006)

For further information on PROFINet and SIMOTION, please refer to the documentation of the PROFINet iMap or SIMOTION Scout engineering programs.

4.3.2 Configuring Access Points for STEP 7 and STEP 5

How Access Points are used

Many user programs require an "access point" to be specified to allow an assignment to the communication module.

The access point is a symbolic name with which the user program can access the assigned communication interface / module.

Applications that handle communication over connections configured in the project engineering do not require the access points described here.

For example, for local PG operation, STEP 7 works with the access point "S7ONLINE", and STEP 5 uses the access point "CP_H1_1:" for Industrial Ethernet and the access point "CP_L2_1:" for PROFIBUS.

By reconfiguring an access point, you can for example, control the interface over which STEP 7 communicates.

Tools

In the description of the steps "Configuration for PG operation - programming device (PG/PC) / HMI stations", we showed you how to specify and assign access points using the Set PG/PC Interface tool.

The following section describes how you can manage access points with the "Configuration Console" tool (see also "Tools").

Viewing and Setting Access Points

Follow the steps outlined below to display the existing access points (Steps 1 and 2) and to create a new access point (Steps 3 and 4):

Step	Description
1	Start the "Configuration Console" program (taskbar Start ▶ Simatic ▶ SIMATIC NET ▶ Settings ▶ Configuration Console).
2	In the navigation area, go to the branch SIMATIC NET Configuration Access Points.
3	After right-clicking on the branch end "Access Points", select the menu New ▶ New Access Point ▶ "New Access Point" dialog.
4	Enter the name of the new access point.

Changing an Access Point

The access point is assigned to the network card using the "Configuration Console" program.

Follow the steps outlined below to assign an access point to a network card.

Step	Description
1	Start the "Configuration Console" program (taskbar Start ▶ Simatic ▶ SIMATIC NET ▶ Settings ▶ Configuration Console).
2	In the navigation area, select the "Access Points" branch under SIMATIC NET Configuration.
3	Double-click on the required access point in the right-hand list box, for example, "S7ONLINE". Reaction: The "Properties of S7ONLINE" dialog box opens.
4	Select the interface over which you want to communicate in the "Associated interface parameter assignment" list box and click "OK".

4.3.3 Points to Note with SOFTNET Industrial Ethernet Modules

Introduction

Modules operated with the "SOFTNET Industrial Ethernet" software product are integrated in Windows just like a standard network adapter supplemented by additional protocols. The station parameters for such modules can only be set with the standard mechanisms of Windows.

Parameters

The parameters to be set with Windows mechanisms are as follows:

- IP address
- Subnet mask
- Gateway address

Even when changing the station parameters during the initial configuration, the Windows configuration program must be used. During the initial configuration, you are prompted to start this tool.

Transferring the Project Engineering Data

Note

Make sure that the network parameters of the PC station match the information entered in the configuration in your project. If this is not the case, it is not possible to establish connections.

When a configuration is transferred from the project engineering system to a PC station and the transferred configuration contains different network parameters from those configured locally on the PC station, a warning is displayed. In this case, you must adapt the project engineering configuration in your project or set the local parameters according to the project engineering configuration.

5 Project Engineering for the OPC Server

OPC Server

With the SIMATIC NET OPC Server described here, SIMATIC NET offers you a convenient tool with which your PC applications can write and read process data and receive notification of process events.

By creating a project engineering database, you can specify the behavior of the OPC Server. You then download the project engineering data to the PC station with NCM PC.

This chapter describes the options available to you when creating the project engineering data for the OPC server with the NCM PC project engineering tool.

- Using Default Settings or Project Engineering Parameters

The parameters you can set with NCM PC all have default settings so that in most cases problem-free communication is possible.

This chapter is only relevant for you if you want to change settings.

Where to Find Further Information

- Using the interface to the OPC Server in PC applications:

How you address the OPC Server in your PC application and how the PC application reacts to the behavior of the OPC Server is not described in this documentation.

For more information on this topic, please read the detailed OPC documentation provided by SIMATIC NET /1/. You will find information on the basic aspects of the OPC indicated by the graphic shown below:

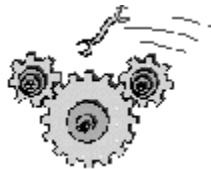

Grundlagen der OPC-Schnittstelle

5.1 Significance of Project Engineering

The OPC Server Application Type

The OPC Server can be configured as an interface to all available communication protocols. You can create this object only once in a PC station.

You can then use this OPC Server for communication from user programs (OPC clients).

What Can be Configured in the Project Engineering Database?

You can configure the following:

- Protocol and service-dependent properties
- Properties for specific connections

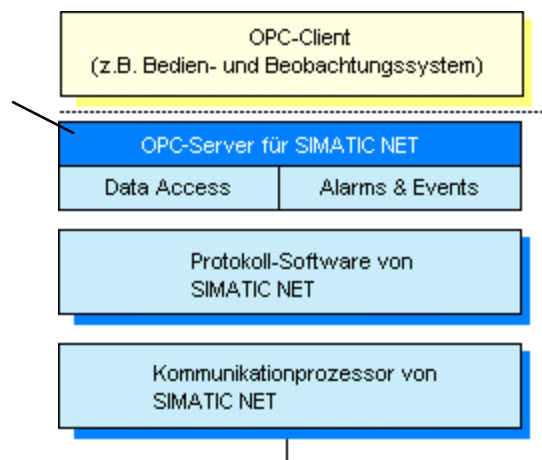

Standard Situation: Using the Default Settings

In the simplest case (in other words, the standard situation), you simply need to create the OPC Server in the PC station. You must also create the communications modules used in the station and plan communication connections.

The steps are described in detail in Section 12 Project Engineering with SIMATIC NCM PC.

Using Default Settings or Project Engineering Parameters

The parameters you can set with NCM PC all have default settings so that in most cases problem-free communication is possible.

5.2 Specifying the Properties of the OPC Server in Project Engineering

To check the properties of the OPC Server or to modify parameters, open the Properties dialog of the OPC server object in STEP 7 / NCM PC.

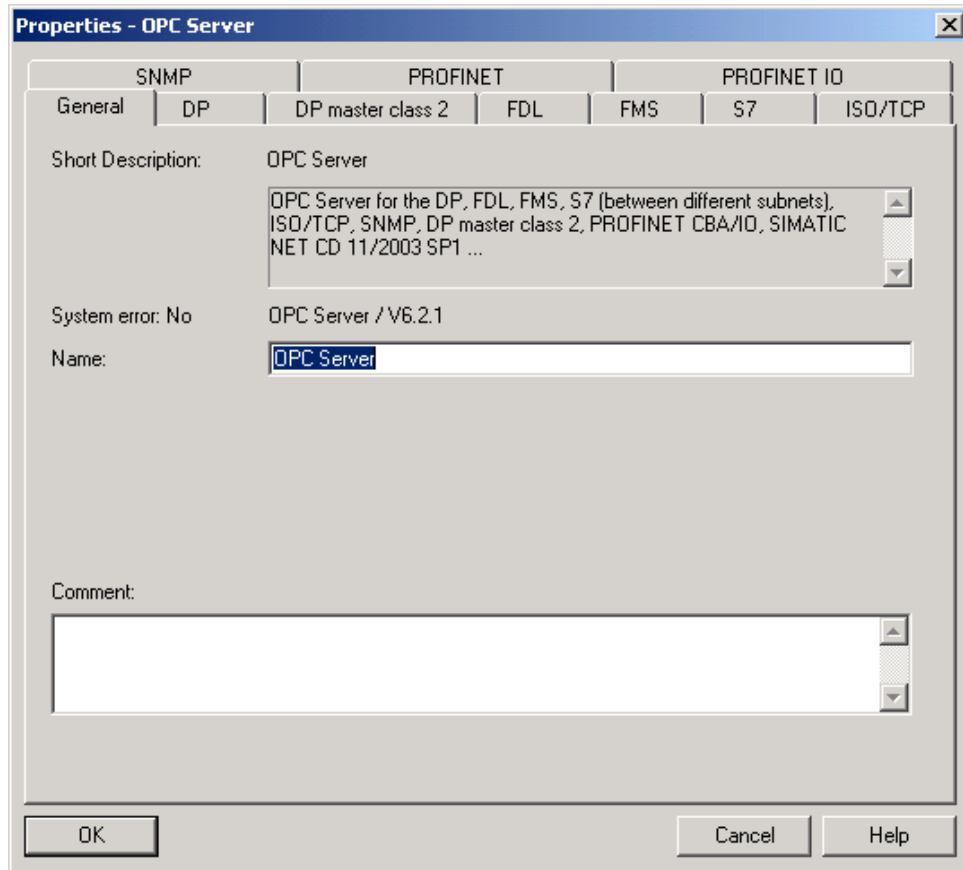

The “General” tab contains the formal parameters for identifying the OPC Server and in the other tabs, you can make parameter settings for the OPC server related to the specific protocols.

These parameters are independent of the communication connections or a DP master system that you configure separately in project engineering.

The table below provides you with an overview of the possible parameter settings depending on the protocol or service type.

Table 5-1

Parameter / Function	Possible Settings / Significance	Can be set for a specific protocol								
		DP	FDL	FMS	S7	ISO/TCP	DP class 2	PROFINet	PROFINet IO	SNMP
Scan cycle time	Here, you make the settings to control updating by the OPC Server. The scan cycle time decides how often the OPC server updates the values the OPC items.	x	x	x	x	x	x	x	x	x
Access protection	You can specify the access rights to individual variables or variable groups for each specific protocol. You can, for example, prevent variables calculated internally by the controller from being overwritten. As default, no access protection is activated.	x	x	x	x	x	x	x	x	x
VFD	VFD (Virtual Field Device) is the neutral description of a device used in FMS. Communication connections (FMS connections) are then configured for the VFDs in project engineering. Here, you inform the OPC server of the required VFDs. During project engineering, you then assign the VFD to the FMS connection. When accessing variables in the PC application, you also reference the VFD. Extra function: creating the object dictionary Here, you can also create the object dictionary (OD) belonging to a VFD. The FMS variables (name and structure) are defined in the object dictionary.			x						
Connection parameters	Here, you can make the settings required for communication for services that do not require specific connections to be configured in project engineering.				x					
Segmentation	Special settings for providing the data buffers independent of specific connections.					x				
Use symbols					x					

Please note that the parameters are described in detail in the online help for each individual dialog in NCM PC.

5.3 Specifying Connection Properties for the OPC Server in Project Engineering

When using OPC, communication connections are established and managed by the OPC Server. As a result, you create the communication connections only for the “OPC Server” application.

How to create a connection for PC applications is described in Section 12.7.

If a connection is created for the OPC Server, the properties dialog for the connection includes an additional tab, “OPC - Properties”.

The dialogs shown below for the various protocols provide you with an overview of the possible settings; in these examples, the parameters have their default settings.

Please note that the parameters are described in detail in the online help for each individual dialog in NCM PC.

Notice

Changes to the default parameter settings should only be made by specialists. Changes can lead to unexpected situations and cause major system disruption.

After changing parameters, they must be downloaded or exported and the import of an XDB started.

FDL Connection (SEND/RECEIVE Interface)

Parameter	Value	Unit
Job timeout:	15000	ms
Max. number of send retries:	5	
Send buffer size:	244	Bytes
Max. number of parallel send jobs:	3	
Number of resources for indications:	1	
Send with higher priority	<input checked="" type="checkbox"/>	

FMS Connection

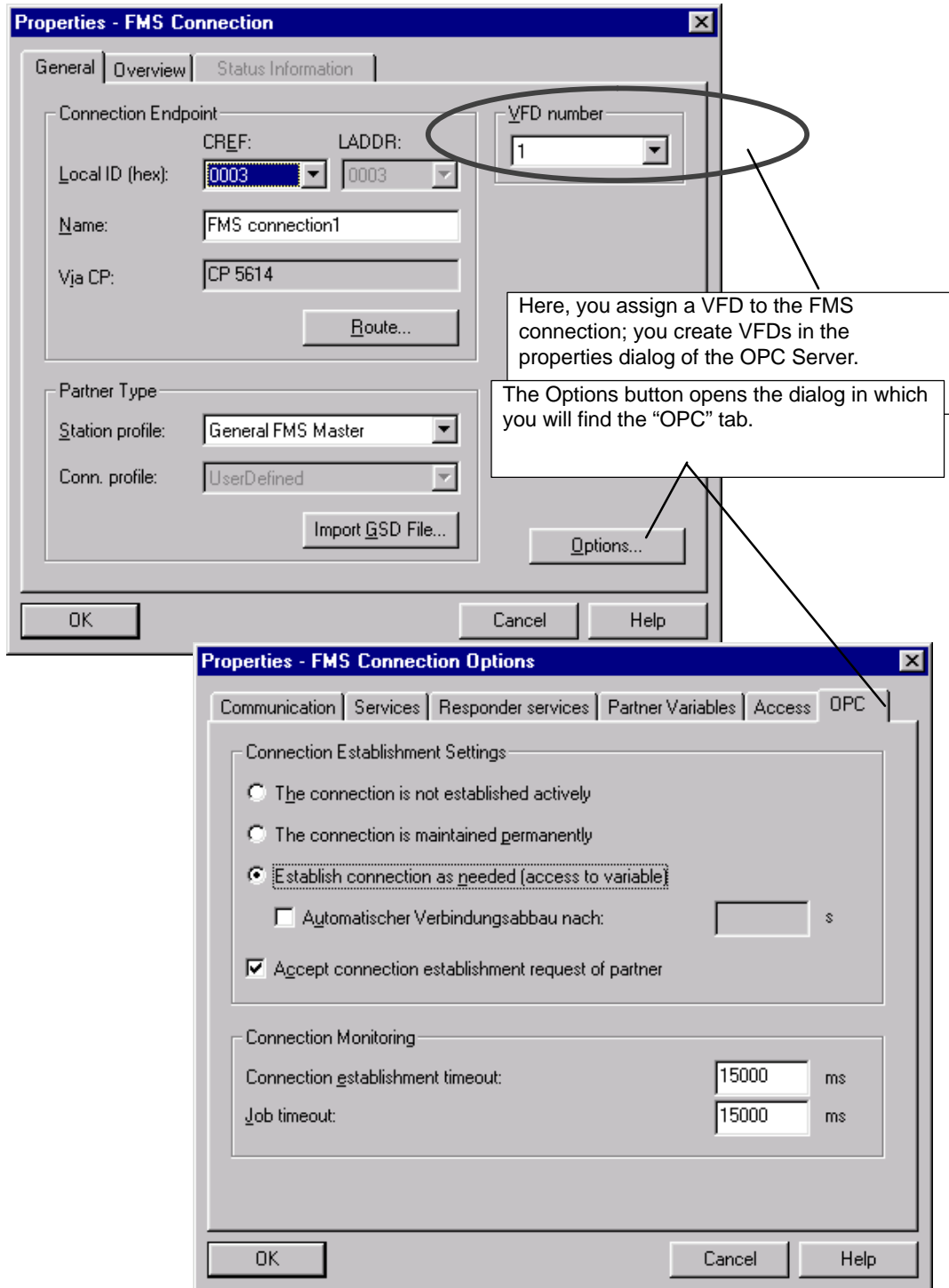

S7 Connection (S7 Communication)

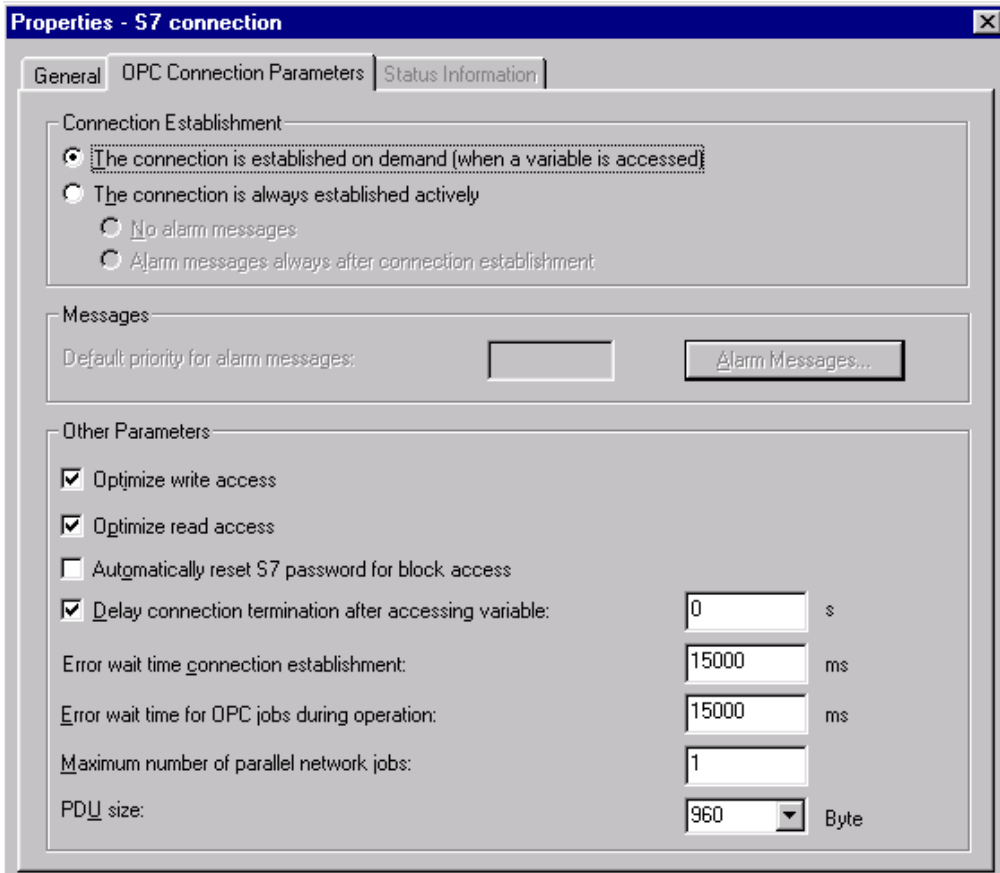

Properties - S7 connection

General | OPC Connection Parameters | Status Information

Connection Establishment

- The connection is established on demand (when a variable is accessed)
- The connection is always established actively
 - No alarm messages
 - Alarm messages always after connection establishment

Messages

Default priority for alarm messages:

Other Parameters

- Optimize write access
- Optimize read access
- Automatically reset S7 password for block access
- Delay connection termination after accessing variable: s
- Error wait time connection establishment: ms
- Error wait time for OPC jobs during operation: ms
- Maximum number of parallel network jobs:
- PDU size: Byte

ISO Transport Connection (SEND/RECEIVE Interface)

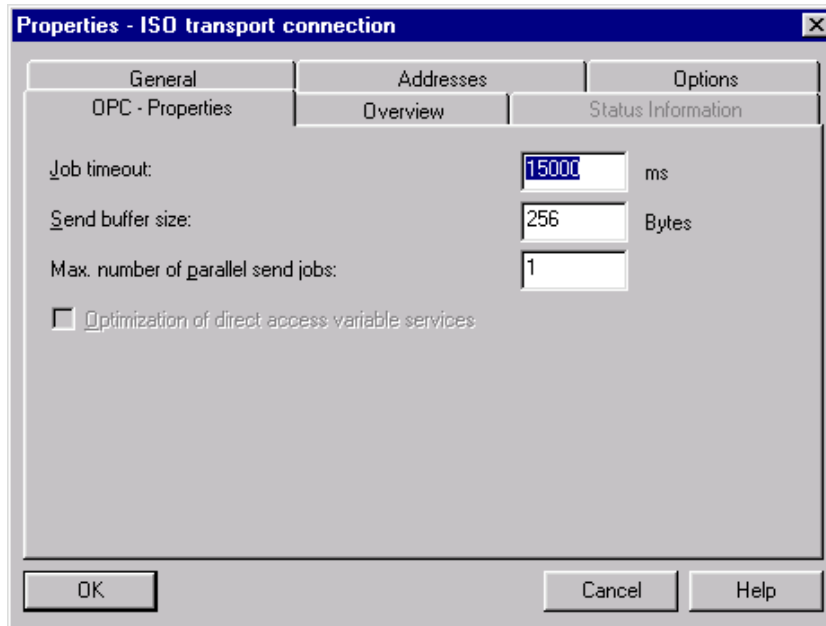

ISO-on-TCP Connection (SEND/RECEIVE Interface)

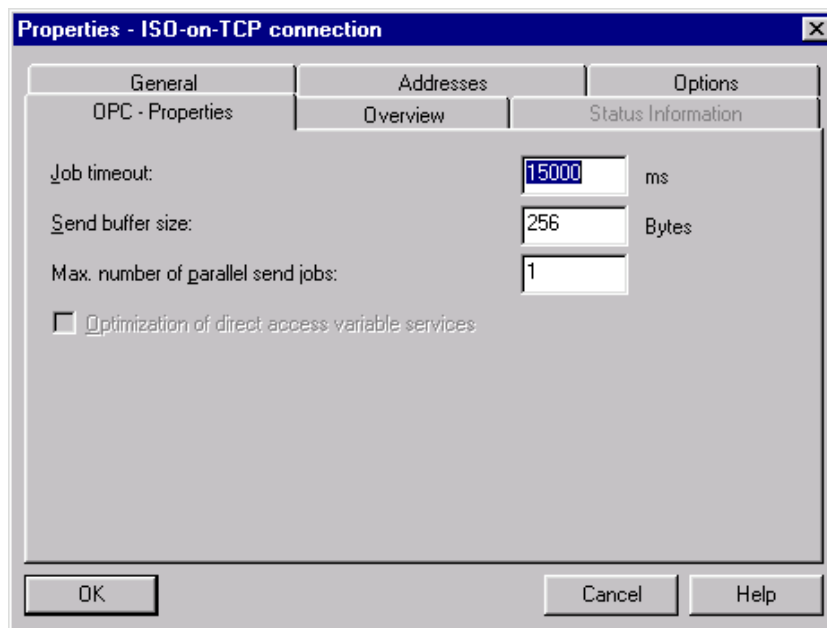

5.4 Using Symbols for S7 Connections

Symbol tables are created during project engineering with STEP 7 on a central engineering station in the form of STI files.

You can continue to use the symbol definitions made in the STEP 7 project engineering when working with OPC. This is necessary if user applications (OPC clients) are to access symbolic variables over the OPC server.

The symbol tables used are those of the CPUs for which S7 connections are planned for the OPC server. Only the symbols that related to data blocks (DBs) are taken into account.

In the "S7" tab of the properties dialog of the OPC server, you can specify which STEP 7 symbols you want to use on the OPC server.

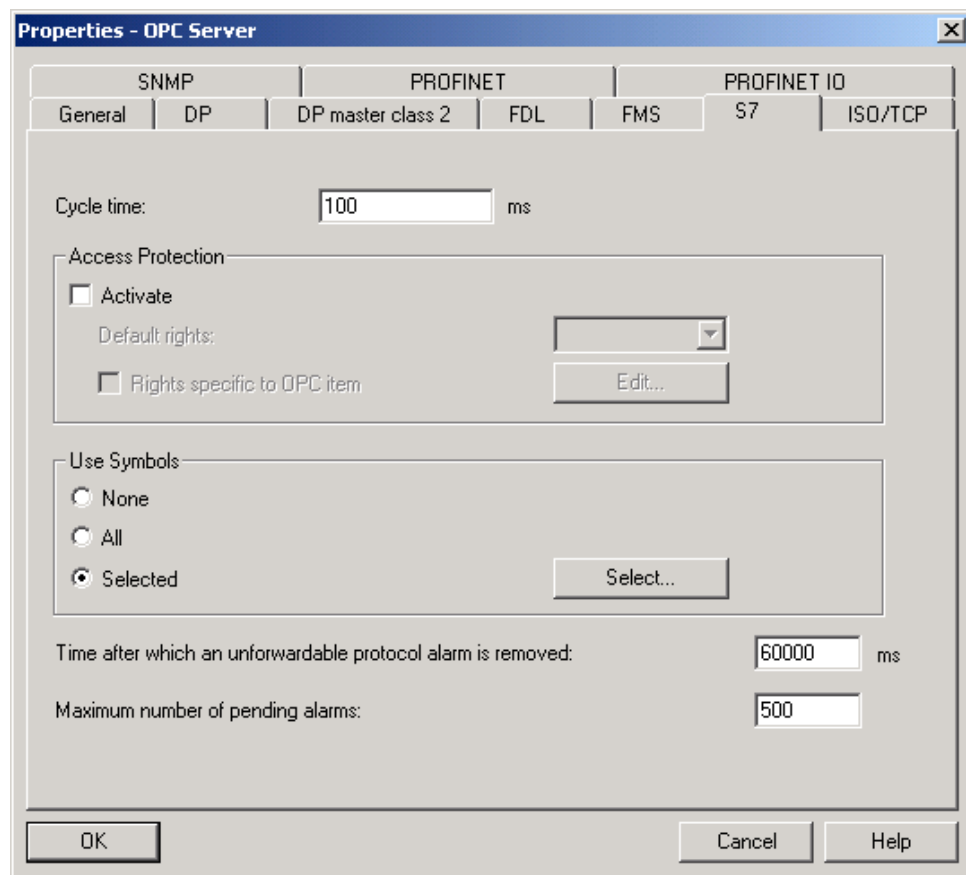

5.5 Configuring OPC Properties for SNMP in Project Engineering

5.5.1 Significance in SIMATIC NET

You configure the OPC server as an SNMP client in the "SNMP" tab by specifying the protocol properties for SNMP for the transfer and a node list for the SNMP queries.

Note

For more detailed information on the use of SNMP over the OPC Server, refer to the documentation for OPC /1/ or the Quick Start in Chapter 9.

You will also find valuable information on the Internet at:

<http://www.siemens.com/snmp-opc-server>

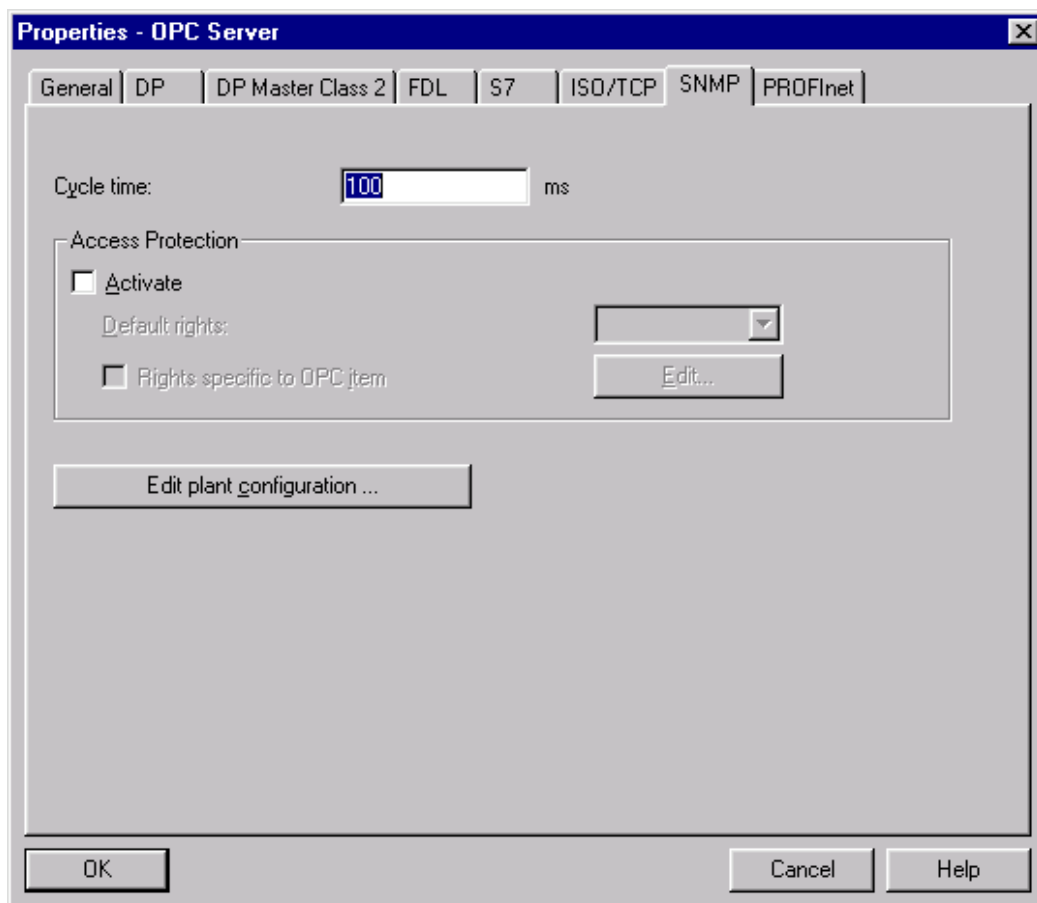

Using the “Edit Plant Configuration” button, you obtain a list with all the devices registered with the OPC server.

You can add others to this list or edit the parameters of the entered devices.

Device Profiles on the SIMATIC NET Software CD

Device profiles are available for the following modules on the SIMATIC NET Software CD:

- CP 1613 --> MIBII_V10.txt (supports only MIBII objects)
- OSM --> Profil_OSM_V10.txt
- ELS --> Profil_ELS_TP40_V10.txt

These files are stored in the following folder:

<installationdrive>\Programs\Siemens\simatic.ncm\S7data\SNMP\Profile

Note

Please read the detailed description of the parameters in the online help of the dialog in STEP 7 / NCM PC.

5.5.2 SNMP Traps

Introduction

Traps are messages that can be sent to the OPC Server without it requesting them. There are seven generic traps available on every SNMP-compliant device. There are also device-specific traps that are described in the MIB file.

Generic Traps

Parameter	Meaning
warmStart	This is sent after a warm restart on the device.
coldStart	This is sent after a cold restart on the device.
linkDown	This is sent when a connection from the device disconnects.
linkUp	This is sent when a connection from the device is established.
authenticationFailure	This is sent when there was unauthorized access to the device.

Parameter	Meaning
egpNeighborLoss	The EGP neighbor (EGP = Exterior Gateway Protocol) of the device is not operational. The Exterior Gateway Protocol is used to exchange routing information between two neighboring gateway hosts.
enterpriseSpecific	This is sent when a device-specific trap was sent.

□

6 Example — OPC Application for Industrial Ethernet

6.1 Overview

Explanation of the Configuration Example

This example illustrates how you can connect an S7-400 programmable controller with a PC station over Industrial Ethernet.

In the configuration example presented here, typical communication partners are connected to Industrial Ethernet and can be reached over the OPC server.

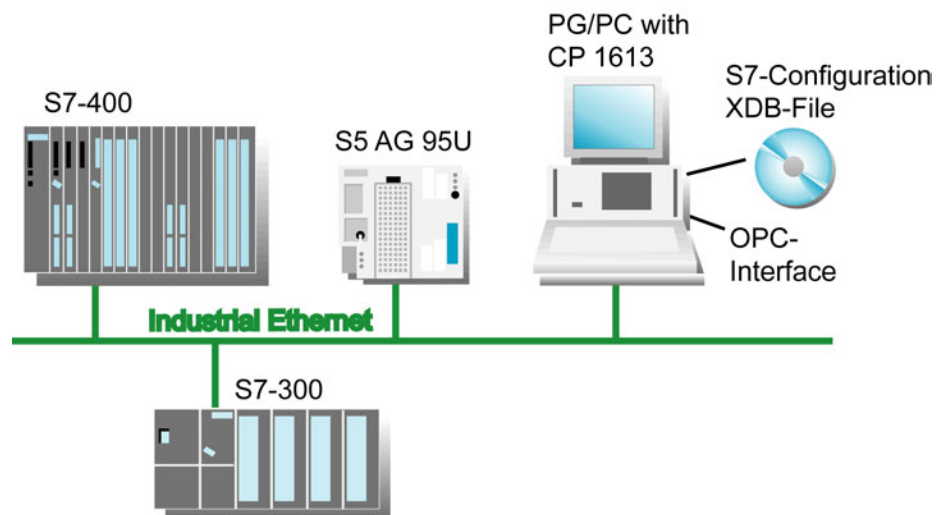

Example of an Industrial Ethernet Configuration

Communication takes place between two devices or modules. Communication with an S7-400 station using the S7 protocol is described in detail below.

You will see which tools are used for planning a PC station in the project engineering for connecting to an S7-400. You will see how symbolic variables in the S7 program are made available in OPC. You will also see how to use the OPC Scout program that is supplied with the product for communication with the OPC Server.

Initial Situation

If you want to try out the example yourself, you require the following:

- a PC
- a communication module for Industrial Ethernet (CP 1613)
- the SIMATIC NET CD 11/2003 software
- an S7-400 with a CP 443-1
- Industrial Ethernet cabling between the PC module and S7 device

For the S7-400 device and the PC station, you require a STEP 7 project that was created on a central ES station (not this PC station).

In the project, you specify the hardware configuration and the programs and data blocks and define a symbol table.



6.2 Hardware and Software Installation

Installing the Software

Activity	
1.	Turn on the PC and start Windows.
2.	Insert the SIMATIC NET 11/2003 CD. If the installation program does not start the CD automatically, start the start.exe program on the CD.
3.	Follow the on-screen instructions of the installation program.

Installing the CP 1613

Activity	
1.	Shut down the PC and turn it off.
2.	Disconnect the power cable.
3.	Read the instructions for installing cards in the manufacturer's instructions for your PC.
4.	Insert the CP 1613 module in a PCI slot.
5.	Reassemble the PC as described in the instructions of the PC manufacturer and reconnect the power cable.

Attaching to the Network

Activity	
1.	Connect the Ethernet cable to the CP 1613.
2.	Connect the S7-400 device to the network cable.

6.3 Creating the STEP 7 Project

6.3.1 STEP 7 Project Engineering on a Central Engineering Station

In the requirements, we have already said that you require a STEP 7 project for this example. Below, you will find a brief outline of how such a project is created.

Activity	
1.	Create a project in the SIMATIC Manager.
2.	Insert a SIMATIC 400 station and a SIMATIC PC station.
3.	Create the hardware configuration including the network assignment and parameter settings of the CPs.
4.	Save and compile the configuration.

Index	Module	Order number	Firmware	MPI ...	Comm...
1	OPC Server		V6.1.0		
2	CP 1613	6GK1 161-3AA00	V6.0.5		
3					
4					
5					
6					
7					
8					
9					

Press F1 to get Help.

Result: The current configuration is saved in the project, system data blocks are created, the XDB file is created and any system errors are displayed.

Activity

In NetPro, you will find the network assignment of the SIMATIC 400 station and the PC station displayed graphically.

The screenshot shows the NetPro software interface. The main window displays a network diagram with two stations: an S7-400 station (CPU 416-1, CP 443-1) and a KH1F150D station (OPC Server, CP 1613). The S7-400 station is connected to the KH1F150D station via an S7 connection. The network is labeled 'Ethernet(1) Industrial Ethernet' and 'MPI(1) MPI'. Below the diagram is a table with the following data:

Local ID	Partner ID	Partner	Type	Active	Subnet	Partner interface
1	S7-Verbindung_1	KH1F150D / OPC Server	S7 connection	No	Ethernet(1) (IE)	CP 1613
2	S7-Verbindung_2	KH1F150D / OPC Server	S7 connection	No	Ethernet(1) (IE)	CP 1613

6.3.2 Using Symbol Files

Introduction

Symbol tables are created during project engineering with STEP 7 on a central engineering station in the form of STI files.

You can continue to use the symbol definitions made in the STEP 7 project engineering when working with OPC. This is necessary if user applications (OPC clients) are to access symbolic variables over the OPC server.

The symbol tables used are those of the CPUs for which S7 connections are planned for the OPC server. Only the symbols that related to data blocks (DBs) are taken into account.

Make the settings described in “Specifying the Use of Symbol Files” for the OPC server on the central engineering station.

Specifying the Use of Symbol Files

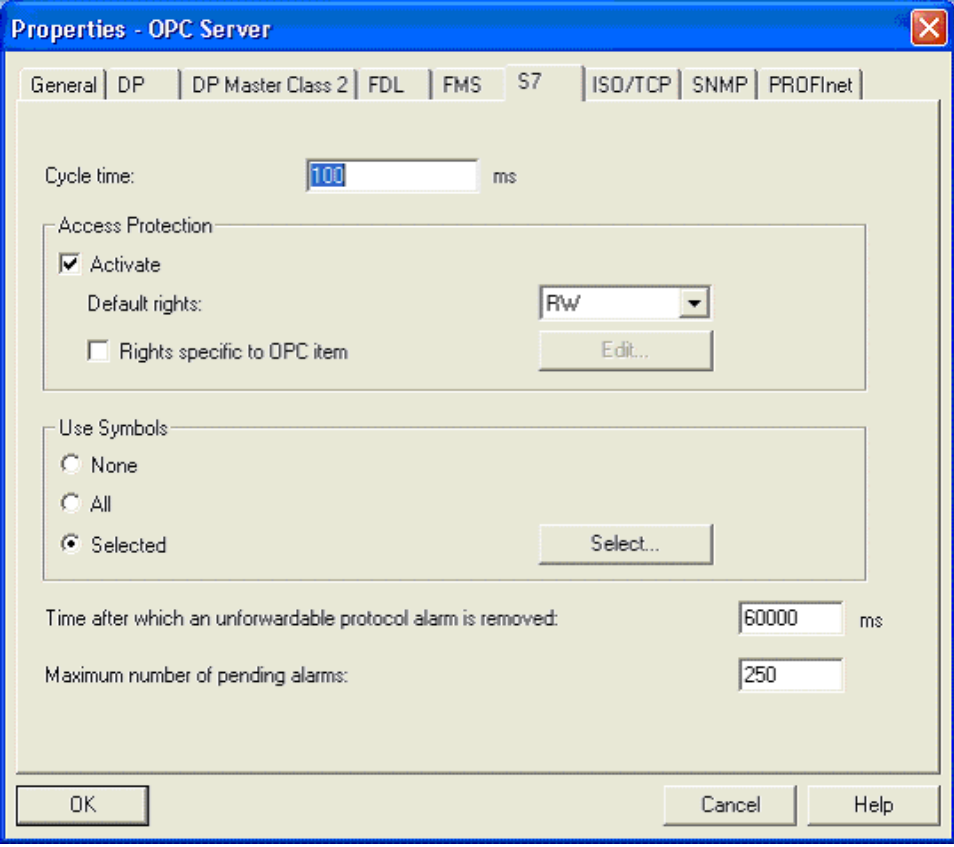
Activity	
1.	Select the “OPC server” in the “PC station” in “HW Config” (or NetPro) and select “Object Properties” in the context menu. Result: The properties dialog of the OPC server opens.
2.	Go to the “S7” tab. In this dialog, you can specify which STEP 7 symbols you want to use on the OPC server. In this case, choose the “Selected” option. 

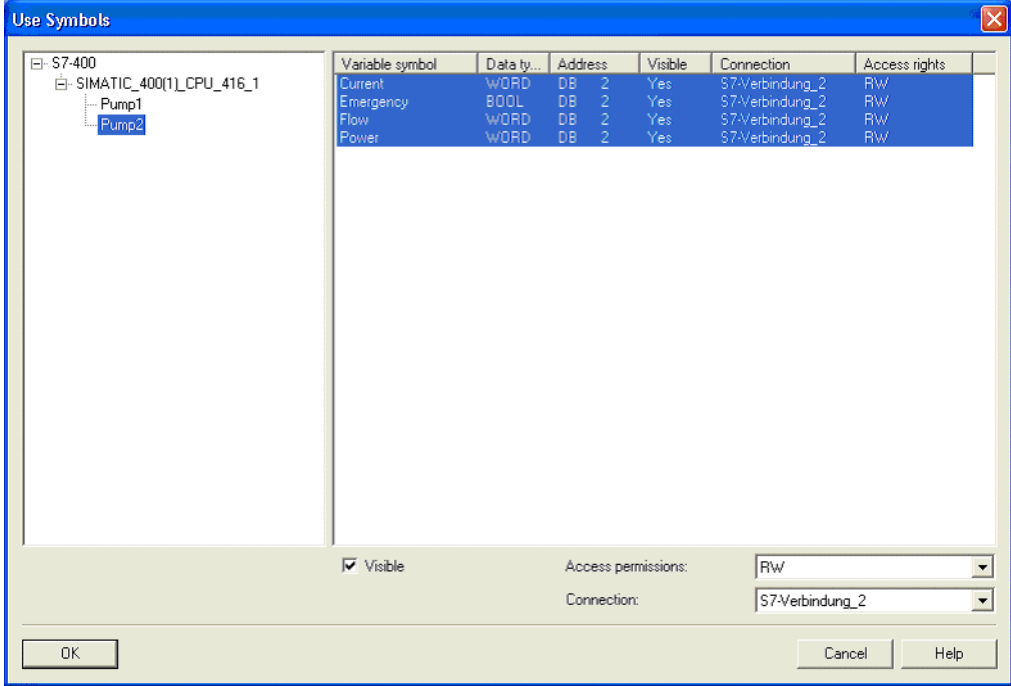
Activity	
3.	<p>Click the “Select” button.</p> <p>Result: The “Use Symbols” dialog opens. In this dialog, you can specify which symbols you want to use and can configure them.</p>  <p>Confirm the dialog with “OK”.</p>
4.	<p>Also confirm the properties dialog of the OPC server with “OK”.</p> <p>Result: You return to HW Config. All the symbols specified in the STEP 7 project engineering are available in the OPC server.</p>
5.	<p>Save and compile the project with the Station ► Save and Compile menu command and select the option “Compile and check everything” to update the information in the project.</p>
6.	<p>Close HW Config.</p>

6.4 Configuring the PC Station

Overview

After starting the PC station, after installing the software and installing the CP 1613, the CP 1613 is in PG operation.

Handling the Project Engineering Data

Depending on the case, two situations must be distinguished (see Section 2.1):

- Project engineering before initial configuration - XDB file available
- Initial configuration not dependent on project engineering

In this example, we assume that the project engineering data is available in the form of an XDB file that was created on an external engineering station. The XDB file is transferred to the local PC station on a data storage medium. The initial configuration is then done with "Import station" (XDB import) in the Station Configuration Editor.

To allow the information from the project engineering to be transferred from the engineering system to the PC station, the local configuration must match the configuration data entered in the project engineering.

Procedure for “Initial Configuration”

1. Start the Station Configuration Editor by selecting it in the start menu (**Start ▶ Station Configuration Editor**).

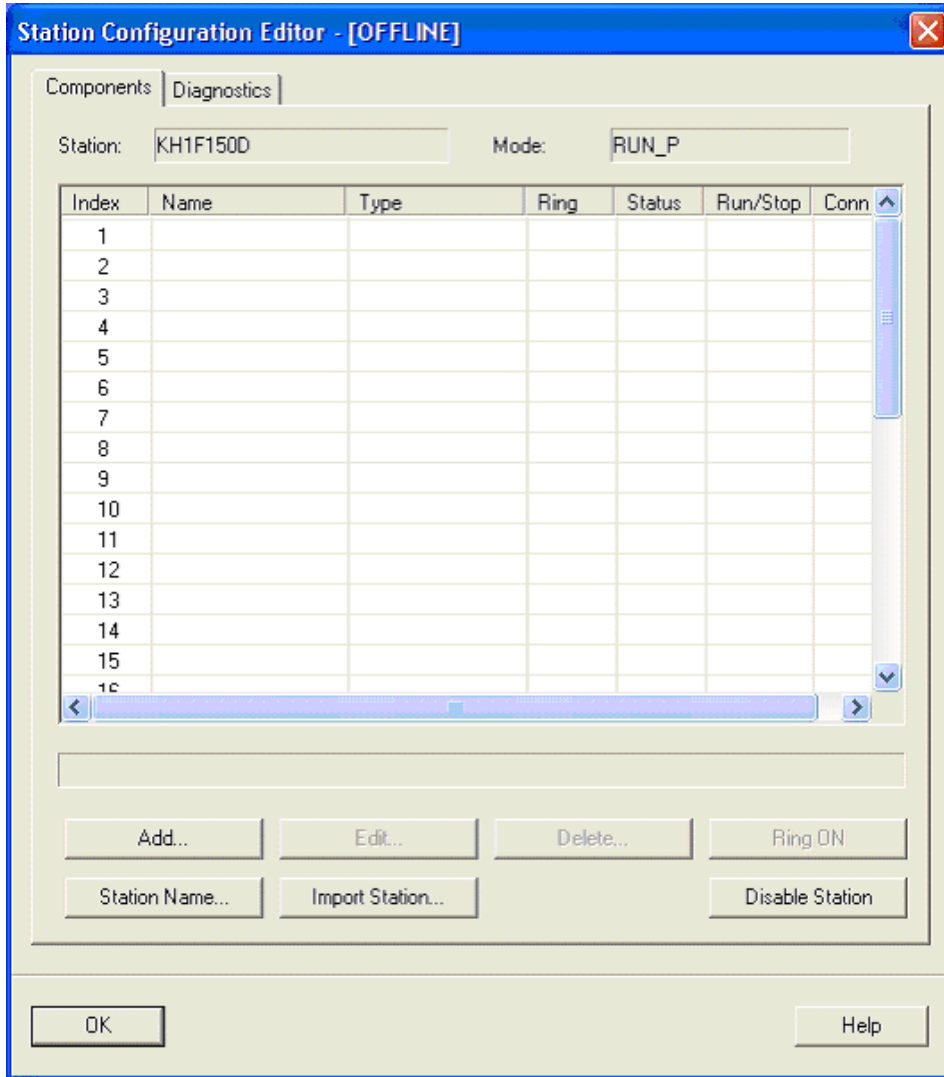

Procedure for “Initial Configuration”

2. Click the “Import Station” button, select the XDB file that you want to import and confirm the dialog with “OK”.

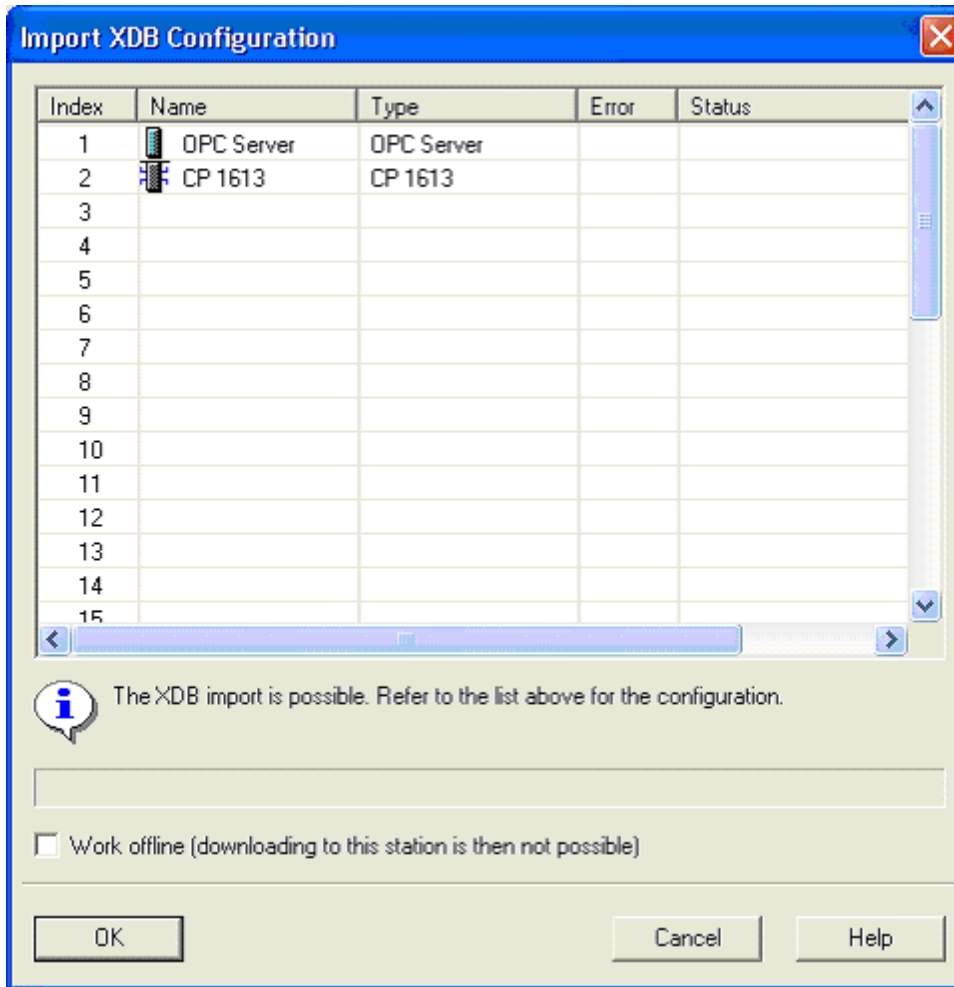

Procedure for “Initial Configuration”

3. Result: All the communication data created with S7 is now on the PC station. The CP 1613 is in the “configured mode”.
PC configuration is complete.

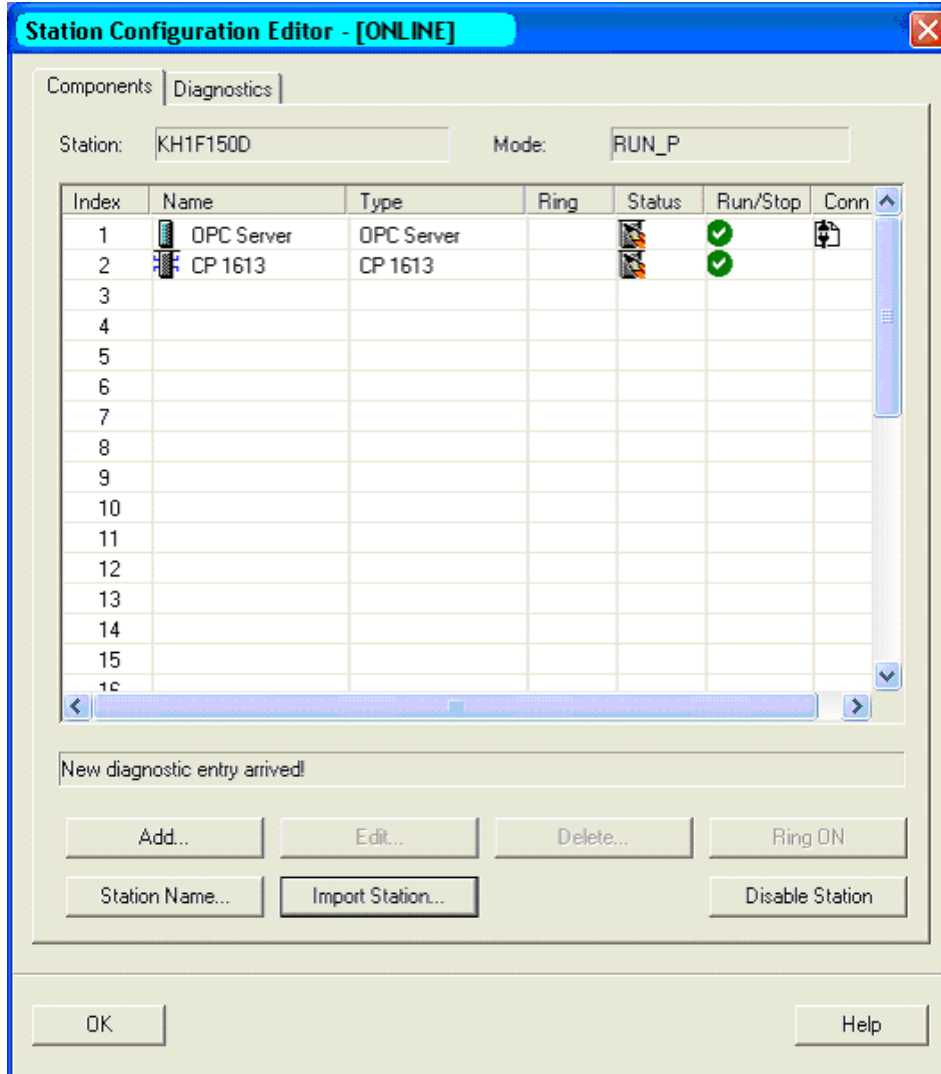

6.5 Using the OPC Scout

6.5.1 Establishing a Connection to the Server

The OPC Scout as Client for Commissioning and Testing

You can now access the data objects of the S7 station with any OPC client. The OPC Scout ships with this product as the tool for commissioning and testing.

Follow the steps below to read the inputs and set the outputs with the OPC Scout:

Activity	
1.	Start the OPC Scout from the start menu: (Start ▶ SIMATIC ▶ SIMATIC NET ▶ Industrial Ethernet ▶ CP1613 ▶ OPC Scout).
2.	Double-click the “OPC.SimaticNET” entry to link the OPC Scout with the OPC Server. The OPC Server is started.

6.5.2 Inserting a Group and Variables

Organizing Process Variables

The process variables of the OPC server (known as OPC items) are assigned to groups. You therefore require an OPC group before you can insert OPC items. Follow the steps outlined below to create a group and add items to it:

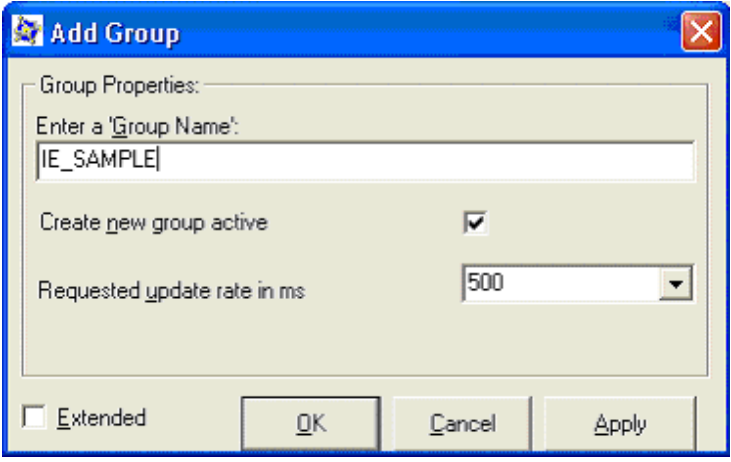
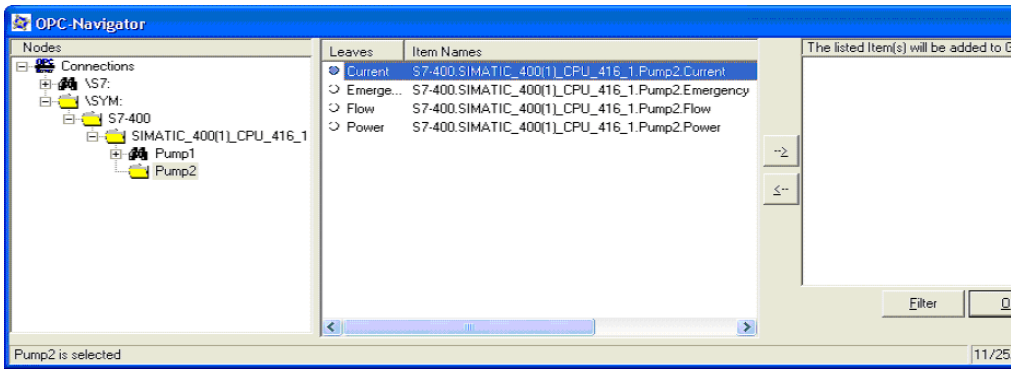
Activity	
1.	<p>After the OPC Server starts, a dialog opens in which you can create a group. Enter "IE_Sample" as the group name and confirm your input with "OK":</p> 
2.	<p>Double-click on the group entry "IE_SAMPLE" to open the OPC Navigator. In the left-hand pane, you will see the hierarchically arranged name space of the OPC variables.</p>
3.	<p>If you click on an element in the tree (here pump 2), the OPC items defined for this element appear in the middle pane of the window:</p> 

Activity

4. Select the following OPC items from the appropriate branches in the middle window and transfer these variables to the right-hand pane by clicking on the arrow button.

Examples:

SIMATIC_400(1)_CPU_416-1.Pump2.Current

SIMATIC_400(1)_CPU_416-1.Pump2.Emergency

SIMATIC_400(1)_CPU_416-1.Pump2.Flow

SIMATIC_400(1)_CPU_416-1.Pump2.Power

The items are added to the group after you confirm the dialog with "OK".

6.5.3 Displaying and Modifying Values of Variables

Executing Synchronous Write Jobs

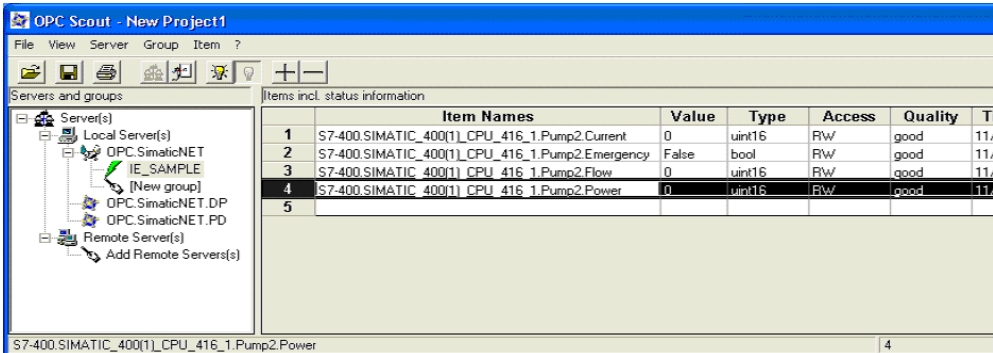
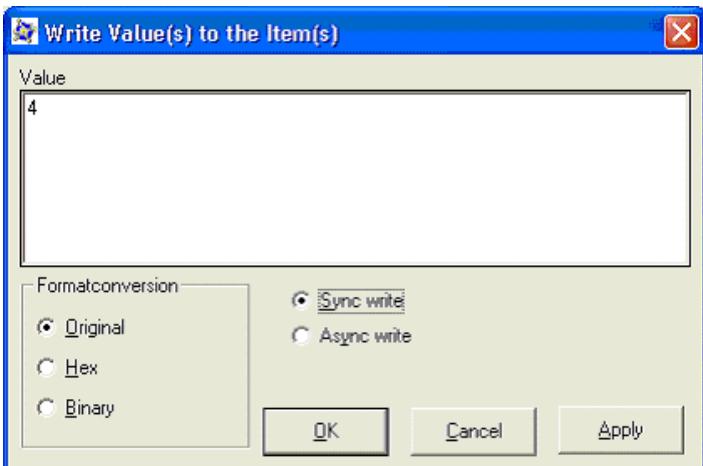
Activity	
1.	<p>The selected variables are displayed with the following additional information in the table of the main window:</p> <ul style="list-style-type: none"> ● The current value of the item ● Access Rights ● Information about the integrity of the data ● Time Stamp 
2.	<p>Now double-click on the “Value” cell of one of the variables, for example on the “0” of the first OPC item. A dialog opens in which you can change the value of the variable.</p>
3.	<p>Enter, for example, the value 4 in the “Value” input field to write the value 4 to the variable:</p> 
4.	<p>Confirm with “OK” to execute the write job.</p>



7 Example — OPC Application for PROFIBUS-DP

7.1 Overview

Explanation of the Configuration Example

This example illustrates how to connect an ET 200 B DP slave with a CP 5613 in a PC station over PROFIBUS DP.

In the configuration example presented here, typical communication partners are connected to PROFIBUS and can be reached over the OPC server.

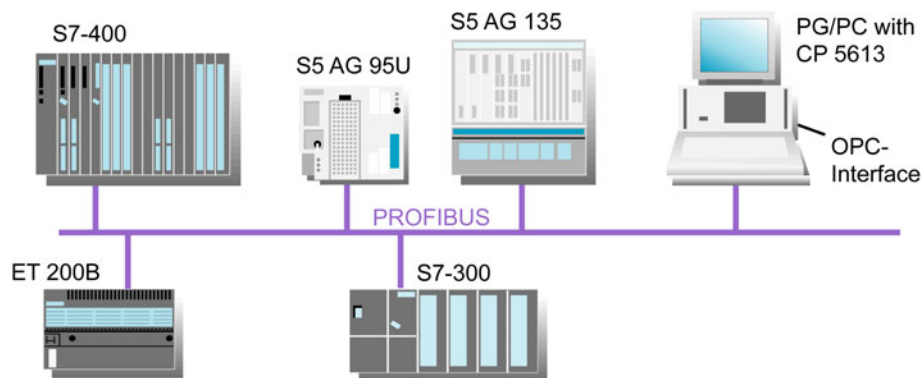

Example of a PROFIBUS Configuration

Communication takes place between two devices or modules. Communication with an ET 200 B is described in detail.

You will see which tools are used for configuration and project engineering of a PC station and a DP slave. You will also see how to use the OPC Scout program for communication with the OPC Server.

Initial Situation

If you want to try out the example yourself, you require the following:

- a PC
- the communication module for PROFIBUS (CP 5613)
- The software of the SIMATIC NET CD 11/2003 (NCM installed)
- an ET 200B DP slave
- PROFIBUS cabling between the PC module and ET 200B



7.2 Hardware and Software Installation

Installing the Software

Activity	
1.	Turn on the PC and start Windows.
2.	Insert the SIMATIC NET 11/2003 CD. If the installation program does not start the CD automatically, start the start.exe program on the CD.
3.	Follow the on-screen instructions of the installation program. Install the SIMATIC NET software and SIMATIC NCM PC.

Installing the CP 5613

Activity	
1.	Shut down the PC and turn it off.
2.	Disconnect the power cable.
3.	Read the instructions for installing cards in the manufacturer's instructions for your PC.
4.	Insert the CP 5613 module in a PCI slot.
5.	Reassemble the PC as described in the instructions of the PC manufacturer and reconnect the power cable.

Attaching to the Network

Activity	
1.	Connect the PROFIBUS cable to the CP 5613 (DP master).
2.	Connect the ET 200B (DP slave) to the PROFIBUS cable.
3.	Check the terminators on the connectors. The terminators at both ends of the cable must be activated ("On").

7.3 Configuring the PC Station

Overview

After starting the PC station, after installing the software and installing the hardware, the CP 5613 is in PG operation.

By adding the CP 5613 in the Station Configuration Editor, the module is automatically switched to the “configured mode”.

Handling the Project Engineering Data

Depending on the case, two situations must be distinguished (see Section 2.1):

- Project engineering before initial configuration - XDB file available
- Initial configuration not dependent on project engineering

In this example, we assume that no project engineering data is available in the form of an XDB file. The initial configuration is therefore specified in the Station Configuration Editor.

The initial configuration specified with the Station Configuration Editor can later be transferred to the central engineering station on which the automation solution is created.



Procedure for “Initial Configuration”

1. Start the Station Configuration Editor by selecting it in the start menu (**Start ▶ Station Configuration Editor**).

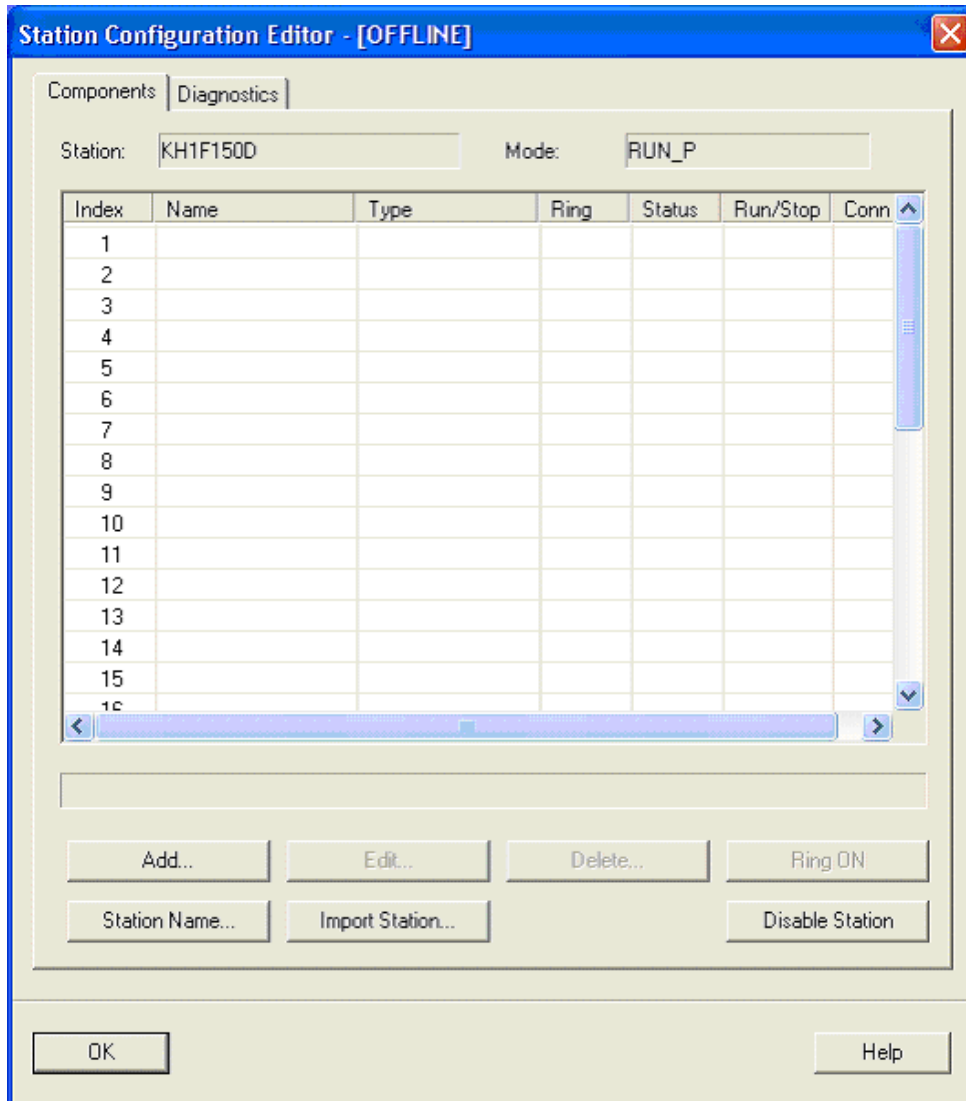

2. Using the “Add” button, add the OPC server to be operated on the station. Confirm the dialog with “OK”.
3. Using the “Add” button, select the CP 5613.

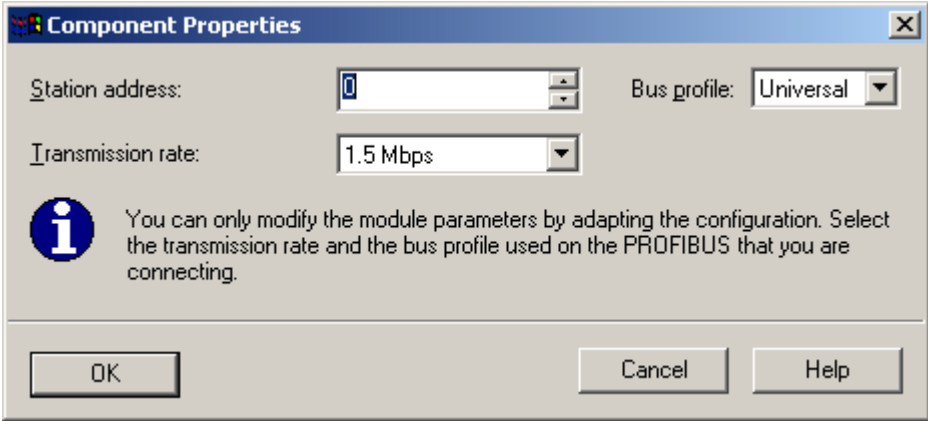
Procedure for “Initial Configuration”	
4.	<p>Check whether the settings of the module match the local configuration.</p> 
5.	<p>Confirm the configuration with “OK”. Result: The CP 5613 is in the “configured mode”. PC configuration is complete.</p>

7.4 Changing the configuration on the PC station

Below, you will see how to expand the hardware configuration of the local PC station by a DP master system and a DP slave using the PC Station Wizard.

7.4.1 Changing the Hardware Configuration - Preparations

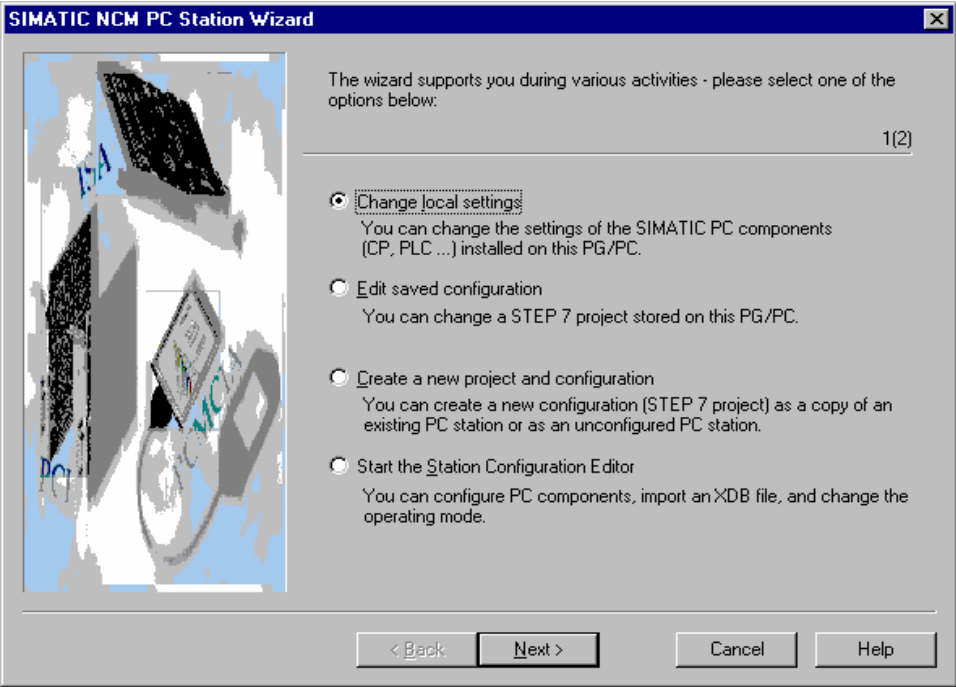
Activity	
1.	Start the PC Station Wizard by double-clicking on the icon (SIMATIC NCM PC Station Wizard) on your desktop.
2.	<p>Select the "Change local settings" option to change the settings of the CP 5613:</p> 
3.	<p>Click the "Next" button. Result: The "Change Settings" dialog is displayed.</p>

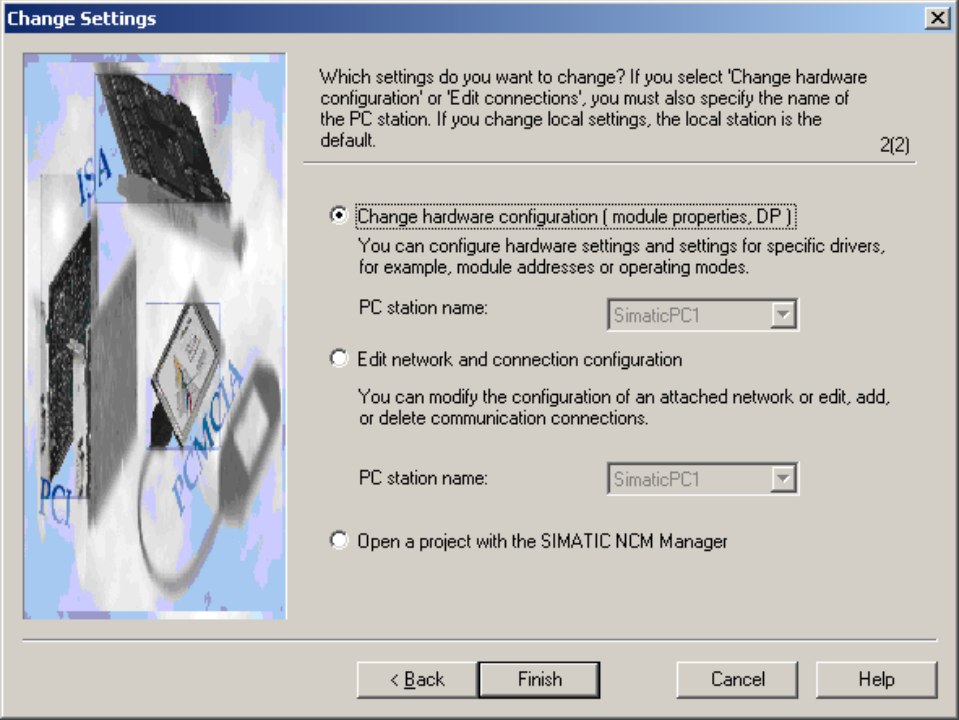
Activity	
4.	<p>Select the project property you want to edit first. For DP project engineering, select the “Change hardware configuration (module properties, DP)” option:</p> 
5.	<p>Click the “Finish” button. Result: SIMATIC NCM PC Config is started.</p>

7.4.2 Inserting a DP Master System

CP 5613 as DP Master

In the STEP 7 project, a SIMATIC PC station was created as an image of the local PC. This PC station already includes the OPC server as the basic component for productive communication and the CP 5613.

You require a DP master system so that you can assign DP slaves. For the DP mode, a DP master system must therefore be added to the CP 5613:

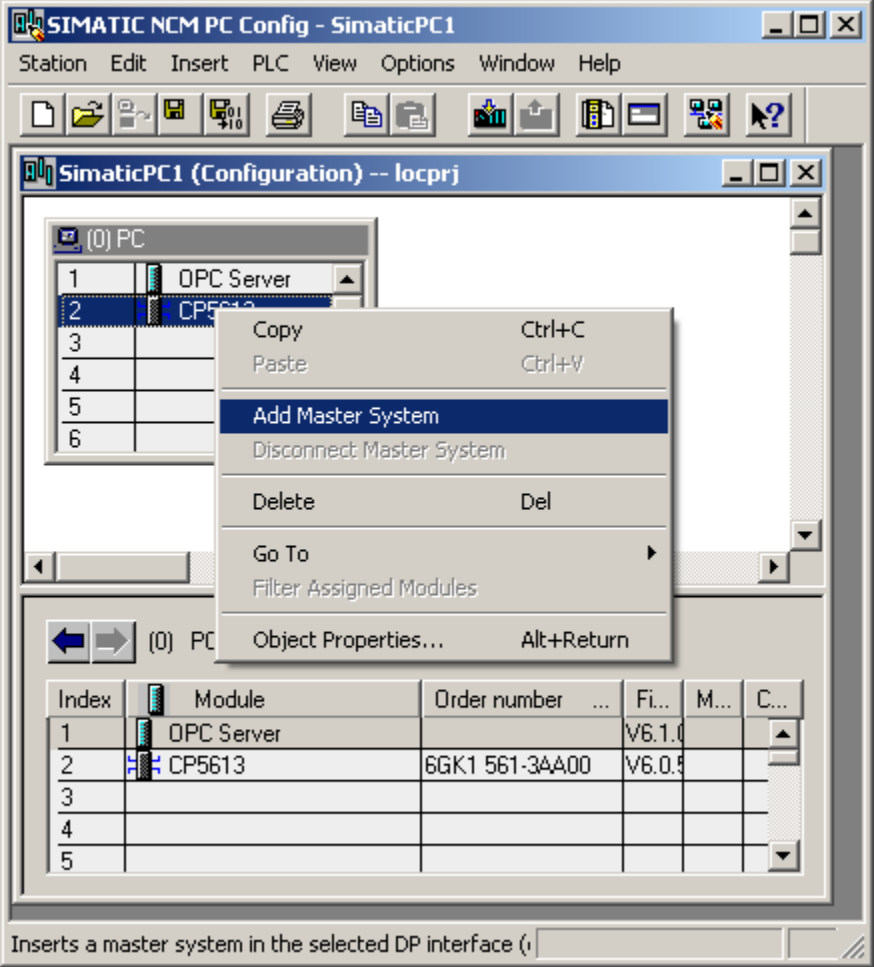
Activity																																					
1.	<p>Select the entry for the CP 5613 and right-click to open the context-sensitive menu for this component.</p>  <table border="1" data-bbox="395 1456 1157 1657"> <thead> <tr> <th>Index</th> <th>Module</th> <th>Order number ...</th> <th>Fi...</th> <th>M...</th> <th>C...</th> </tr> </thead> <tbody> <tr> <td>1</td> <td>OPC Server</td> <td></td> <td>V6.1.0</td> <td></td> <td></td> </tr> <tr> <td>2</td> <td>CP5613</td> <td>6GK1 561-3AA00</td> <td>V6.0.5</td> <td></td> <td></td> </tr> <tr> <td>3</td> <td></td> <td></td> <td></td> <td></td> <td></td> </tr> <tr> <td>4</td> <td></td> <td></td> <td></td> <td></td> <td></td> </tr> <tr> <td>5</td> <td></td> <td></td> <td></td> <td></td> <td></td> </tr> </tbody> </table> <p>Inserts a master system in the selected DP interface (i</p>	Index	Module	Order number ...	Fi...	M...	C...	1	OPC Server		V6.1.0			2	CP5613	6GK1 561-3AA00	V6.0.5			3						4						5					
Index	Module	Order number ...	Fi...	M...	C...																																
1	OPC Server		V6.1.0																																		
2	CP5613	6GK1 561-3AA00	V6.0.5																																		
3																																					
4																																					
5																																					
2.	<p>Select the “Add Master System” menu command. Result: The DP master system is inserted.</p>																																				

7.4.3 Inserting a DP Slave

ET 200B as DP Slave

In this section, you insert an ET 200B as DP slave and assign it to the DP master system.

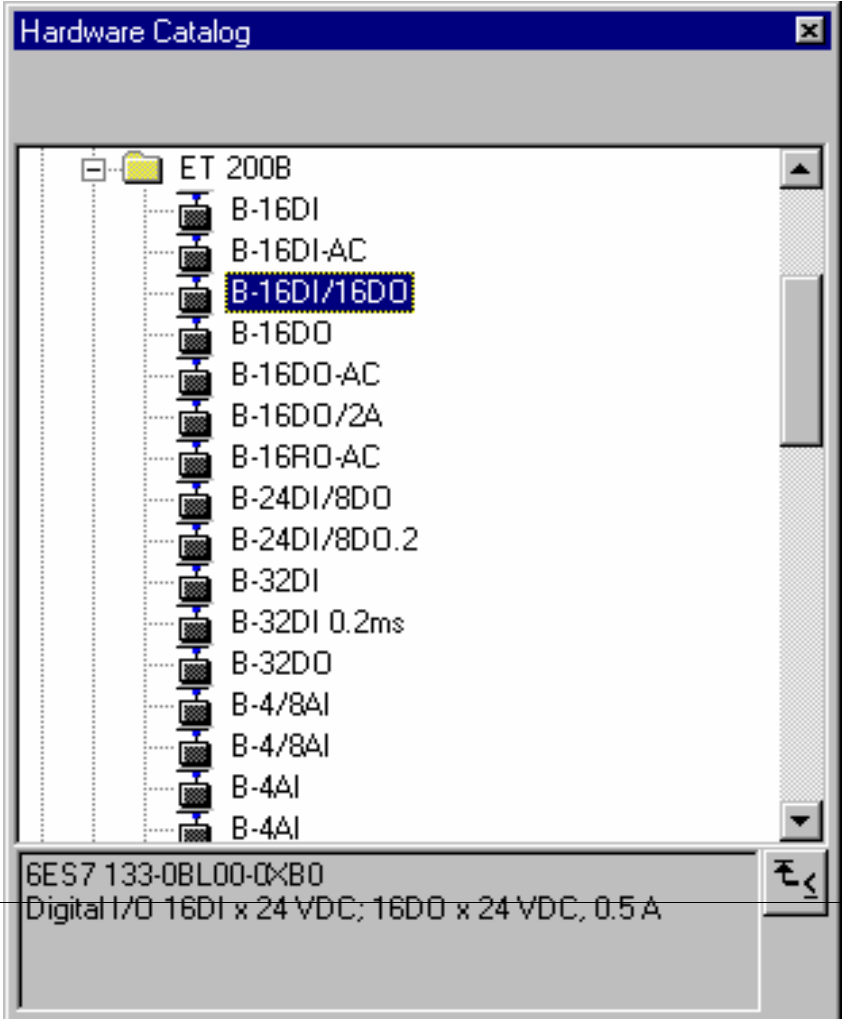
Activity	
1.	<p>Open the catalog in the right pane of the application window. If it is not already displayed, open the catalog by clicking on the following button:</p> 
2.	<p>Select the DP Slave ET 200B with 16 digital input and output bits in the catalog:</p>  <p>The screenshot shows a 'Hardware Catalog' window with a tree view. The 'ET 200B' folder is expanded, and the 'B-16DI/16DO' module is selected and highlighted. Below the list, the selected module's details are shown: '6ES7 133-0BL00-0XB0' and 'Digital I/O 16DI x 24 VDC; 16DO x 24 VDC, 0.5 A'.</p>

Activity

3. Holding down the left mouse button, drag the DP slave to the DP master system until the mouse pointer touches the DP master system (shown as an alternating dark and light shaded line in the display). Release the mouse button when the “+” symbol appears attached to the mouse pointer. Confirm the “Properties - PROFIBUS Interface” dialog with “OK”.
Result: The DP slave is then included in the project.

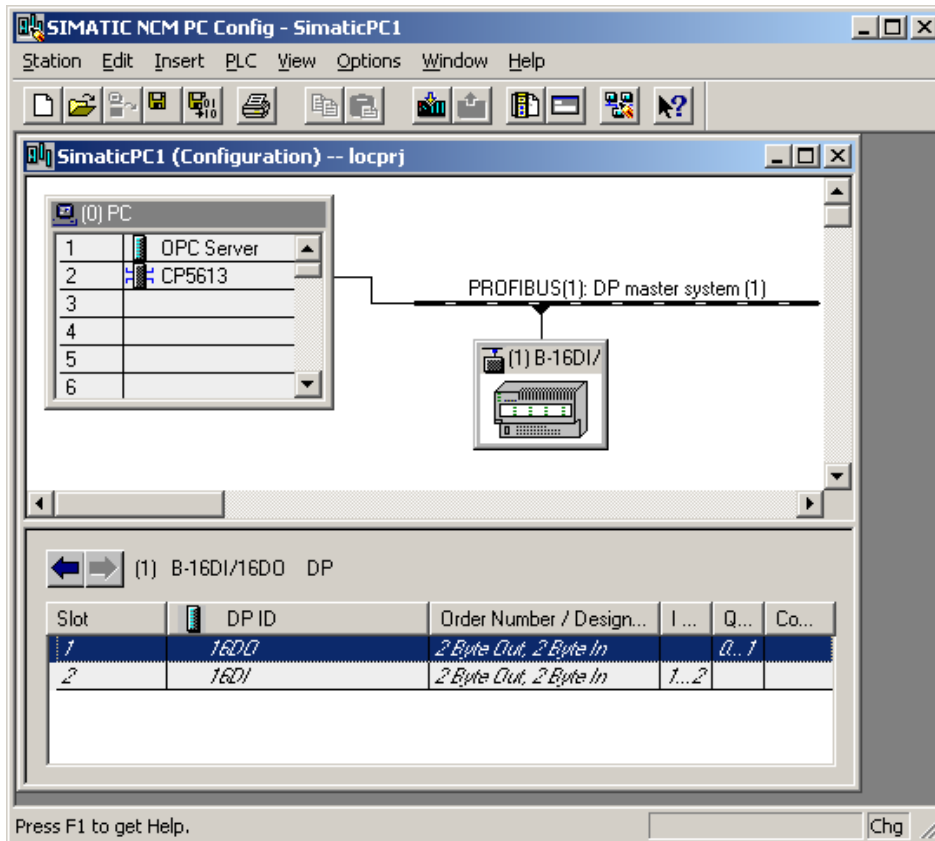

4. Save and compile the project engineering data by clicking the button below:



5. Click the button below to download the project engineering configuration:



Result: The hardware configuration of the station is downloaded to the automation system.

6. Close hardware configuration.

7.5 Using the OPC Scout

7.5.1 Establishing a Connection to the Server

The OPC Scout as Client for Commissioning and Testing

You can now access the objects of the programmable controller with any OPC client. The OPC Scout ships with this product as the tool for commissioning and testing.

Follow the steps below to set the values of the variables of the DP slave with the OPC Scout:

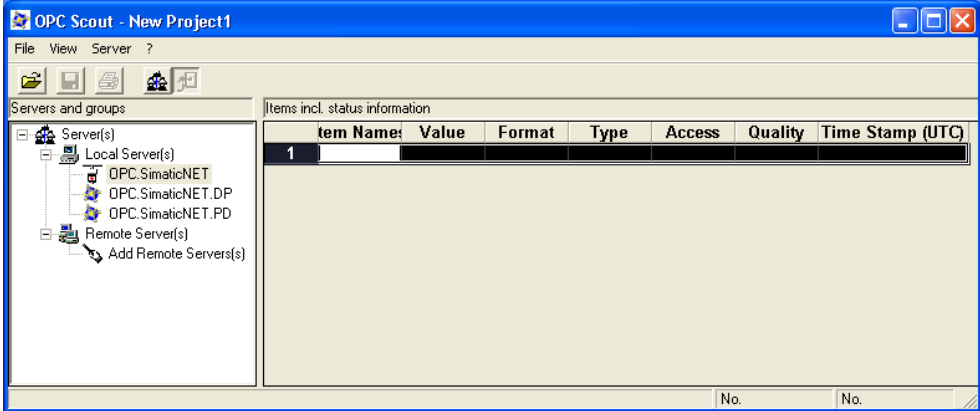
Activity	
1.	<p>Start the OPC Scout from the start menu: Start ▶ SIMATIC ▶ SIMATIC NET ▶ PROFIBUS ▶ CP5613_CP6514 ▶ OPC Scout</p> 
2.	<p>Double-click the “OPC.SimaticNET” entry to link the OPC Scout with the OPC Server.</p>

7.5.2 Inserting Groups and Variables

Organizing Process Variables

The process variables of the OPC server (known as OPC items) are assigned to groups. You therefore require an OPC group before you can insert OPC variables.

Follow the steps outlined below to create a group and add items to it:

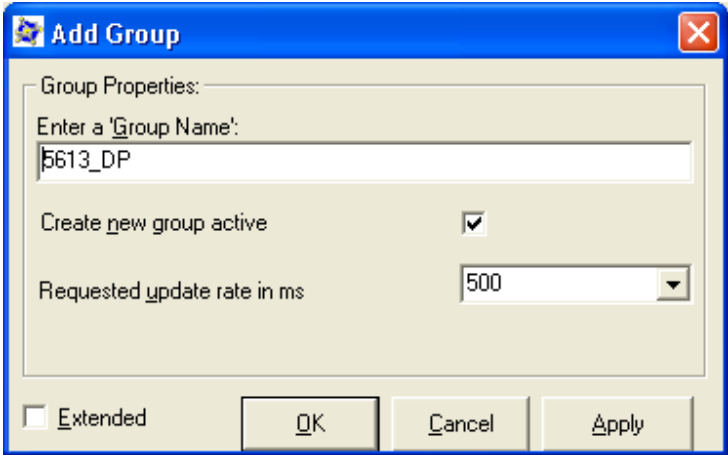
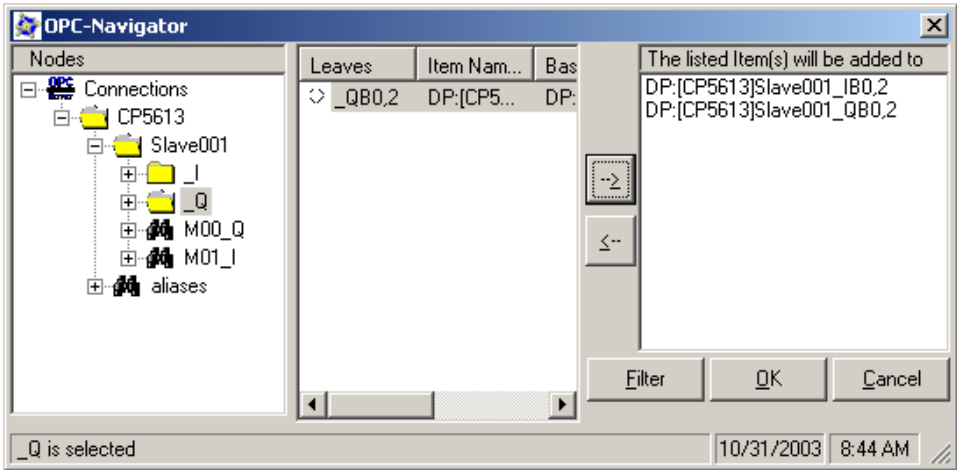
Activity	
1.	<p>After the OPC Server starts, a dialog opens in which you can create a group. Enter "5613_DP" as the group name and confirm your input with "OK":</p> 
2.	<p>Double-click on the group entry "5613_DP" to open the OPC Navigator. In the left-hand pane, you will see the hierarchically arranged name space of the OPC variables.</p>
3.	<p>If you click on an element in the tree, the OPC items defined for the element appear in the middle pane of the window:</p> 

Activity	
4.	<p>Select the following OPC items from the appropriate branches in the left-hand window and transfer these variables to the right-hand pane by clicking on the arrow button. The structure displayed and the variable names depend on the names specified in the STEP 7 program.</p> <p>DP:[CP_5613]Slave005IB0,2 DP:[CP_5613]Slave005QB0,2</p> <p>The items are added to the group after you confirm the dialog with "OK".</p>

7.5.3 Displaying and Modifying Values of Variables

Executing Synchronous and Asynchronous Write Jobs

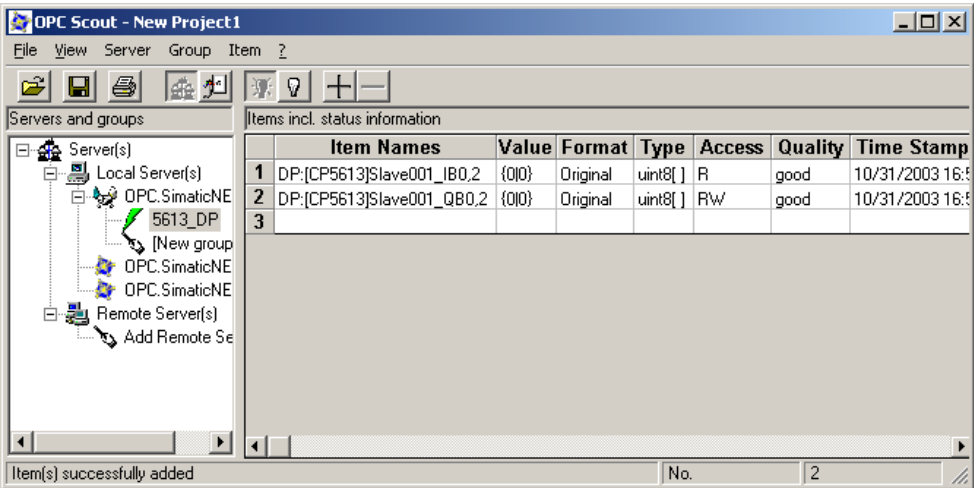
Activity	
1.	<p>The selected variables are displayed with the following additional information in the table of the main window:</p> <ul style="list-style-type: none"> ● The current value of the item ● Access Rights ● Information about the integrity of the data ● Time Stamp 
2.	<p>Now double-click on the "Value" cell of the output byte with the content {0 0} (first table row). A dialog opens in which you can change the value of a variable.</p>

Activity

3. The selected variable has an array with two elements as the data type. Arrays are shown in braces, the elements are separated by a vertical bar.
Enter {4|1} to set the output byte 0 to the value 4 and the output byte 1 to the value 1:

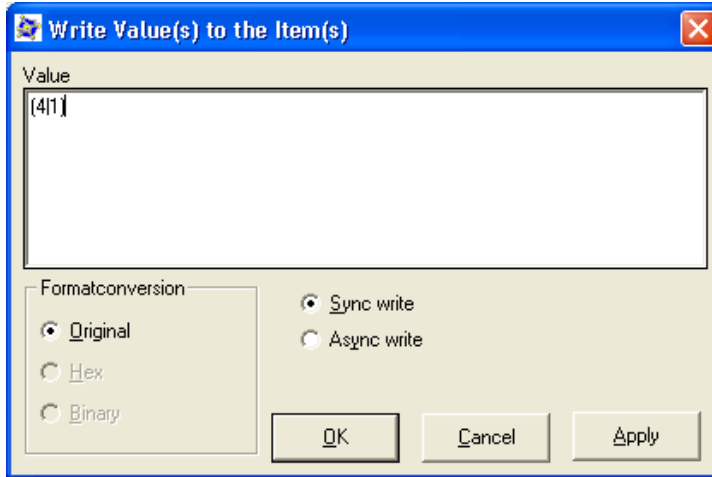

4. Click the "OK" button to start the write job.



8 Example — Unspecified Connection from a PC Application

8.1 Overview

Explanation of the Configuration Example

In this chapter you will learn how to configure and commission an S7 connection from an existing PC application with the aid of the SIMATIC NET CD 11/2003.

In the configuration example presented here, typical communication partners are connected to Industrial Ethernet and can be reached over the OPC server.

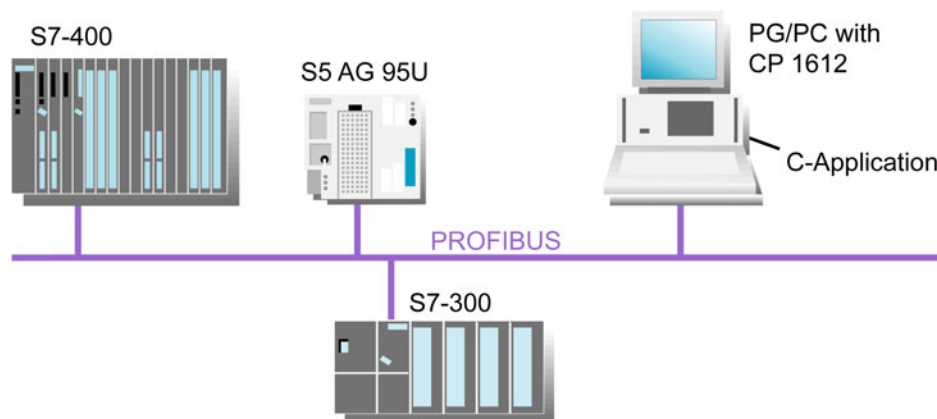

Example of an Industrial Ethernet Configuration

Communication takes place between two devices or modules. Communication with an S7-400 station using the S7 protocol with an unspecified S7 connection is described in detail below.

8.2 Installing the Software

Installing the Software



Activity	
1.	Turn on the PC and start Windows.
2.	Insert the "SIMATIC NET 11/2003" CD. If the installation program does not start the CD automatically, start the start.exe program on the CD.
3.	Follow the on-screen instructions of the installation program.

8.3 Configuring the PC Station

Overview

After starting the PC station, installing the software, and installing the hardware, the PC module of the PC station is in PG operation.

By adding the communication module in the Station Configuration Editor, the module is automatically switched to the “configured mode”.

Handling the Project Engineering Data

Depending on the case, two situations must be distinguished (see Section 2.1):

- Project engineering before initial configuration - XDB file available
- Initial configuration not dependent on project engineering

In this example, we assume that no project engineering data is available in the form of an XDB file. The initial configuration is therefore specified in the Station Configuration Editor.

You can load the initial configuration specified with the Station Configuration Editor into the project engineering system at a later point in time.



Procedure for “Initial Configuration”

1. Start the Station Configuration Editor by selecting it in the start menu (**Start ▶ Station Configuration Editor**).

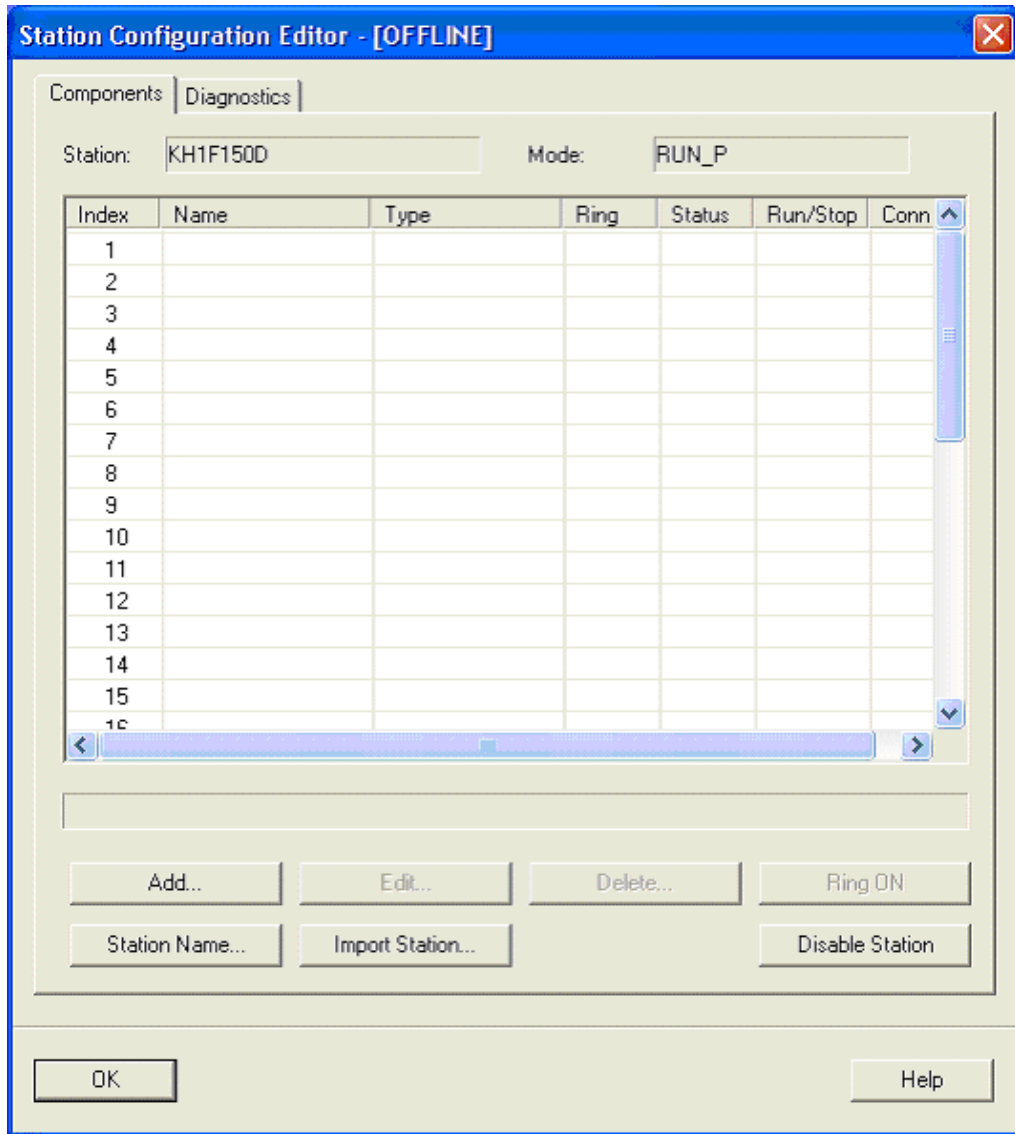

2. Select the first line and click on the “Add” button to include the application.

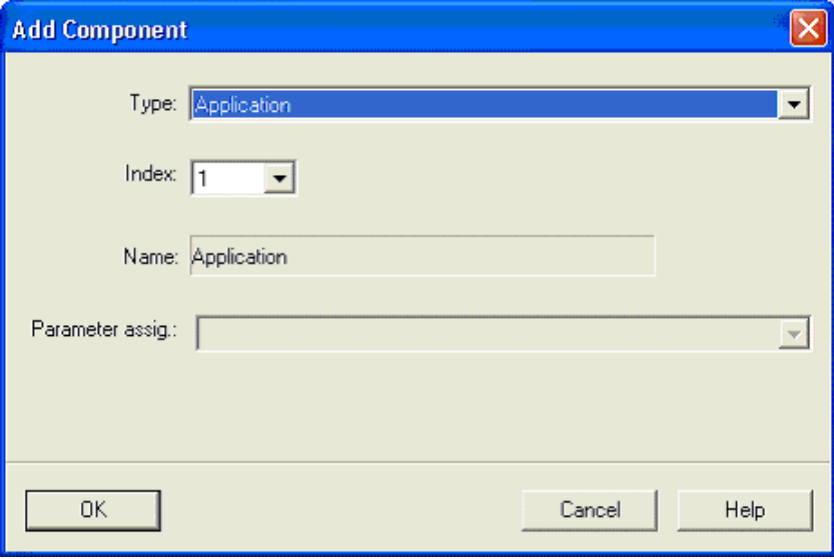
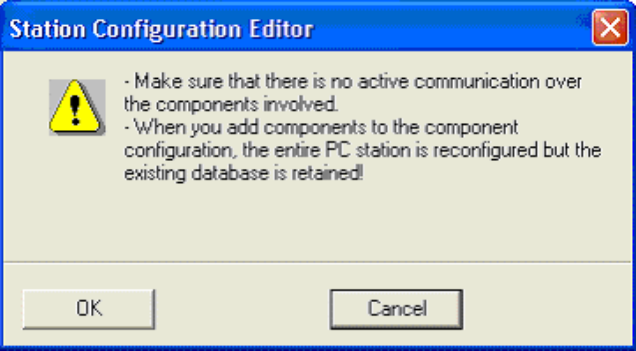
Procedure for “Initial Configuration”	
3.	 <p>Select the application in the “Type:” field and the slot in the “Index:” field. The name of the application is the VFD name in your in your C application (assigned in STEP 7; see Section 8.4.2). If you have several VFDs, you must also include several applications and assign the corresponding VFD names. If the selected index causes a conflict with the slot number configured in STEP 7 HW Config, the configuration cannot be downloaded. Confirm the dialog with “OK”.</p>
4.	 <p>Before the application can be adopted, the PC station must be restarted. Confirm the dialog with “OK”.</p>
5.	Using the “Add” button, select the CP 1612.



Procedure for “Initial Configuration”

6. Check whether the settings of the module match the local configuration.

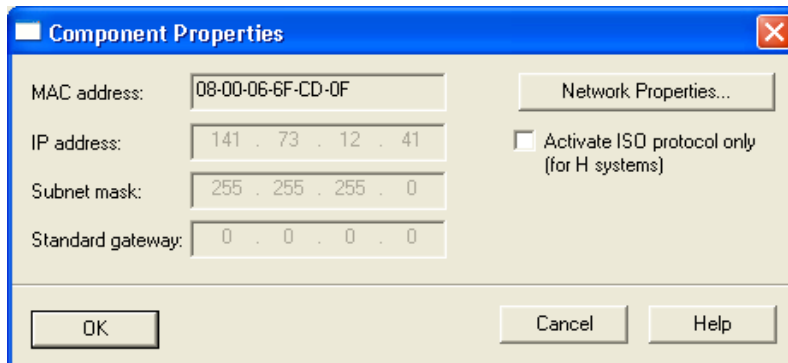

Confirm the dialog with “OK”.

- 7.

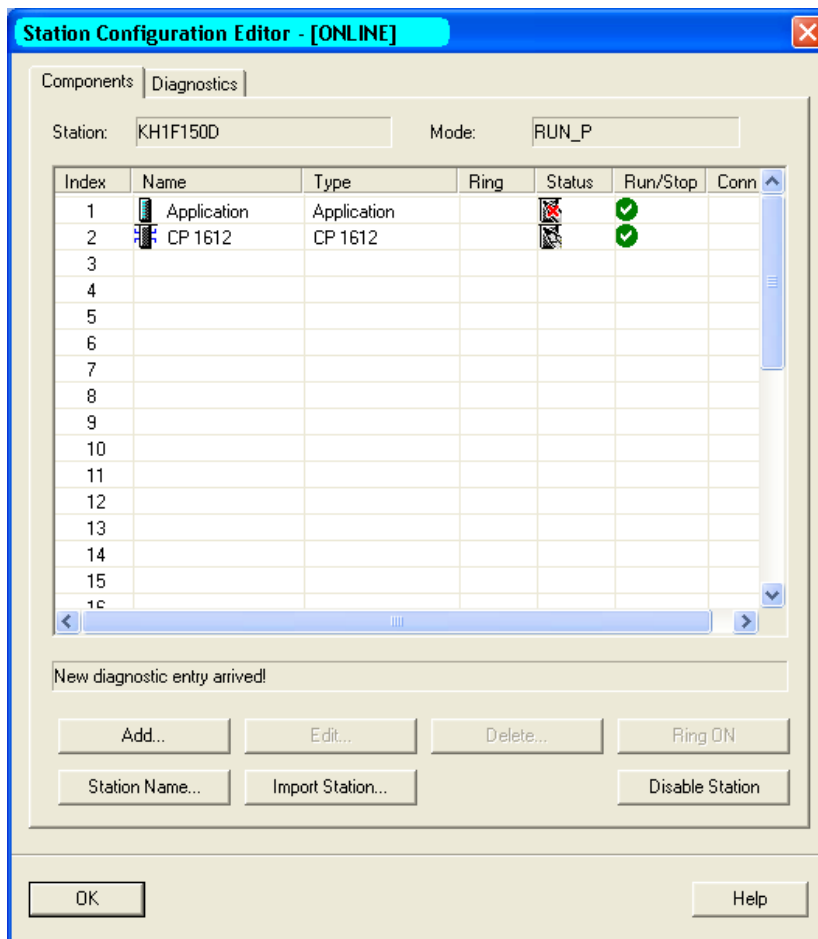

The application and the CP 1612 are inserted in the Station Configuration Editor. Confirm the dialog with “OK”.

8. Start the PC Station Wizard by double-clicking on the icon (SIMATIC NCM PC PC Station Wizard) on your desktop.



Caution

The IP addresses are read out automatically. Please note that when using DHCP, the IP addresses can change each time the computer restarts. These changes are not automatically updated in the project engineering. Here, a synchronization is necessary otherwise the configured connections will not be established and communication will not be possible.



8.4 Creating, Editing and Downloading a STEP 7 Project

Below, you will see how to create a new STEP 7 project with PC Station Wizard, add an S7 connection and download the project engineering data to the target system.

8.4.1 Creating a New Project

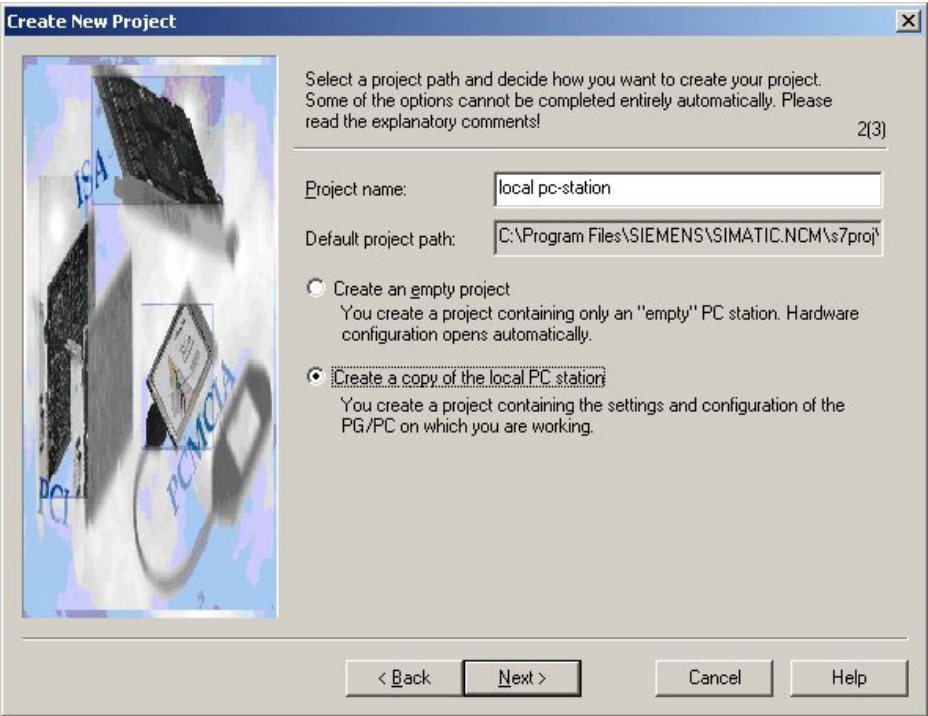
Activity	
1.	<p>The PC Station Wizard supports you when you create your STEP 7 project or when you include the PC as a PC station in an existing STEP 7 project.</p> <div style="border: 1px solid gray; padding: 5px;">  </div> <p>Select the option “Create a new project and configuration”.</p> <p>Click the “Next” button.</p> <p>Result: The “Create New Project” dialog opens.</p>

Activity

2. Create a copy of this PC as a PC station in the STEP 7 project and assign the project name (here Sample_IE). With this point, the set information is entered automatically in your project. Select “Create a copy of the local PC station”.

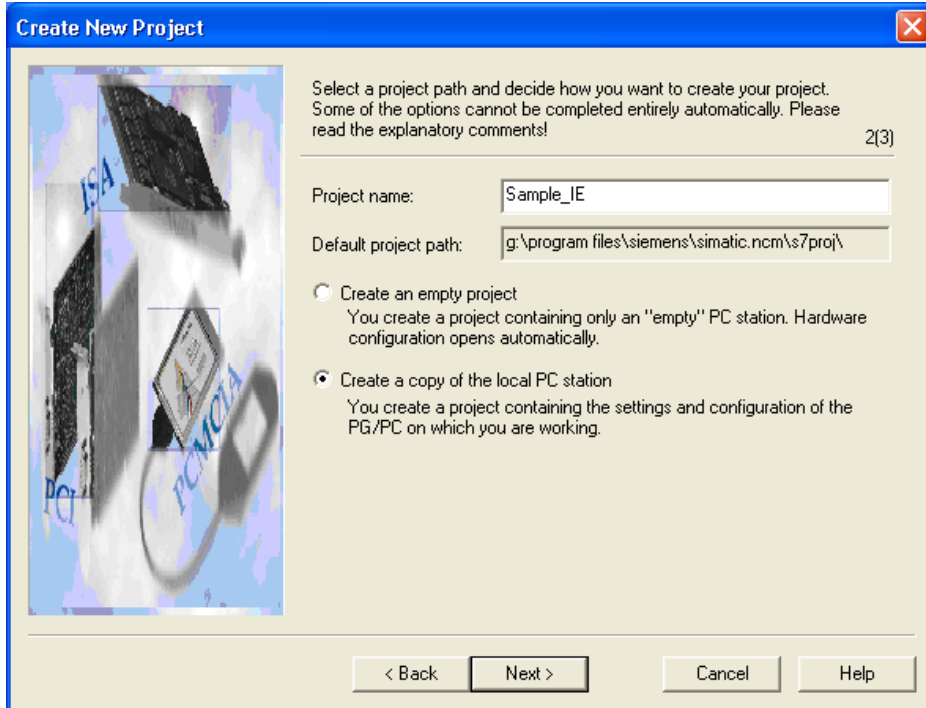

Click the “Next” button.

Result: The “Sample_IE” project is created and the “Change Settings” dialog is displayed.

8.4.2 Edit the Network and Connection Project Engineering Data

Activity

1. Select "Edit network and connection configuration".

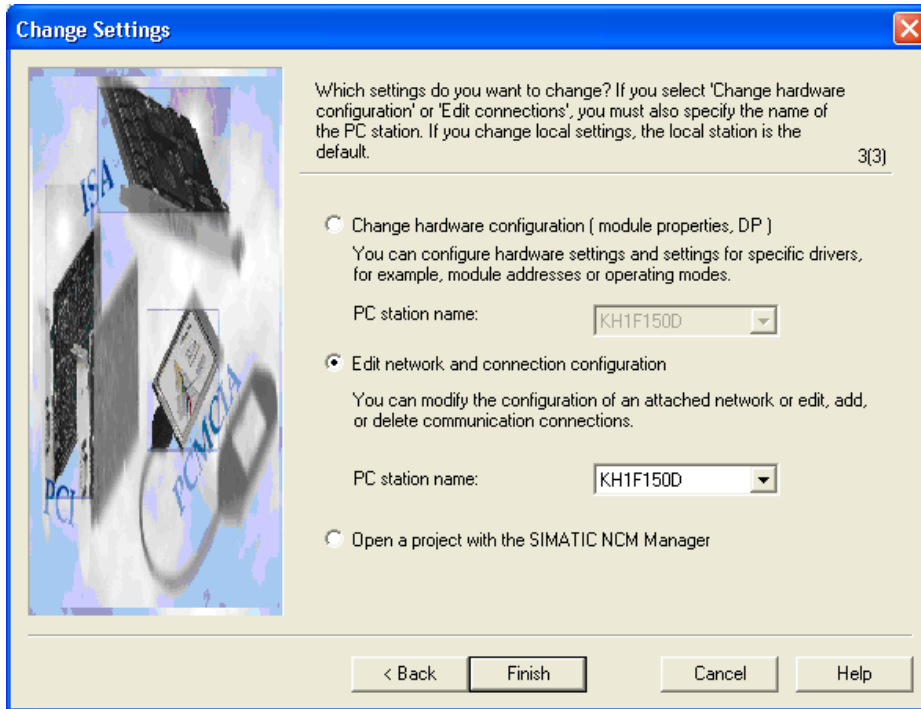

Click on the "Finish" button to start NetPro.

Activity

2. When you close the PC Station Wizard, the following menu appears.

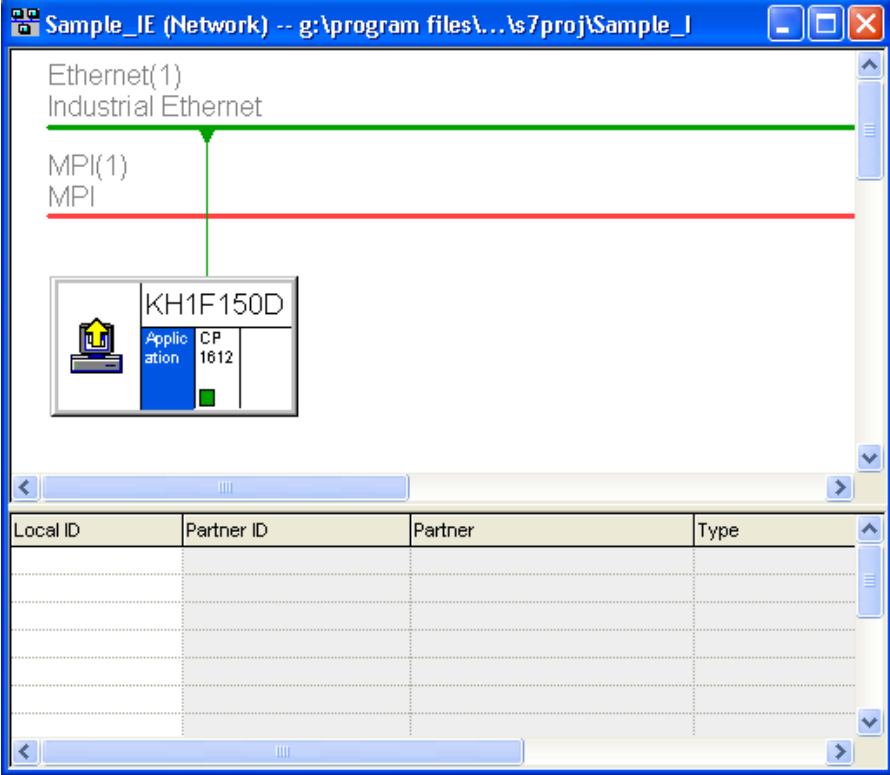

(In NetPro, you can enter the VFD name of the application (for example VFD 20) by double-clicking on application and entering the required name.

To insert a connection, you must select the application.

Select the “Application” object and the select **Insert ► New Connection**.

The following menu opens:

Activity

3.

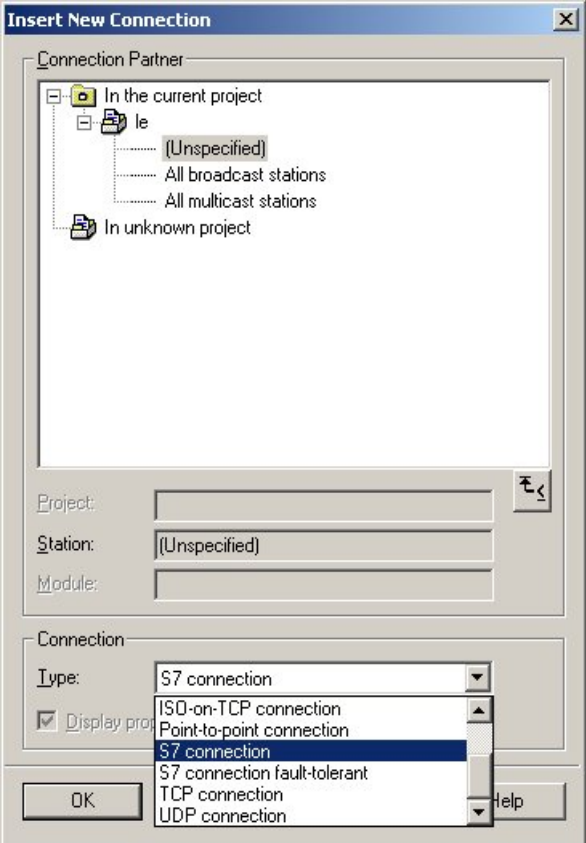

You can select the partner, however, only if it already exists in the project.

In this example, you configure an unspecified connection.

In the case of an S7 connection, no project engineering data whatsoever is required on the partner. In the connection partner for station field, select "(unspecified)". In the connection for type field, select "S7 connection".

To be able to establish the connection, the partner station must be specified by the network address and access point of the partner application (slot).

Confirm with OK.

Activity

4. When you have created a new connection, the following menu appears.

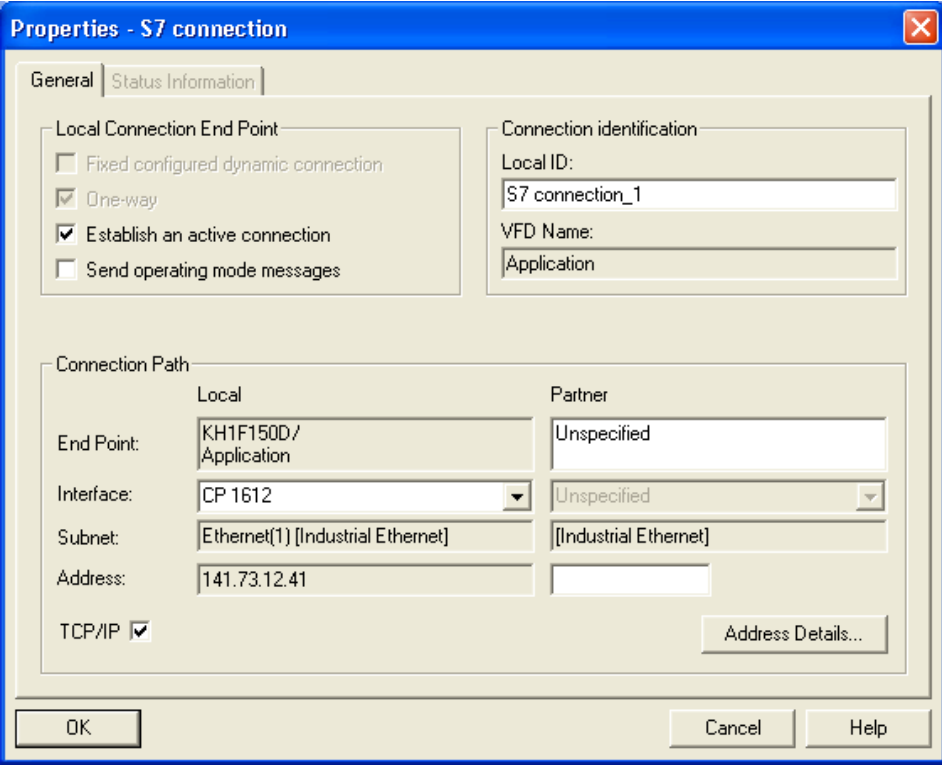

Enter the address of the partner in the field indicated.
Click the “Address Details” button to open the following menu.

Activity

5.

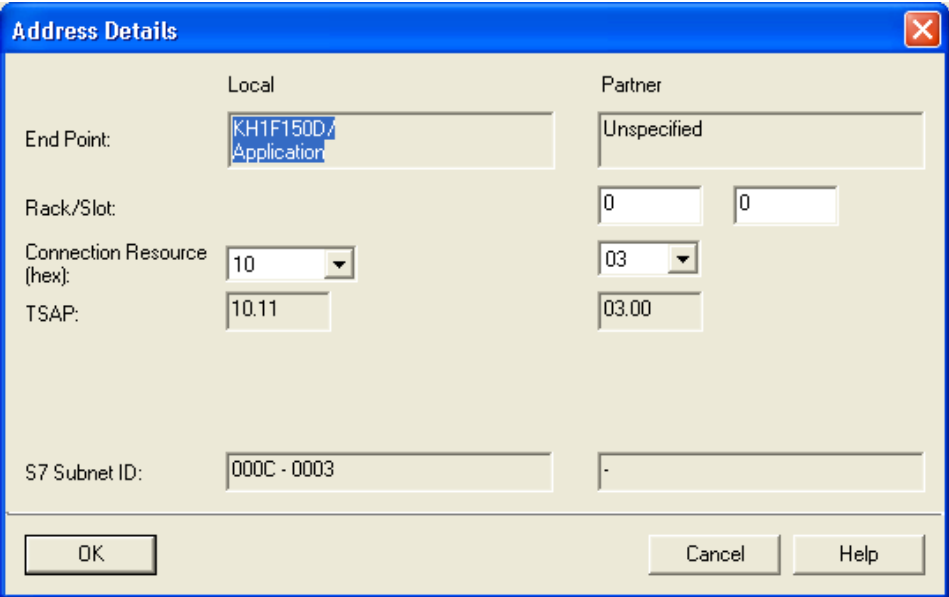

To specify the access point of the partner application, enter the slot of the CPU in the SIMATIC S7.

If you have specified the slot, click on the “OK” button.

The main menu appears again.

Once again, confirm with “OK”.

6.

When you have configured the new connection, the following menu appears.

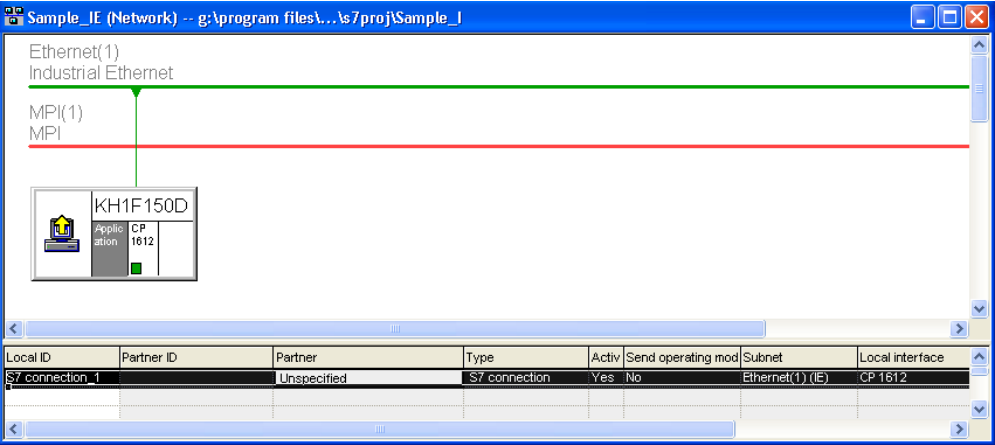

Local ID	Partner ID	Partner	Type	Activ	Send operating mod	Subnet	Local interface
S7_connection_1		Unspecified	S7_connection	Yes	No	Ethernet(1).(IE)	CP 1612

Configuration of the connection is now completed.

Save and compile the project now with the menu command “**Network ► Save and Compile**”. This updates the information in the project.

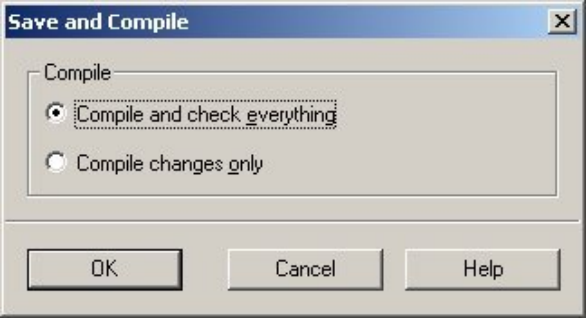
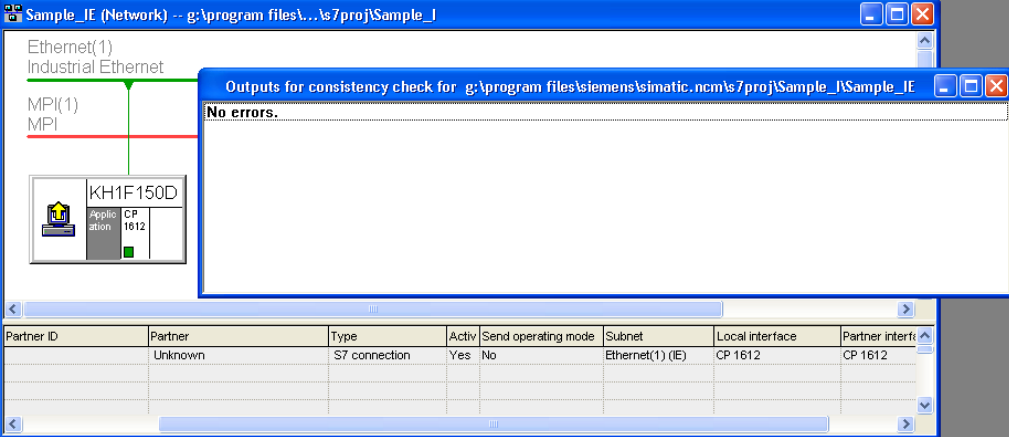
Activity																	
7.	 <p>Confirm with OK. You might be informed of errors by the consistency check.</p>																
8.	 <p>You can only download the project when it is free of errors. If you receive a warning, this is only for your information. You can close the window and download to the PC station.</p> <table border="1" data-bbox="347 1048 1289 1160"> <thead> <tr> <th>Partner ID</th> <th>Partner</th> <th>Type</th> <th>Activ</th> <th>Send operating mode</th> <th>Subnet</th> <th>Local interface</th> <th>Partner interf</th> </tr> </thead> <tbody> <tr> <td></td> <td>Unknown</td> <td>S7 connection</td> <td>Yes</td> <td>No</td> <td>Ethernet(1) (IE)</td> <td>CP 1612</td> <td>CP 1612</td> </tr> </tbody> </table>	Partner ID	Partner	Type	Activ	Send operating mode	Subnet	Local interface	Partner interf		Unknown	S7 connection	Yes	No	Ethernet(1) (IE)	CP 1612	CP 1612
Partner ID	Partner	Type	Activ	Send operating mode	Subnet	Local interface	Partner interf										
	Unknown	S7 connection	Yes	No	Ethernet(1) (IE)	CP 1612	CP 1612										



8.4.3 Downloading the Project Engineering Configuration

Activity					
1.	<p>With “PLC ► Download to Current Project ► Selected Stations”, the project engineering data is loaded locally in the Station Manager on your PC.</p> <div data-bbox="344 474 1107 741" style="border: 1px solid gray; padding: 5px;"> <p>PLC Download to current project Selected Stations (2263:35)</p> <p> This action will overwrite the configuration data that are already on the PLC(s). Do you still want to download?</p> <p style="text-align: center;"> <input type="button" value="Yes"/> <input type="button" value="No"/> <input type="button" value="Help"/> </p> </div> <p>Loading deletes the existing data on the relevant component and overwrites it with the new information. Confirm with “Yes”. The following message is displayed.</p>				
2.	<div data-bbox="344 927 1050 1451" style="border: 1px solid gray; padding: 5px;"> <p>Stop Target Modules ✖</p> <p>The following modules will be stopped for loading of the system data.</p> <table border="1" style="width: 100%; border-collapse: collapse;"> <thead> <tr> <th style="text-align: left;">Module</th> <th style="text-align: left;">Index</th> </tr> </thead> <tbody> <tr> <td>CP 1612</td> <td>2</td> </tr> </tbody> </table> <p style="text-align: center;"> <input type="button" value="OK"/> <input type="button" value="Cancel"/> <input type="button" value="Help"/> </p> </div> <p>Confirm with “OK” to complete the loading and to start the module.</p>	Module	Index	CP 1612	2
Module	Index				
CP 1612	2				

Activity

3. Open the Station Configuration Editor - the following configuration screen opens.

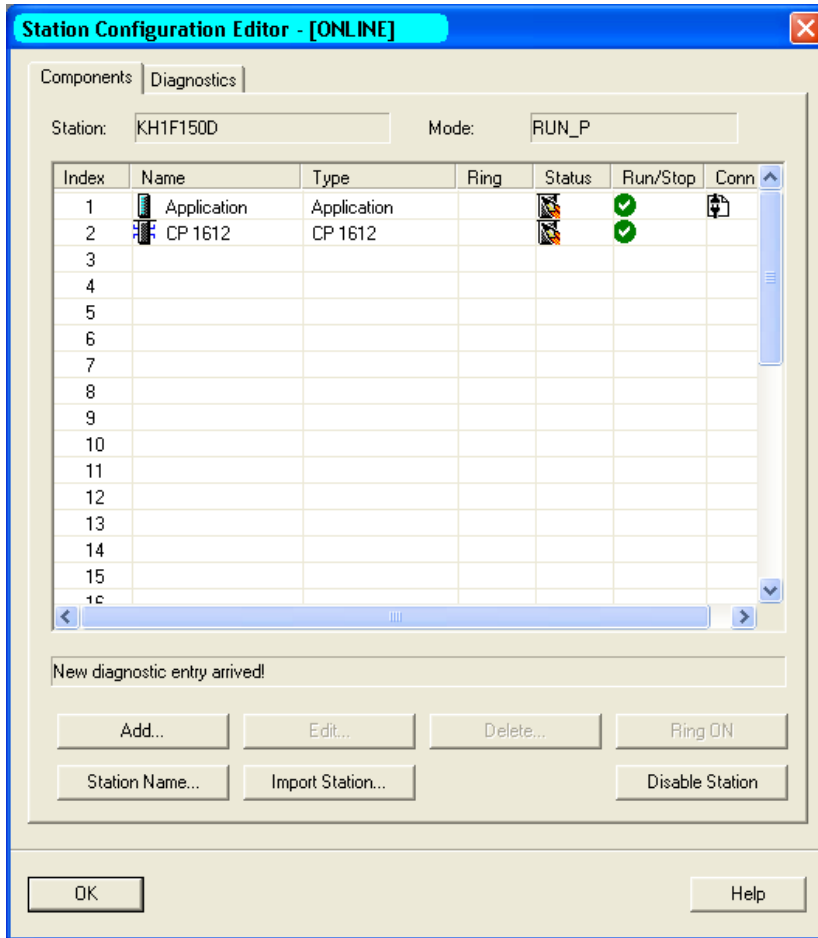

The application and the CP 1612 are inserted in the Station Configuration Editor. Confirm the dialog with "OK".

8.5 Configuration Console

The “Configuration Console” makes all local settings and diagnostic functions possible. You also have the settings or diagnostic results of the PC modules (for example CP 1612) and of the applications (for example the OPC Server) at a glance.

Configuration Console

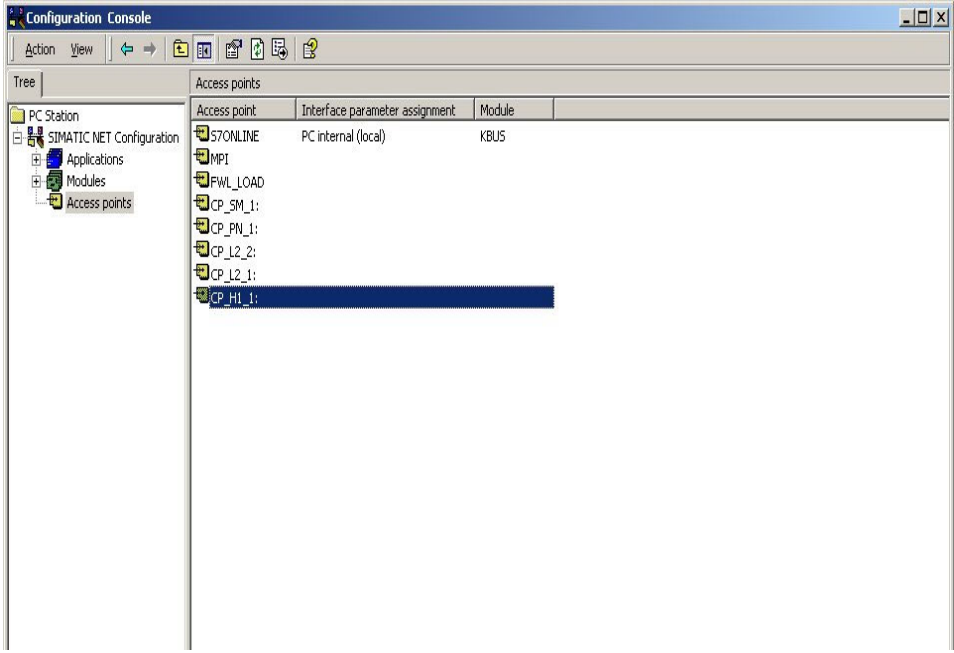
Activity	
1.	<p>Start the Configuration Console with “Start ► SIMATIC ► SIMATIC NET ► Settings ► Configuration Console”. The project engineering data is loaded locally in the Station Manager on your PC.</p> <p>Select the required “access point”.</p> 
2.	<p>By double-clicking on the selected access point, a window opens in which you can assign the module.</p> <p>If you have not used a standard access point and do not want to modify your application, you must add your access point yourself “right-click ► New ► New Access Point”. You can now specify your access point and select it.</p>

Activity

3.

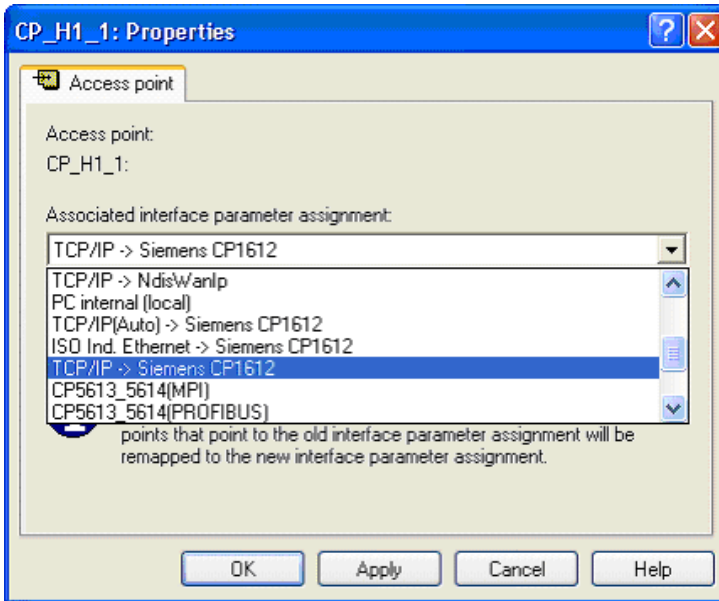

Select your module under “Assigned interface parameter assignment”.
Confirm with “OK”.

4.

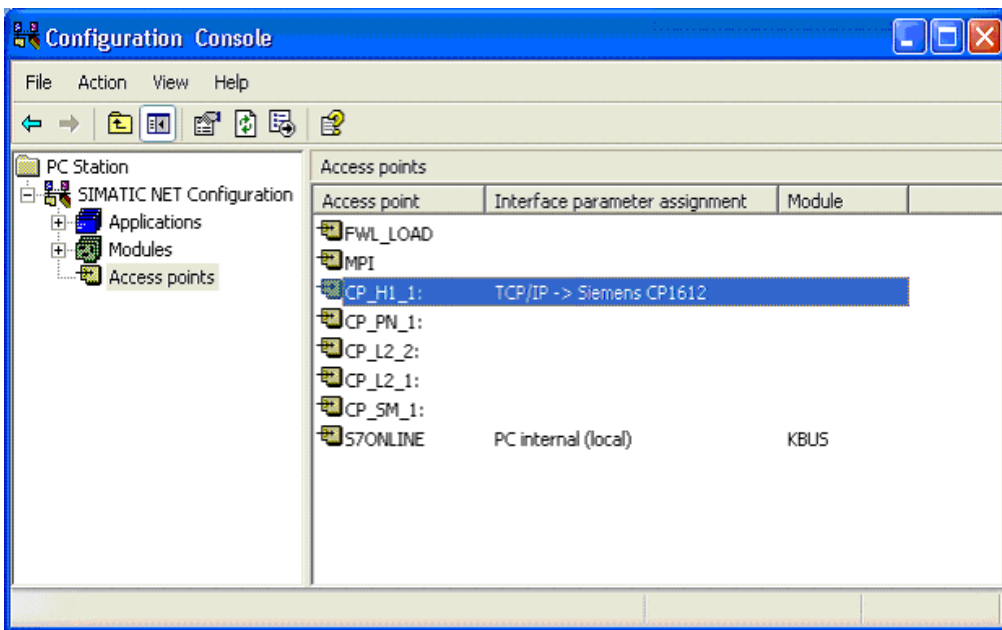

The setting is entered in the tools.
When you now start your application, it functions without changes in the source code.



9 Example — SNMP Communication with OPC

Introduction

This section describes how you link network components and nodes with an SNMP agent to a PC station over an OPC SNMP server. You will learn which tools to use to configure a PC station to implement the interfacing of a device with SNMP capability and how make the SNMP variables and SNMP traps available on the OPC interface.

You will find information about the SNMP OPC server on the Web at:

<http://www.siemens.com/snmp-opc-server>

Initial Situation

If you want to try out the example yourself, you require the following:

- a PC
- a network adapter
- the SIMATIC NET CD 11/2003 software
- a device with SNMP capability (for example SIMATIC NET OSM/ESM)
- a network connection between the OPC SNMP server and the device with SNMP capability

For the PC station, you require a STEP 7 project that was created on a central ES station (not this PC station). This should contain the hardware configuration.

9.1 Hardware and Software Installation

Installing the Software

Activity	
1.	Turn on the PC and start Windows.
2.	Insert the SIMATIC NET 11/2003 CD. If the installation program does not start the CD automatically, start the start.exe program on the CD.
3.	Follow the on-screen instructions of the installation program. Install the SIMATIC NET PC software and SIMATIC NCM PC.

Installing the Network Adapter

Activity	
1.	Shut down the PC and turn it off.
2.	Disconnect the power cable.
3.	Read the instructions for installing cards in the manufacturer's instructions for your PC.
4.	Follow the installation instructions for your network adapter and install it.
5.	Close the PC casing again as described in the instructions of your PC manufacturer and then insert the network cable.

Attaching to the Network

Activity	
1.	Connect the network cable to your network adapter.
2.	Connect the SNMP-compliant device to the network cable.
3.	Assign an IP address to the SNMP-compliant device using a device-specific or vendor-specific project engineering tool.

9.2 Configuration of the SNMP OPC Server

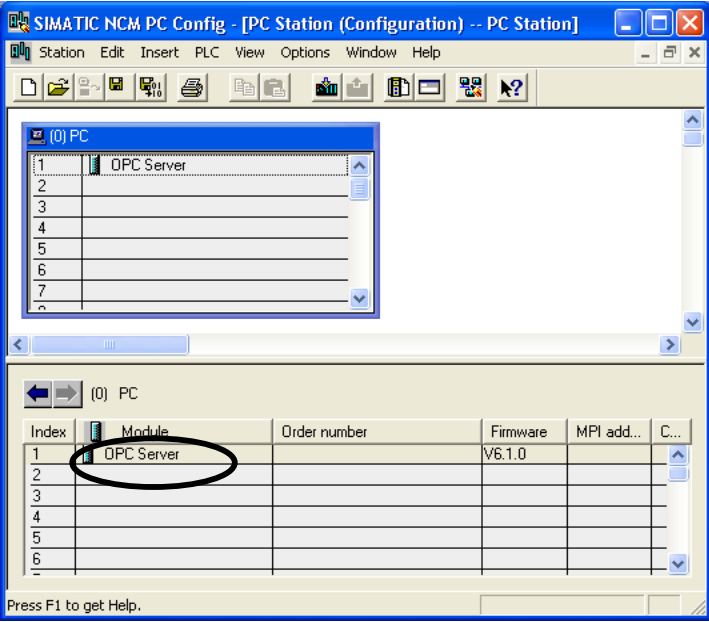
Activity	
1.	<p>Start “SIMATIC NCM PC Config” with Start ▶ SIMATIC ▶ SIMATIC NCM PC Manager and then double-click on the configuration icon.</p> <p>Double-click on the “OPC Server” field in the section “(0) PC” to configure the OPC Server:</p>  <p>Result: The “Properties - OPC Server” dialog box opens.</p>

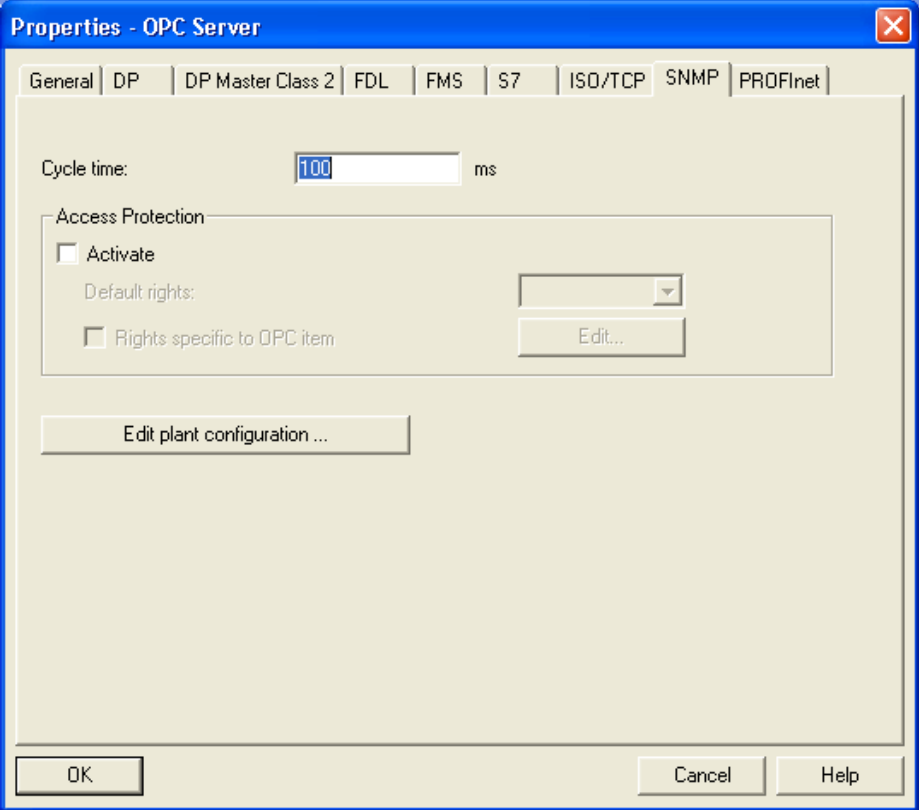
Activity	
2.	<p>Select the “SNMP” tab.</p> <p>Change the cycle time if necessary. The cycle time is the minimum time in which the variables of the OPC SNMP Server are polled.</p> <p>For more detailed information on the cycle time, refer to the online help available with the “Help” button.</p> 
3.	<p>Click on “Edit plant configuration”.</p> <p>Result: A dialog box appears in which all the devices registered with the OPC Server are listed.</p>



9.2.1 Editing the Plant Configuration

Activity

1. In this case, no devices have been registered yet.
Click on the “Add ...” button to make a new node known in the plant configuration of the OPC Server:

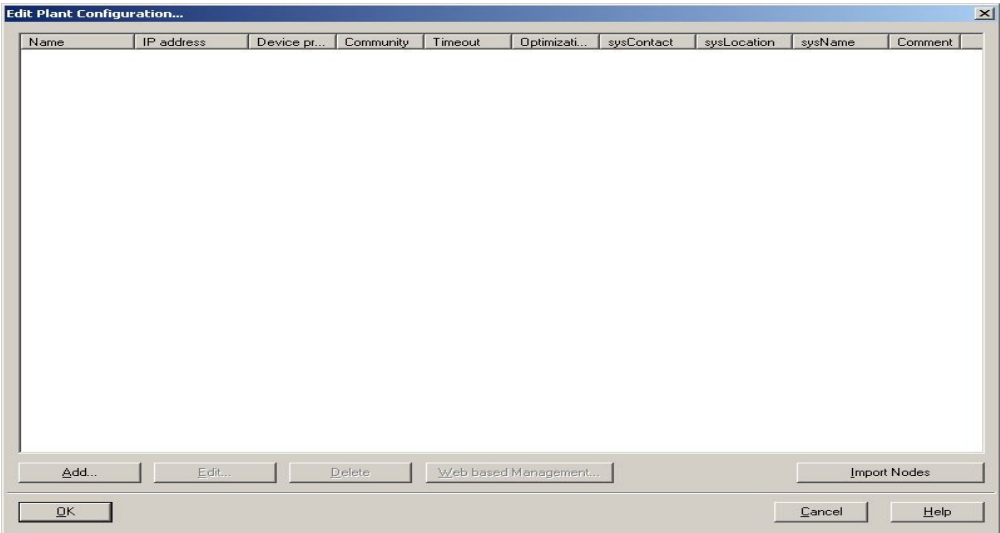

Name	IP address	Device pr...	Community	Timeout	Optimizati...	sysContact	sysLocation	sysName	Comment
------	------------	--------------	-----------	---------	---------------	------------	-------------	---------	---------

Buttons: Add..., Edit..., Delete, Web based Management..., Import Nodes, OK, Cancel, Help

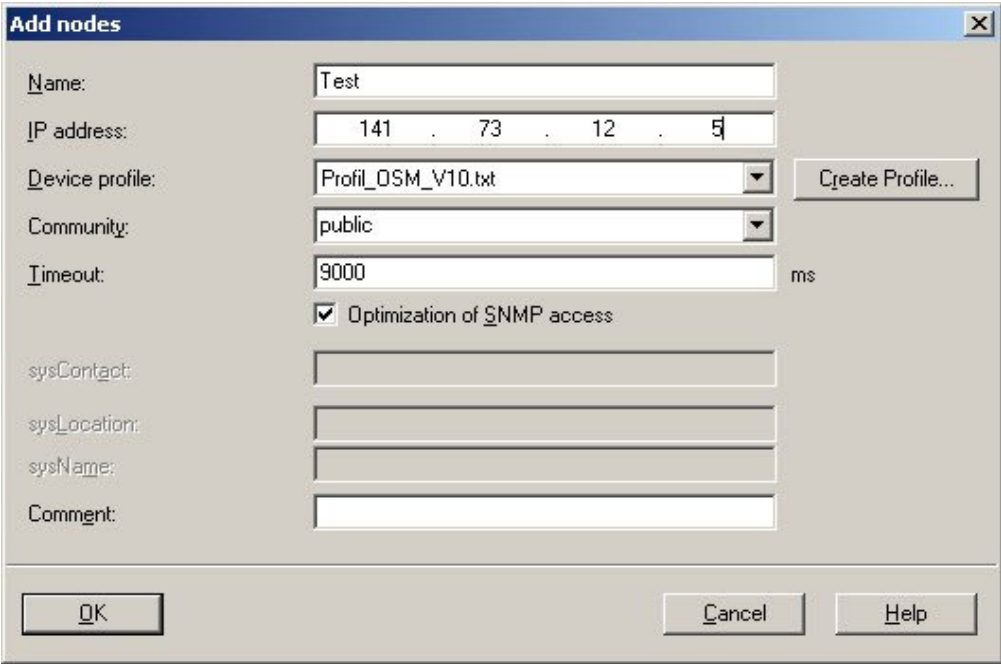
Activity	
2.	<p>Enter the necessary information for your device in the “Add Nodes” dialog box:</p> <ul style="list-style-type: none"> ● Enter a node name in the “Name” field. ● Enter the IP address of the device. ● Select a device profile. The device profile describes the mapping of SNMP variables and traps to the OPC interface. You can also create your own profiles from MIB files (see below, “Generating a Profile”). You open the relevant dialog box when you click on the “Create Profile ...” button. ● Devices without SNMP capability can also be entered to allow uniformity. For these devices, a “PING” is mapped on a sign-of-life variable. ● Enter an “SNMP Community” for the device. This decides whether or not read access only or write access is permitted with the device. ● As a comment, you can enter a text with a maximum of 255 characters <p><u>Note:</u> The fields <i>sysLocation</i>, <i>sysContact</i> and <i>sysName</i> are deactivated for devices that are not SNMP-compatible because these parameters are specified during device project engineering and can be queried on the devices.</p> 
3.	Confirm your entries by clicking on “OK”.

Activity

4. The settings are then visible in the window of the plant configuration.
 With “Import Nodes”, all devices that have an IP address and exist in the current project are included automatically in the list of the plant configuration. If the device supports Web based management, this can be started with the “Web based Management ...” button (make sure your browser settings are suitable).

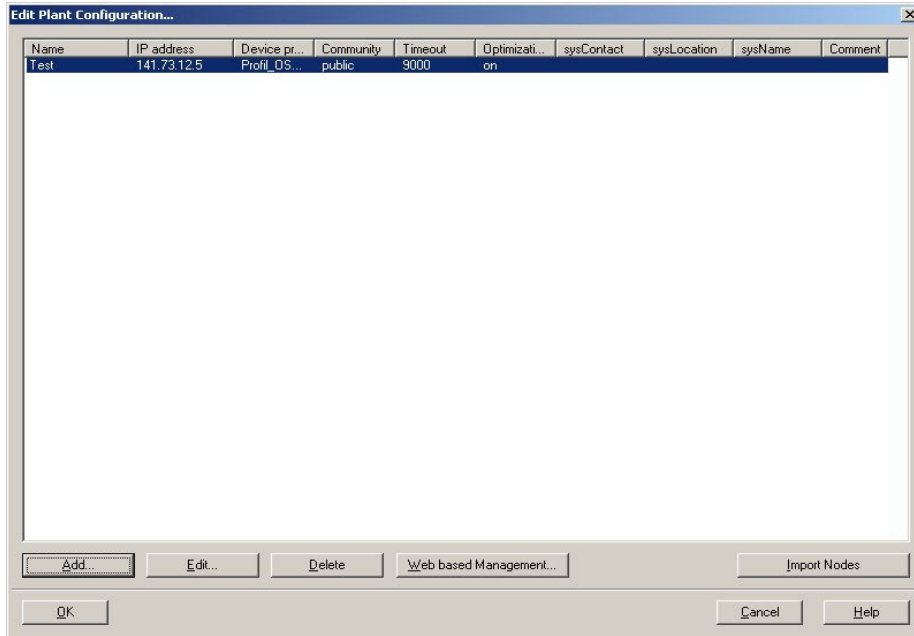

5. Click on “OK” to close the plant configuration window.
6. Click on “OK” again in the dialog box for the properties of the OPC Server to complete configuration of the SNMP OPC Server.
7. Select the NCM PC menu and then the menu item “**Station ► Save and Compile**”.
8. Select the NCM PC menu and then the menu item “**PLC ► Download to Module**”. The configuration data are downloaded to the OPC Server.
9. The OPC Server starts with the new configuration data.
 Confirm the next window with “OK”.



9.3 Configuring the PC Station

Overview

After starting the PC station, installing the software, and installing the hardware, the PC module of the PC station is in PG operation.

Handling the Project Engineering Data

Depending on the case, two situations must be distinguished (see Section 2.1):

- Project engineering before initial configuration - XDB file available
- Initial configuration not dependent on project engineering

In this example, we assume that the project engineering data is available in the form of an XDB file that was created on an external engineering station. The XDB file is transferred to the local PC station on a data storage medium. The initial configuration is then done with "Import station" (XDB import) in the Station Configuration Editor.

To allow the information from the project engineering to be transferred from the engineering system to the PC station, the local configuration must match the configuration data entered in the project engineering.

Procedure for “Initial Configuration”

1. Start the Station Configuration Editor by selecting it in the start menu (**Start ▶ Station Configuration Editor**).

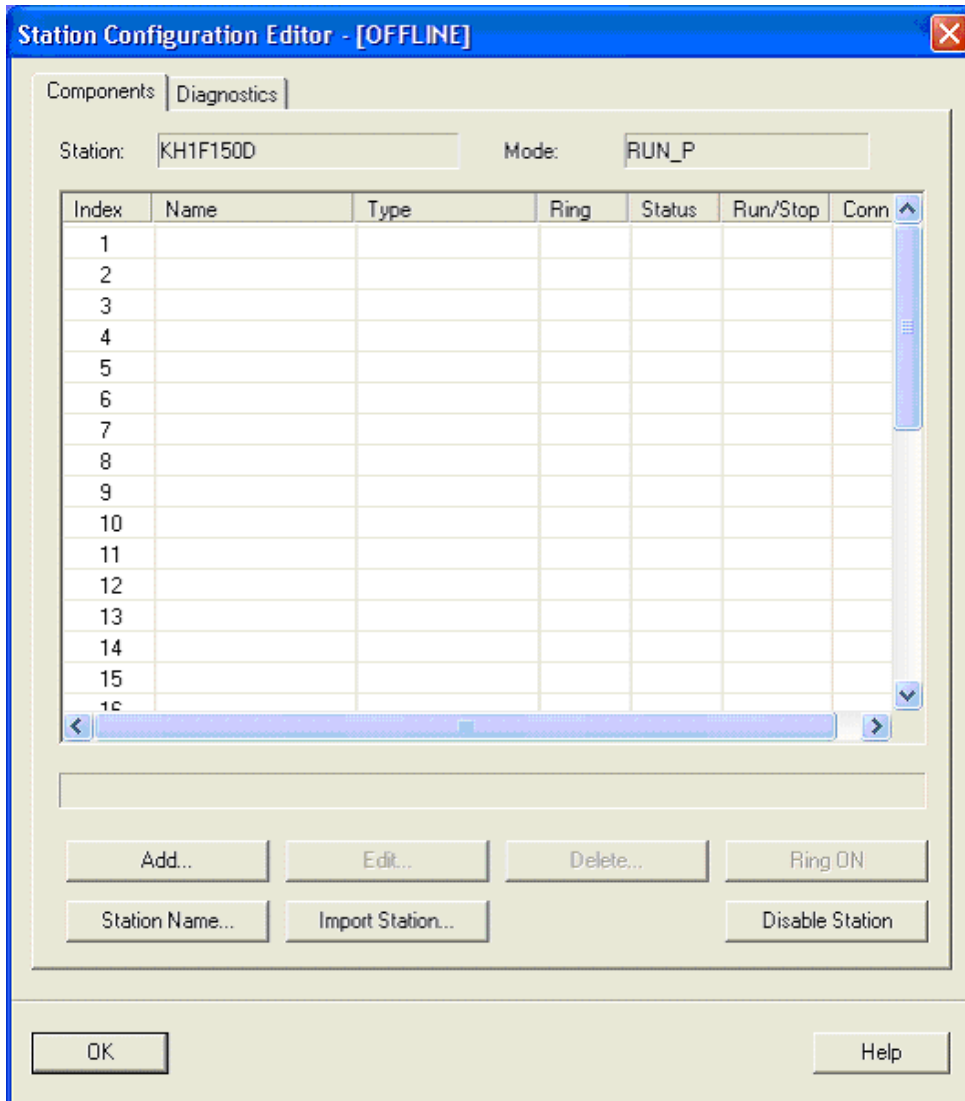

2. Click the “Import Station” button, select the XDB file that you want to import and confirm the dialog with “OK”.
3. Check whether the settings of the module match the local configuration.

Procedure for “Initial Configuration”

4. Confirm the configuration with “OK”.
 Result: All the communication data configured with S7 is now on the PC station. The communication module is in the “configured mode”.
 PC configuration is complete.

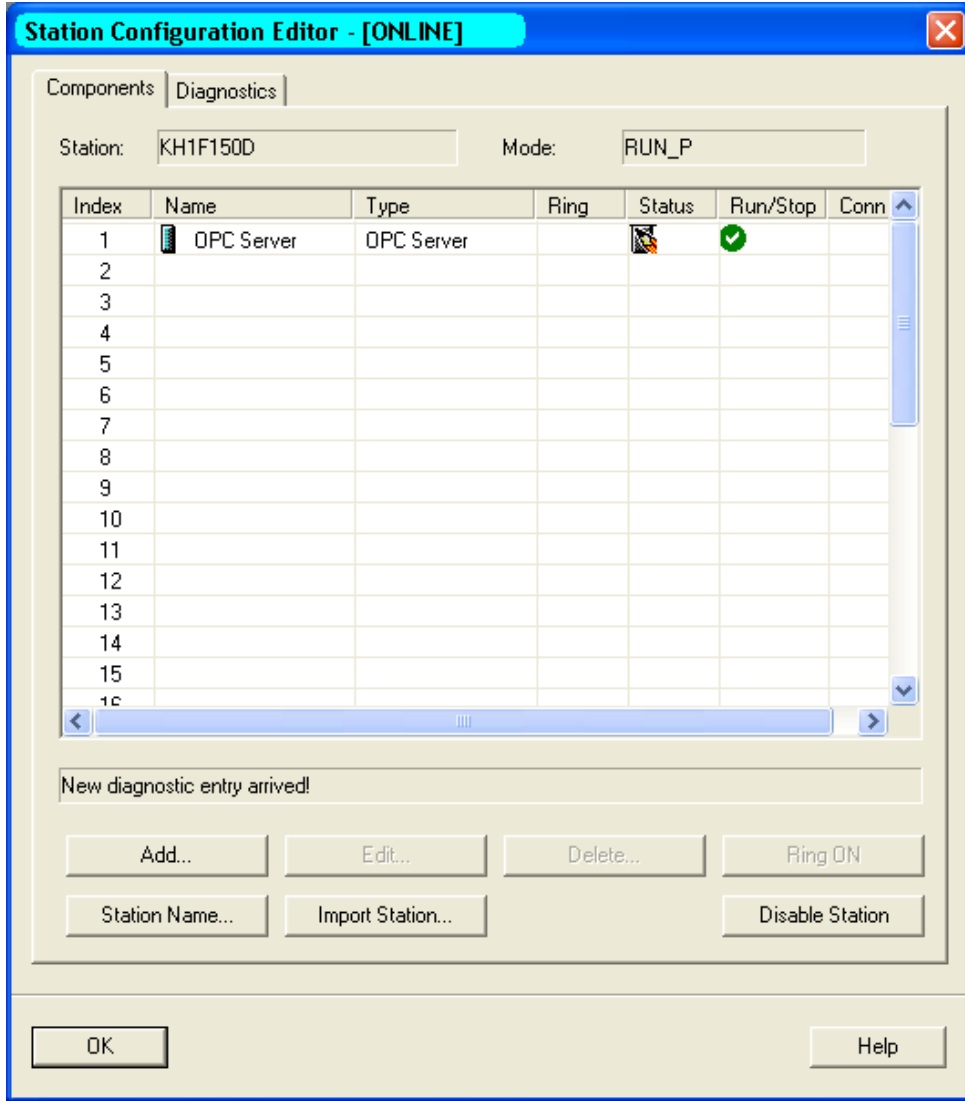

9.4 Using the OPC Scout

The OPC Scout as Client for Commissioning and Testing

You can now access the objects of the programmable controller with any OPC client. The OPC Scout is supplied with the SIMATIC NET PC Software as a tool for commissioning and testing. The next section describes how to read and write variables with this program.

9.4.1 Establishing a Connection to the Server

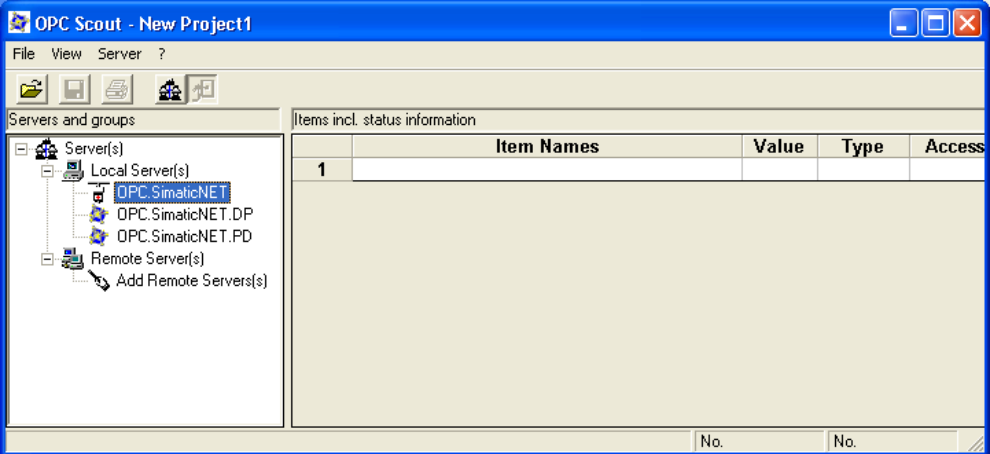
Activity	
1.	Start the OPC Scout program.
2.	<p>Double-click the “OPC.SimaticNET” entry to link the OPC Scout with the OPC Server.</p> 
3.	The “Add Group” dialog box opens.

9.4.2 Inserting a Group

Organizing Process Variables

The process variables of the OPC server (known as OPC items) are assigned to groups. You therefore require an OPC group before you can insert OPC variables. Follow the steps outlined below to create a group and add items to it:

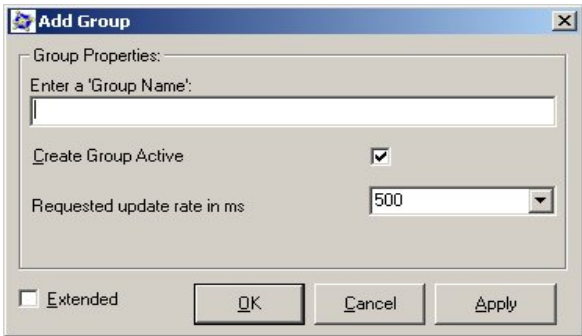
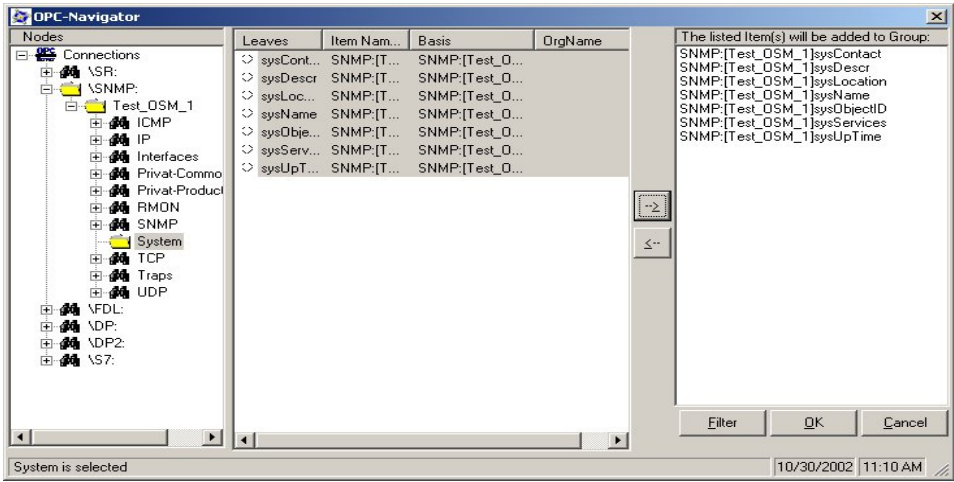
Activity	
1.	<p>Enter a group name in the “Add group” dialog box and confirm the window with “OK”. If you do not enter a group name, the OPC Server specifies a group name automatically:</p> 
2.	<p>In the left-hand window of the OPC Scout, an entry is created for the group below the icon for the OPC Server. Double-click on this group entry to open the OPC Browser. In the left-hand pane, you will see the hierarchically arranged name space of the OPC variables.</p>
3.	<p>Click on an element of this structure tree. In the middle window, the OPC items defined for this element are displayed:</p> 
4.	<p>Select the OPC items you want to add to the group in the middle part of the window.</p>
5.	<p>Enter the selected items in the right part of the window by clicking on the arrow pointing right.</p>

Activity

6. Now click on “OK” to insert all the items listed in the right part of the window in the group.
7. The right part of the main window includes the following additional information for the items of the selected group:
 - The current value of the item.
 - Information on the access rights.
 - Information about the integrity of the data.
 - Time stamp.

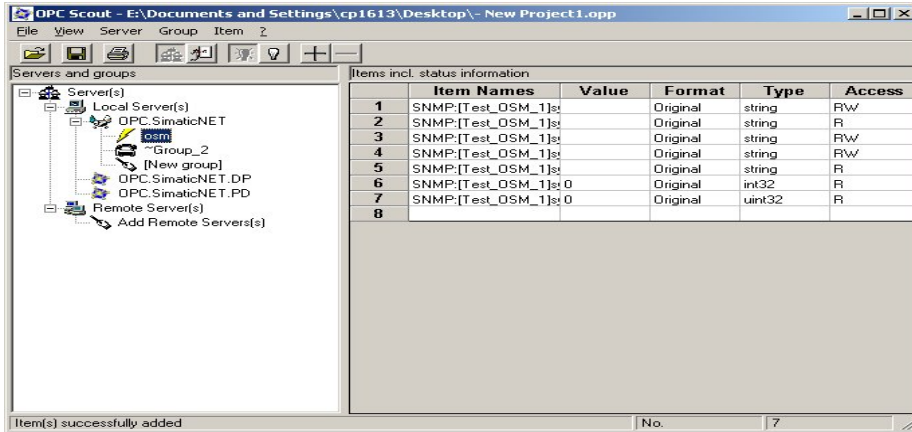

9.4.3 Setting the Trap Recipient based on the Example of an OSM/ESM

Writing Values

You set the trap recipient of an OSM/ESM by assigning suitable values to two OPC items. The procedure described here is also an example of how to write values for OPC items using the OPC Scout.

Maximum of Ten Trap Recipients

To specify the trap recipients, you use the variables *snTrapAddress* and *snTrapState*. These variables each have ten instances (*snTrapAddress1* to *snTrapAddress10* and *snTrapState1* to *snTrapState10*). On the OSM/ESM, you can therefore enter up to ten trap recipients. The device sends the trap frames to all registered recipients.

Writing Values for *snTrapAddress* and *snTrapState*

Activity																																									
1.	<p>In the left-hand window of the OPC Scout, the folder icon <i>SNMP</i> also contains a subfolder with the configured connection name. This folder contains a group with trap variables. If you use the profile supplied with the OSM, the name of this group is <i>Privat-Common</i>. If you use a newly created profile, the trap variables are in the group specified for it.</p> <p>Click on the symbol of the group with the trap variables to display a list of these variables in the mid part of the window. The variable <i>snTrapAddress</i> contains the IP address of the trap recipient, <i>snTrapState</i> specifies whether or not the entry is activated (2) or deactivated (3):</p> <table border="1"> <thead> <tr> <th colspan="8">Items incl. status information</th> </tr> <tr> <th></th> <th>Item Names</th> <th>Value</th> <th>Format</th> <th>Type</th> <th>Access</th> <th>Quality</th> <th>Time Stamp (UTC)</th> </tr> </thead> <tbody> <tr> <td>1</td> <td>SNMP:[OSM1]snTrapAddress.1</td> <td>0.0.0.0</td> <td>Original</td> <td>string</td> <td>RW</td> <td>good</td> <td>10/31/2002 06:06:49.740</td> </tr> <tr> <td>2</td> <td>SNMP:[OSM1]snTrapState.1</td> <td>3</td> <td>Original</td> <td>int32</td> <td>RW</td> <td>good</td> <td>10/31/2002 06:06:49.740</td> </tr> <tr> <td>3</td> <td></td> <td></td> <td></td> <td></td> <td></td> <td></td> <td></td> </tr> </tbody> </table>	Items incl. status information									Item Names	Value	Format	Type	Access	Quality	Time Stamp (UTC)	1	SNMP:[OSM1]snTrapAddress.1	0.0.0.0	Original	string	RW	good	10/31/2002 06:06:49.740	2	SNMP:[OSM1]snTrapState.1	3	Original	int32	RW	good	10/31/2002 06:06:49.740	3							
Items incl. status information																																									
	Item Names	Value	Format	Type	Access	Quality	Time Stamp (UTC)																																		
1	SNMP:[OSM1]snTrapAddress.1	0.0.0.0	Original	string	RW	good	10/31/2002 06:06:49.740																																		
2	SNMP:[OSM1]snTrapState.1	3	Original	int32	RW	good	10/31/2002 06:06:49.740																																		
3																																									
2.	<p>Select the <i>snTrapAddress1</i> entry and select the menu command "Write value(s)" in the context-sensitive menu. The dialog box for synchronous and asynchronous writing appears.</p>																																								

Activity

3. Enter the IP address of the trap recipient and click the “OK” button:

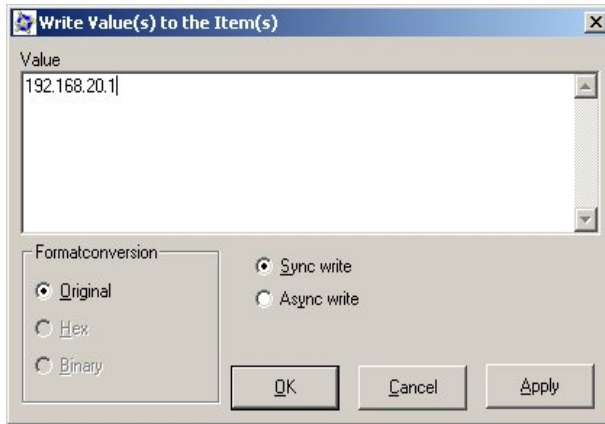

5. Select the *snTrapState1* entry and select the menu command “Write value(s)” in the context-sensitive menu. The dialog box for synchronous and asynchronous writing appears.

6. Enter “2” to activate the trap recipient and click on the “OK” button:

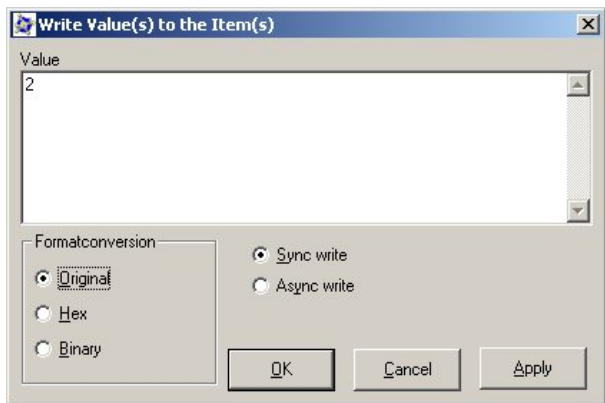

9.5 Creating a Device Profile with the MIB Compiler

Device Profile

A device profile contains the SNMP objects (OPC items) required for the SNMP interface of the OPC Server. It maps SNMP variables and SNMP traps on the OPC interface. Device profiles are stored in profile files.

MIB Files and MIB Compiler

MIB files (**M**anagement **I**nformation **B**ase) are descriptions of SNMP variables and SNMP traps in a form specified by Internet standards. There are standard MIBs specified for devices with the same functionality and device/vendor-specific MIB files.

You create a device profile with the MIB compiler from an existing MIB file.

Calling and Handling the MIB Compiler

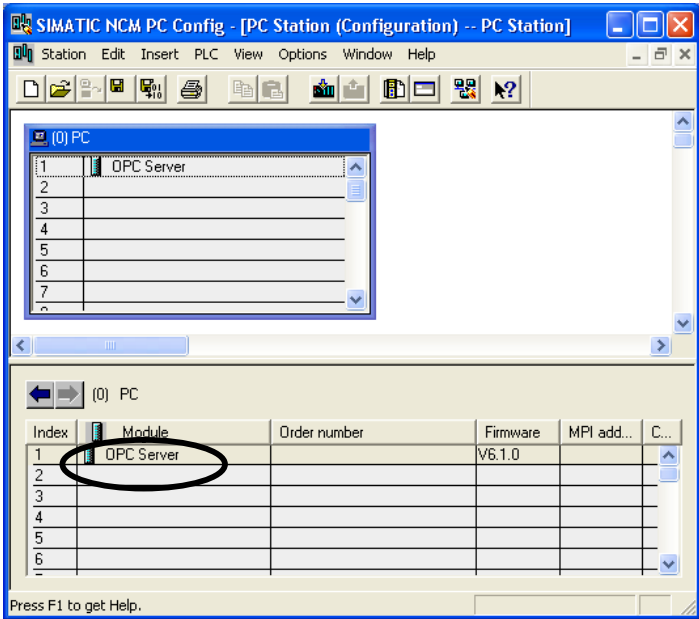
Activity																																																	
1.	<p>Start “SIMATIC NCM PC Config” with Start ▶ SIMATIC ▶ SIMATIC NCM PC Manager and then double-click on the configuration icon.</p> <p>Double-click on the “OPC Server” field in the section “(0) PC” to configure the OPC Server:</p>  <table border="1" data-bbox="344 1554 1046 1713"> <thead> <tr> <th>Index</th> <th>Module</th> <th>Order number</th> <th>Firmware</th> <th>MPI add...</th> <th>C...</th> </tr> </thead> <tbody> <tr> <td>1</td> <td>OPC Server</td> <td></td> <td>V6.1.0</td> <td></td> <td></td> </tr> <tr> <td>2</td> <td></td> <td></td> <td></td> <td></td> <td></td> </tr> <tr> <td>3</td> <td></td> <td></td> <td></td> <td></td> <td></td> </tr> <tr> <td>4</td> <td></td> <td></td> <td></td> <td></td> <td></td> </tr> <tr> <td>5</td> <td></td> <td></td> <td></td> <td></td> <td></td> </tr> <tr> <td>6</td> <td></td> <td></td> <td></td> <td></td> <td></td> </tr> <tr> <td>-</td> <td></td> <td></td> <td></td> <td></td> <td></td> </tr> </tbody> </table> <p>Result: The “Properties - OPC Server” dialog box opens.</p>	Index	Module	Order number	Firmware	MPI add...	C...	1	OPC Server		V6.1.0			2						3						4						5						6						-					
Index	Module	Order number	Firmware	MPI add...	C...																																												
1	OPC Server		V6.1.0																																														
2																																																	
3																																																	
4																																																	
5																																																	
6																																																	
-																																																	

Activity

2. Select the "SNMP" tab and click on the "Edit plant configuration ..." button:

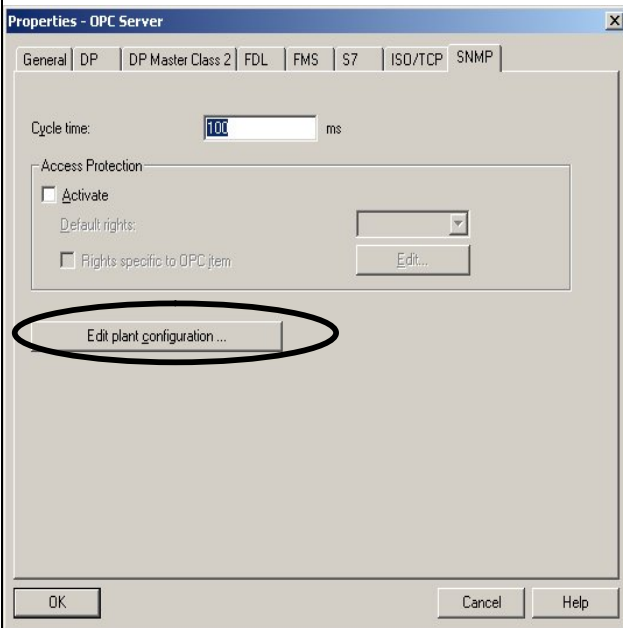

3. A dialog box appears in which all the SNMP-compliant devices registered with the OPC Server are listed. Select the device for which you want to create a profile and click the "Edit ..." button to display the dialog box with the node data of the device:

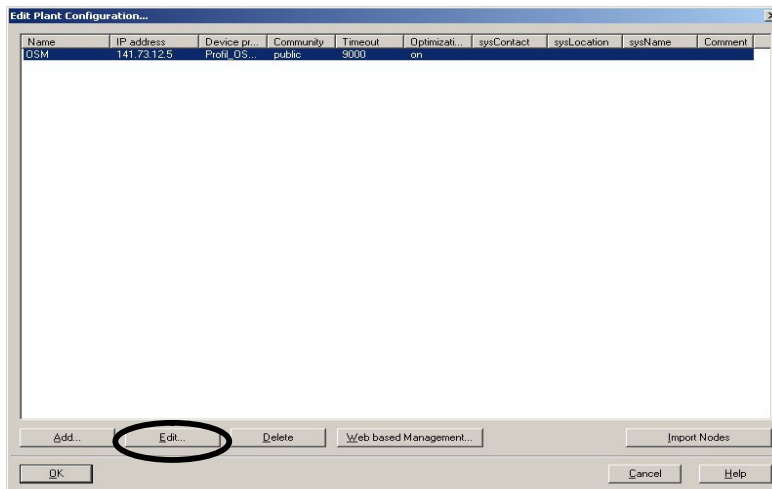

Activity

4. Click on the “Create Profile ...” button to open the dialog box of the MIB compiler:

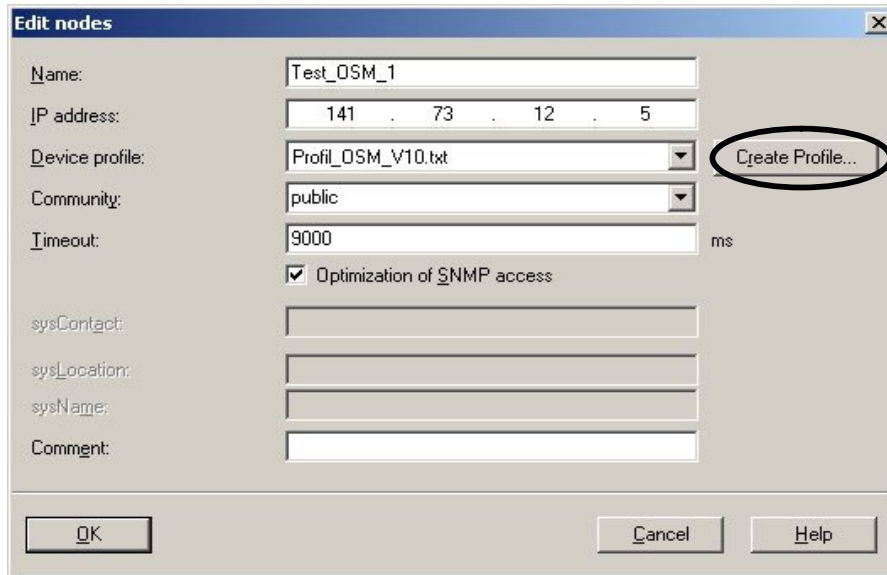

5. The dialog box of the MIB compiler is in three areas:

- Left area: MIB area for displaying the MIB objects from the loaded MIB files.
- Right area: Profile area for adopting and displaying the OPC items / OPC events.
- Lower area: Output window for compiler messages.

Click the “Load MIB...” button. Select the required MIB file in the dialog for opening a file (for example RFC1213-MIB.mib). The content of this file is shown in the left-hand area:

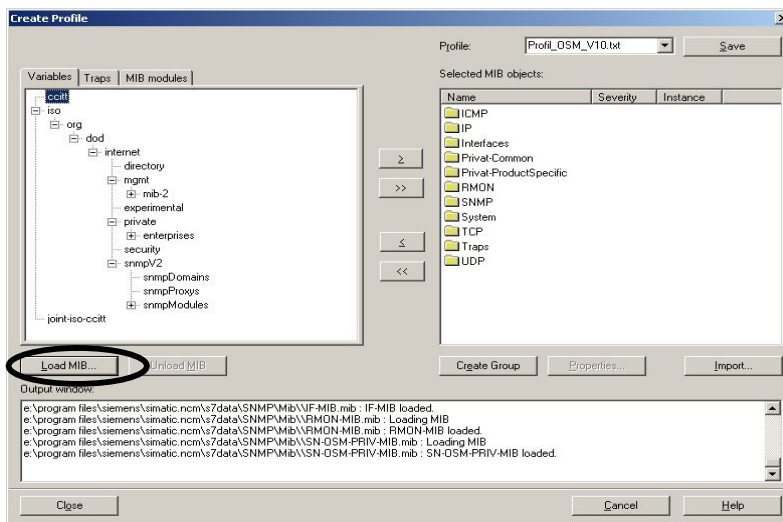



Activity	
6.	Select the MIB objects for the profile in the structure tree on the left and drag them to the profile area of the dialog box. You can also select a node and drag it to the right-hand area. In this case, all the SNMP variables belonging to the node are adopted as OPC variables.
7.	Structuring of the variables in the profile area is possible, in keeping with the OPC specification, by creating groups. To do this, click on the “Create Group” button.
8.	Check whether or not the adopted SNMP variables still include unspecified instances of variables. Such elements are indicated by a “!”. Double-click on such elements to open the “Enter Instances” dialog box. For example, for an 8-port switch, the object <i>ifOperStatus</i> must be assigned the instances 1-8 so that the OPC items <i>ifOperStatus.1</i> to <i>ifOperStatus.8</i> can be formed).
9.	Save the profile by clicking on the “Save” button. You can select the newly created profile in the “Device Profile” list box of the “Add Nodes” dialog box.

□

10 Example — PROFINet Communication with OPC

Introduction

This example illustrates how to link an S7-300 programmable controller with a PC station over a PROFINet communications processor.

You will see which tools to use for configuring a PC station and interfacing a PROFINet device. You will also see how symbolic variables of PROFINet are made available in OPC.

Initial Situation

If you want to try out the example yourself, you require the following:

- a PC
- a network adapter for Industrial Ethernet
- the SIMATIC NET CD 11/2003 software
- an S7-300 PLC with a CP 343-1 PN PROFINet communications processor
- Industrial Ethernet cabling between the PC module and S7 device

For the S7-300, you require a project created with the PROFINet tool “SIMATIC iMap”.

Creating a project engineering configuration with SIMATIC iMap is beyond the scope of this description and is not included.

10.1 Hardware and Software Installation

Installing the Network Adapter

Activity	
1.	Shut down the PC and turn it off.
2.	Disconnect the power cable.
3.	Read the instructions for installing cards in the manufacturer's instructions for your PC.
4.	Insert the network adapter in a PCI slot.
5.	Close the PC casing again as described in the instructions from your PC manufacturer and then insert the network cable.

Attaching to the Network

Activity	
1.	Connect the Ethernet cable to the network adapter.
2.	Connect the S7-300 device to the Ethernet cable.

Installing the Software

Activity	
1.	Turn on the PC and start Windows.
2.	Insert the SIMATIC NET 11/2003 CD. If the installation program does not start the CD automatically, start the Setup.exe program on the CD.
3.	Follow the on-screen instructions of the installation program.

10.2 Configuring the PC Station

Overview

After starting the PC station, installing the software, and installing the hardware, the PC module of the PC station is in PG operation.

By adding the communication module in the Station Configuration Editor, the module is automatically switched to the “configured mode”.

Handling the Project Engineering Data

Depending on the case, two situations must be distinguished (see Section 2.1):

- Project engineering before initial configuration - XDB file available
- Initial configuration not dependent on project engineering

In this example, we assume that project engineering data is available in the form of an XDB file. The initial configuration is therefore imported in the Station Configuration Editor.

To allow the information from the project engineering to be transferred from the engineering system to the PC station, the local configuration must match the configuration data entered in the project engineering.



Procedure for “Initial Configuration”

1. Start the Station Configuration Editor by selecting it in the start menu (**Start ▶ Station Configuration Editor**).

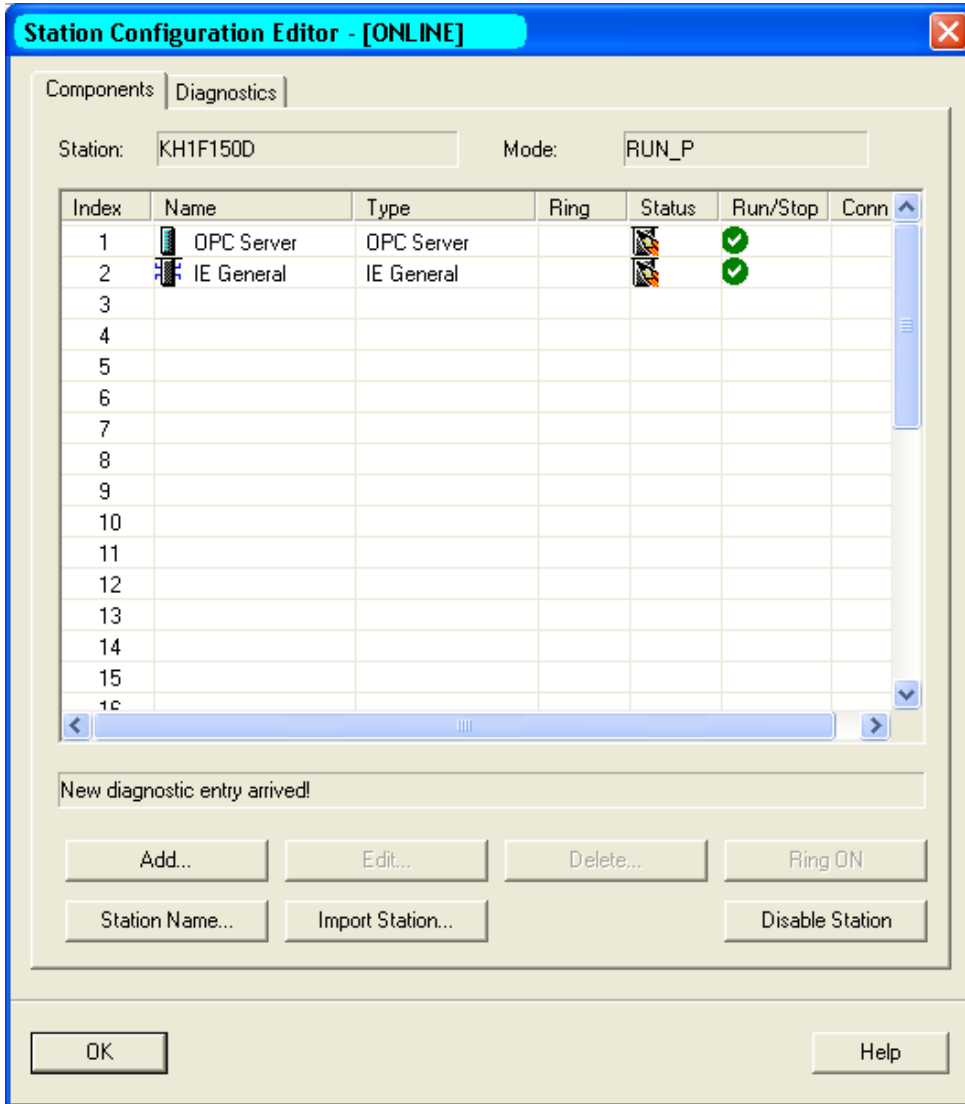

2. Click the “Import Station” button, select the XDB file that you want to import and confirm the dialog with “OK”.
3. Check whether the settings of the module match the local configuration.

Note

To operate PROFINet, no STEP 7 project engineering data is necessary on the PC station.

10.3 Using Symbol Files

Specifying the Use of Symbol Files

The PROFINet tool “SIMATIC iMap” creates a symbol file for the OPC server. Read the documentation of SIMATIC iMap for information on creating a symbol file.

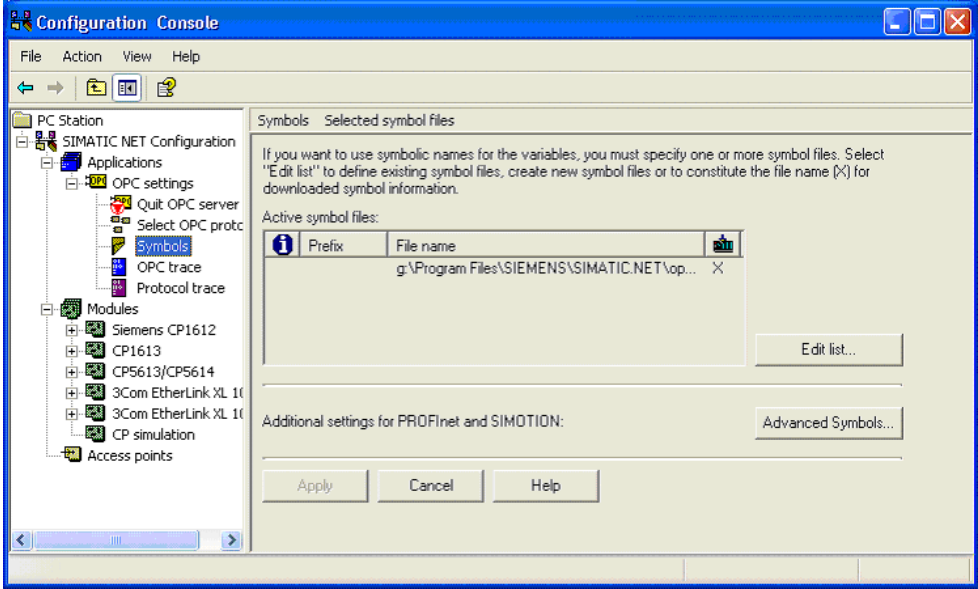
Activity	
1.	<p>You can define hierarchically structured symbolic names for all OPC variables and use them in your OPC client programs. You can extract these symbols from a STEP 7 project.</p> <p>You can open the Configuration Console from the Start menu (Start ► SIMATIC ► SIMATIC NET ► Settings ► Configuration Console).</p> <p>Select “Symbols” and select the symbol file you want to use (browse for the symbol file or create a new one with “Edit List”).</p> 
2.	Click the “Start” button to start the Symbol File Configurator.

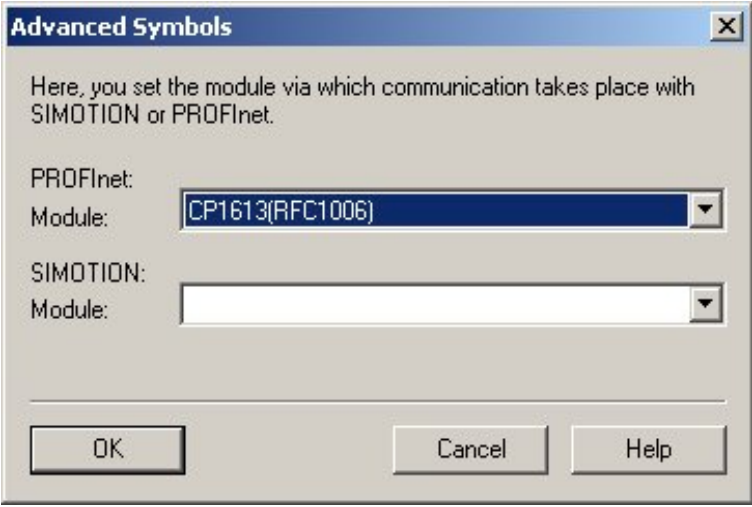
Activity	
3.	<p>Select the device parameter assignment “CP1613 (RFC1006)” as the PROFINet module and confirm the dialog:</p>  <p>Confirm with “OK”.</p>
4.	<p>The last dialog box of the Commissioning Wizard appears. Click the “Finish” button to complete your work with the wizard.</p>

Note

It is only necessary to make settings in advanced symbols, if the “S7_extended” attribute was set during project engineering of the PROFINet data blocks. In this case, extended S7 functionality is used alongside PROFINet. If this functionality is not used, the setting in advanced symbols is irrelevant.





11 Station Configuration Editor Tool

With the Station Configuration Editor, you can access the component management of the Station Manager in the PC station. You require the Station Configuration Editor for the initial configuration and for project engineering and maintenance of a PC station.

11.1 Characteristics, Functions and Activation

The Station Configuration Editor is the user interface of the Station Manager.

The components are the modules and the applications involved in communications in the PC station. These components require configuration and project engineering data that is managed by the Station Manager in component management (database).

Apart from component configuration, the Station Configuration Editor can also be used for diagnostic purposes.

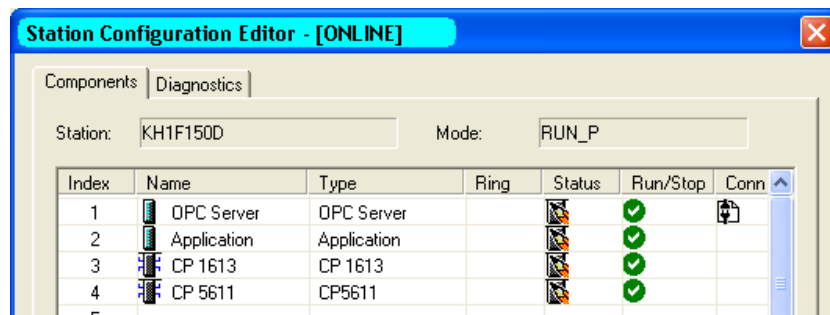

Station Manager with component management (database)

- Configuration of components
- Project engineering data (connections and symbols)

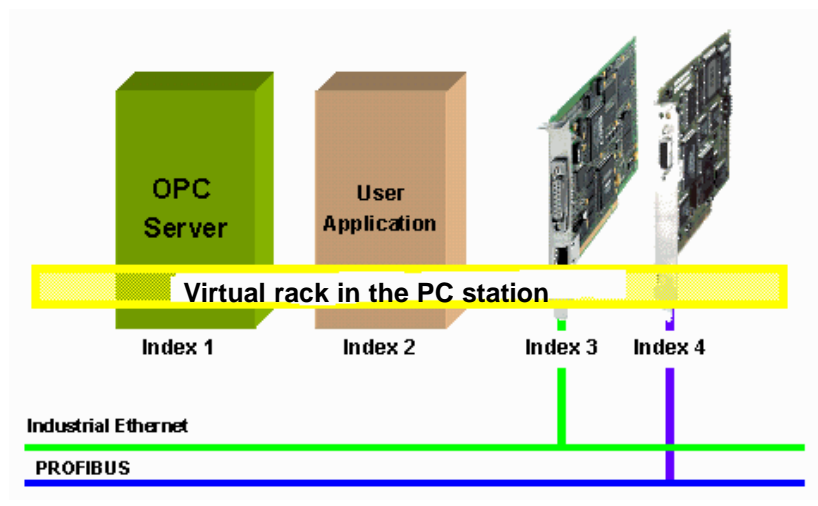

Figure 11-1 Component Management of a PC Station



Area of Application / Use Cases

- Initial configuration (commissioning)

When a module is started up for the first time, it must be configured. This initial configuration is necessary for all newly installed modules. When you first configure the module, an index (the “virtual slot number”) is assigned.

After the initial configuration of the modules, the PC station is prepared to receive project engineering data. This step can be compared with inserting the component in the rack of an S7 station.

- Project Engineering and Maintenance

Changes in the project engineering and in the configuration data can be downloaded from the project engineering tool to the PC station (local and remote). As an alternative, it is possible to transfer data using an XDB file (if the station is not networked).

Using the Station Configuration Editor, you can check the effects in the “Components” tab. The “Diagnostics” tab provides you with information on the operating state at any time.

By adding the communication module in the Station Configuration Editor, the module is automatically switched to the “configured mode”; as default, modules are set to “PG operation”.

How to Start the Station Configuration Editor



The Station Configuration Editor is always available and started on the PC station on which you have installed the SIMATIC NET CD. You can bring it to the foreground by clicking the icon shown here in the taskbar of the Windows desktop (SYSTRAY).

11.2 Managing Components: “Components” Tab

In the “Components” tab, you will find the essential functions for PC configuration and project engineering.

- Assigning the station name
- Creating new components
- Adopting a component configuration and project engineering data (online or offline mode)
- Setting the mode - online or offline
- Checks and diagnostics

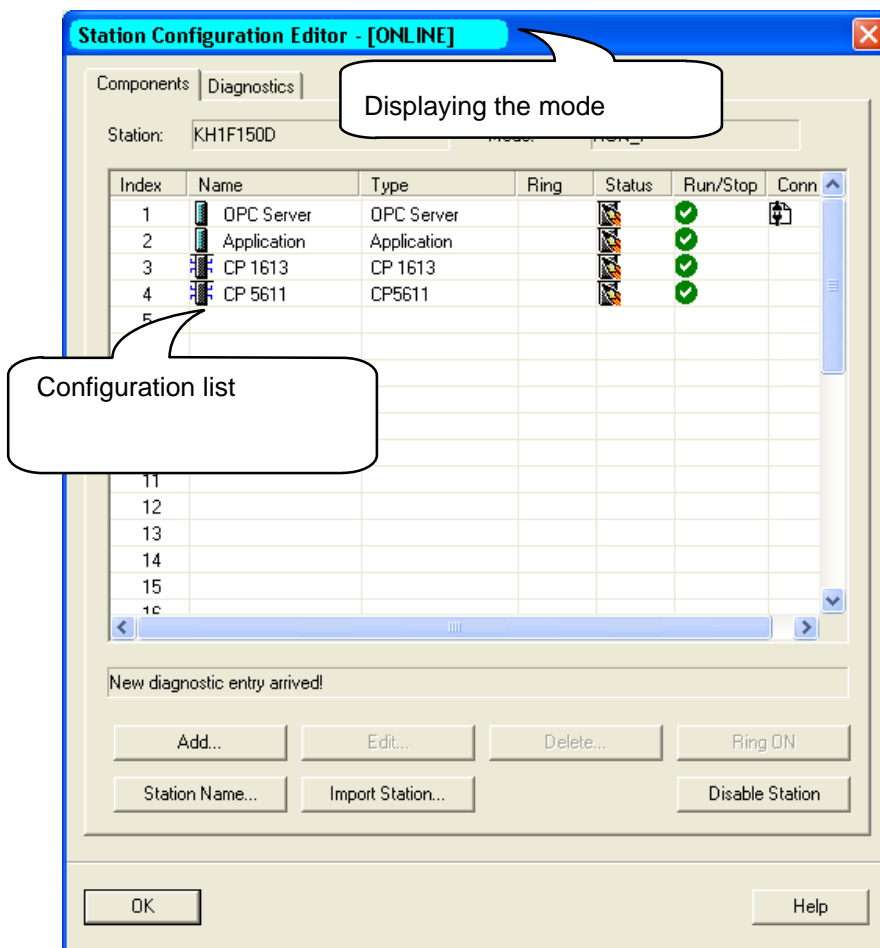

Note

You will find more information on the meaning of the display boxes and the buttons in the integrated help system.

Assigning the Station Name

You can assign a name for the PC station by clicking the “Station Name” button.

To be able to identify a project engineering configuration that is already loaded locally, the name assigned here must match the name you assigned to the PC station in the project engineering communication settings with NCM PC / STEP 7.



Creating New Components

You can select the components installed on your PC station (applications, OPC Server, modules such as controllers) by clicking the “Add” button. The modules are detected automatically.

Notice

The components in the configuration list you can edit here must be entered in exactly the same order as in the component image you created in SIMATIC NCM PC with HW Config. If the configuration differs from the list, the configuration data that you download from SIMATIC NCM PC to the PC station will not be adopted correctly.

The status display constantly informs you whether the component you have created matches the current hardware configuration and whether it matches any project engineering data that has already been downloaded.

Note

Remember that you have the option of a partial load if you have set the properties of the Station Configuration Editor accordingly.

For more detailed information, refer to the following section “Setting the Station Configuration Editor: Properties Dialog”.

Adopting the Component Configuration and Project Engineering Data

For productive operation, you require not only the component configuration but also the project engineering data for the communication connections and possibly also for the symbols of variables.

You have the following options:

- Downloading using the project engineering tool

In online mode, you can download the project engineering data directly to the PC station using NCM PC / STEP 7. You can download both locally or over the network.

- Station import

If the station is not networked, you can load the component configuration and project engineering data by importing the XDB file on the PC station (for details on creating an XDB file, see Section 12.8).

The XDB file can be imported using the “Import Station” button in the Station Configuration Editor.

Importing the XDB file is possible only when the actual current module configuration exactly matches the information in the XDB file.



You can import an XDB file at any time regardless of the current mode (online or offline). You can also specify (option) whether you want the “offline mode” to be set following the import.

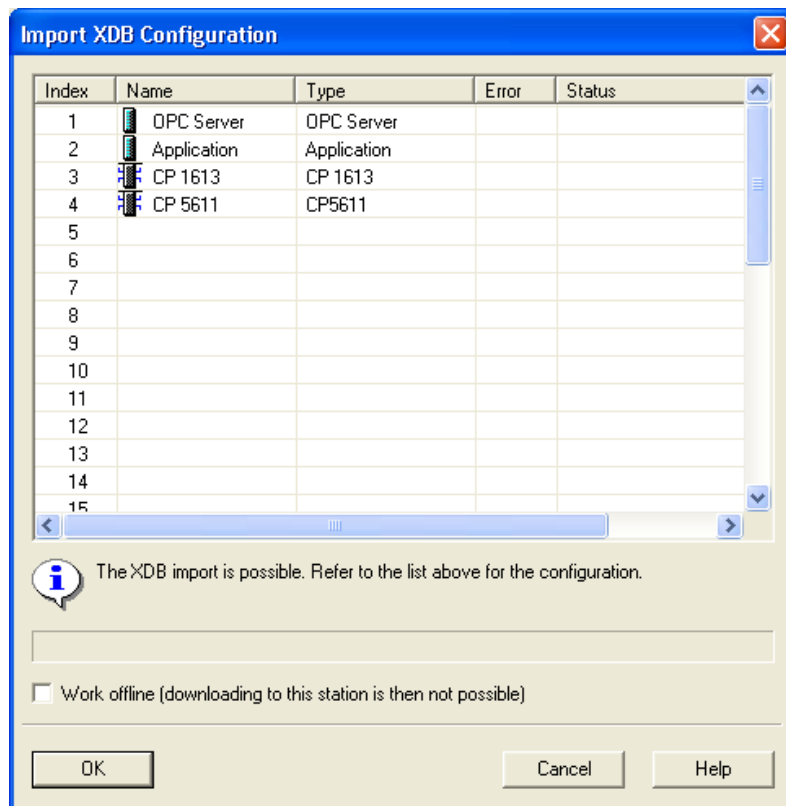

Setting the Online or Offline Mode

The current mode is displayed in the in the title bar of the Station Configuration Editor.

- Offline mode

In offline mode, you can make changes to the configuration only by entering them directly or by importing the station (XDB file).

In offline mode, you can click the visible “Change mode” button to change to online mode.

- Online mode

In online mode, you can download the project engineering data directly to the PC station using NCM PC / STEP 7. You can download both locally or over the network.

In online mode, you can also import an XDB file at any time. You can also specify (option) whether you want the “offline mode” to be set following the import.



Checks and diagnostics

- Note on diagnostic entries

The entry in the “Status” field in the configuration list constantly informs you whether or not the created component matches the actual hardware configuration and whether there is a match to an existing loaded project engineering database.

If this is the case, you will be prompted to select new diagnostic entries in the “Diagnostics” tab.

- Checking the Accessibility of the Module - “Ring” Function

Once you have finished configuring, you can check the accessibility of the modules, by clicking the “Ring” button. If the module supports this function, you will see an indicator respond on the module.

11.3 Evaluating Messages: “Diagnostics” Tab

How It Works

The Station Configuration Editor manages a diagnostic buffer in which the PC station components (hardware and software) enter event information.

You can use this list to analyze configuration or communication problems.

Note

You will find more information on the meaning of the display boxes and the buttons in the integrated help system.

11.4 Setting the Station Configuration Editor: “Properties” Dialog

You open this dialog by right-clicking on the icon of the Station Configuration Editor in the Windows taskbar (SYSTRAY).

In the Properties dialog of the Station Configuration Editor, you can make the following settings:



Configuring Activation of Warnings

When warnings are enabled, a new event in the diagnostic buffer causes a display in the station manager ICON in the system tray. Whether a warning is indicated depends on the set warning level.

Here, you can configure the warning activation (yellow ! character) over the Station Manager icon in the system tray of the taskbar. The following settings are possible:

- Activate warnings on or off
- Select warning activation depending on the weighting of the error:
 - When errors and important errors occuror
 - Only when important errors occur.

Default setting: Only when important errors occur.

Accept Partial Loading

If the “accept partial loading” property is activated, the Station Manager also accepts defined configurations that contain only part of the configuration visible in the Station Configuration Editor.

The components (modules and applications) that do not receive an engineered configuration are fully deleted if you download only part of the configuration (engineered configuration is lost). These are, however, retained in the configuration of the station manager (with the appropriate status displayed: Component does not exist or is not configured in the current PC station configuration).

Default setting : Accept partial load.



12 SIMATIC NCM PC Project Engineering Tool

SIMATIC NCM PC is the central tool for configuring the communications services for your PC station. After creating your configuration data with this tool, you then download it or export it to the PC station. The PC station is then ready for communication.

12.1 Characteristics, Functions and Activation

SIMATIC NCM PC is a version of STEP 7 especially for project engineering of PC stations. It provides the full range of features of STEP 7 for PC stations.

SIMATIC NCM PC comprises the following main components:

- **SIMATIC NCM PC Manager**
Provides functions for project and component management. From here, you can start the other tool components.
- **SIMATIC NCM PC Config**
This is required to configure PC stations and their components.
- **NetPro**
This is primarily used for the project engineering of connections and communication properties of the SIMATIC NET OPC server and applications.

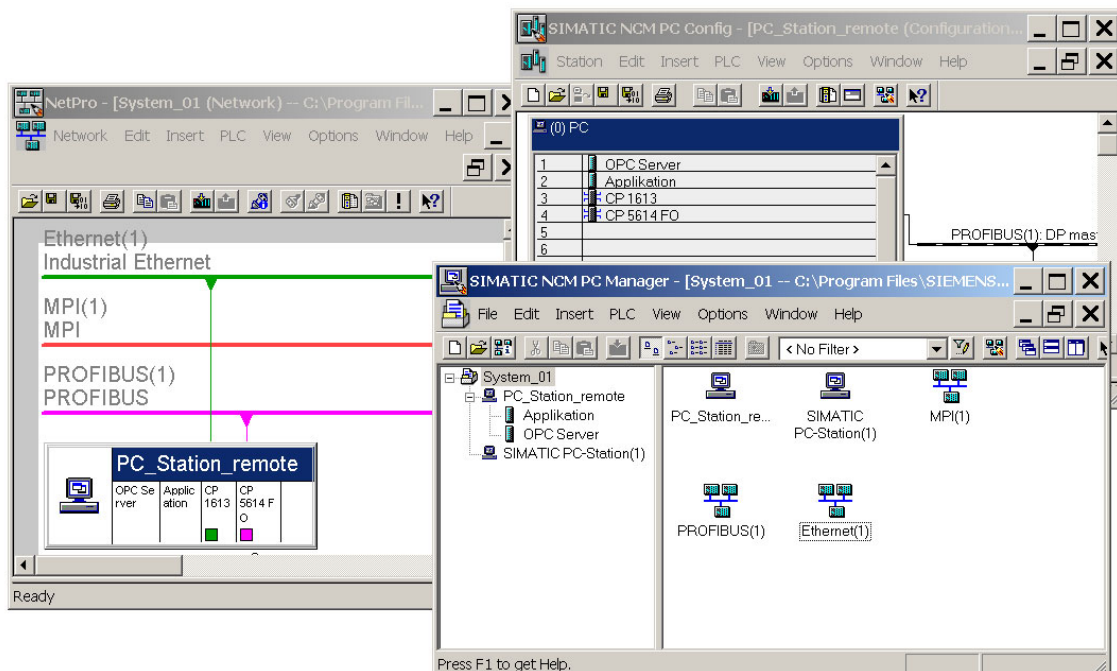



Functions

To create the configuration and project engineering data of a PC station, use the following functions:

- Creating and configuring components of the PC station
- Setting communication properties of the SIMATIC NET OPC Server in the project engineering
- Configuring connections in the project engineering
- Adopting symbols from the SIMATIC S7 project engineering
- Configuring the DP mode in the project engineering
- Setting network parameters for PROFIBUS and Ethernet operation
- Downloading project engineering data to PC stations
- Storing configuration and project engineering data in an XDB file
- Monitoring communication to attached S7 stations with NCM Diagnostics

Initial Configuration with XDB File

You can always perform the initial configuration of your PC station by transferring configuration and project engineering data using an XDB file.

This is possible because you must create the components (modules and applications) completely in SIMATIC NCM PC to be able to create their communication connections in project engineering.

Transferring this data as a download is only possible after the initial configuration of the PC station.

Note

You can configure both in SIMATIC NCM PC and in STEP 7. STEP 7 also provides all the SIMATIC NCM PC functions described here for configuring your PC. STEP 7 is necessary if you also want to configure S7 stations in the project.

From now on, the description will only refer to SIMATIC NCM PC but nevertheless applies to both.

Notice

Optional packages are not supported by SIMATIC NCM PC. If you are editing a project that was created or edited in STEP 7, it may contain components from STEP 7 optional packages. If this is the case, you can only edit stations using SIMATIC NET PC that do not contain components from STEP 7 optional packages.



How to Start SIMATIC NCM PC

Go to the Start menu and select **Start ▶ SIMATIC ▶ SIMATIC NCM PC Manager** .

Further Information in Help

The following integrated help system functions will also provide you with detailed information:

- **Help ▶ Introduction**

Contains a brief description of SIMATIC NCM PC

- **Help ▶ Getting Started**

Here you will find brief instructions on how to create a PC station, its applications and modules. For more detailed information, you can go from here to the PC topics in the main help system.

These instructions are available only in Help on SIMATIC NCM PC. In STEP 7, select the Help menu directly:

- **Help ▶ Contents**

Here you will find help topics relating to the PC station under:

- Configuring Hardware / SIMATIC PC Station
- Configuring Connections for a SIMATIC PC Station



12.2 Relationship Between SIMATIC NCM PC and STEP 7

SIMATIC NCM PC and STEP 7 are compatible with each other.

- You can open and edit projects that you created with SIMATIC NCM PC at any time in STEP 7/SIMATIC Manager. This allows you to use additional functions for programming and configuring S7 stations.
- You can open and edit projects that you created with SIMATIC NCM PC at any time in STEP 7/SIMATIC Manager. You can edit PC stations you have already created and create new PC stations. You can configure communication connections from these PC stations to existing S7 stations.

NCM PC Can Use STEP 7 Project Data

The restrictions in SIMATIC NCM PC relate to the station types that can be created. The project engineering for S7 stations and programming them can only be done in STEP 7.

The types of stations that you can configure only in STEP 7 can be used in SIMATIC NCM PC as target stations for a connection configuration after importing the project.

The symbol files created for the S7 stations can also be used by the OPC server. You decide on these settings when you create the project engineering data for the OPC server.

After working on such a project in SIMATIC NCM PC, you can return it to STEP 7 and edit it again at any time.

STEP 7 provides extra functions for testing and diagnostics.



The following graphic illustrates the differences once more:

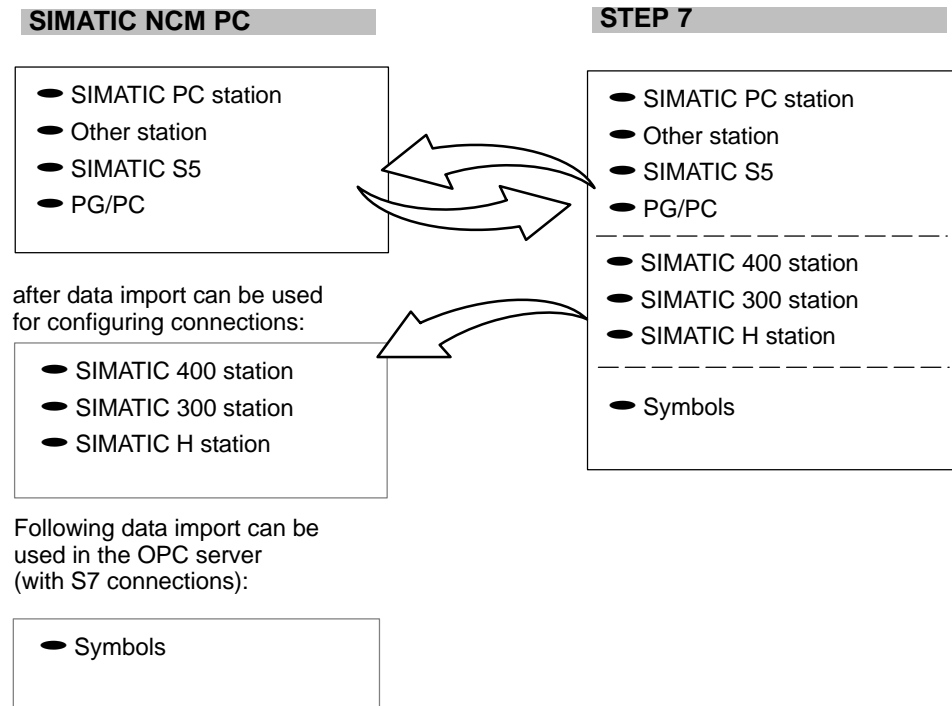



12.3 Creating a PC Station

The PC Station in the STEP 7 Project

The “SIMATIC PC Station” is an object in a SIMATIC STEP 7 project. A typical PC station for OPC operation consists of the following elements:

- One or more communications modules (CPs)
- An OPC server application and/or other applications
- In some situations, other controlling elements such as soft PLC or slot PLC

One CP is connected to a PROFIBUS or Ethernet network over which other communication partners can be reached.

Within the OPC server application, connections can be created and used for various protocols that describe the communications relations with the partner devices.

Aims

You want to create configuration and project engineering data for communication services for individual PC stations. This database will then be downloaded to the PC station. After this, the PC applications can use the communications services.



Tip:

Remember that with the PC Station Wizard, you can include the configuration of the local PC station in an existing or newly created project largely automatically!

You can use this in the following ways:

- On a local station, in other words, when your engineering station is the PC station at the same time, the parameters specified in the initial configuration with the Station Configuration Editor tool can be transferred later to the local project engineering system.
- For transferring the data to an engineering station

To allow the information from the project engineering to be transferred from an engineering system to the PC station, the local configuration must match the configuration data entered in the project engineering. To make sure of this, you can create project engineering data locally on the PC station and then import it later into the project engineering system.

For more information on starting and using the tool, refer to Chapter 13 and the chapters with examples in this manual.



Creating and Managing Objects

After starting SIMATIC NCM PC, you either open an existing project or create a new one. You use projects to manage your configurations consisting of all or part of the stations of your plant.

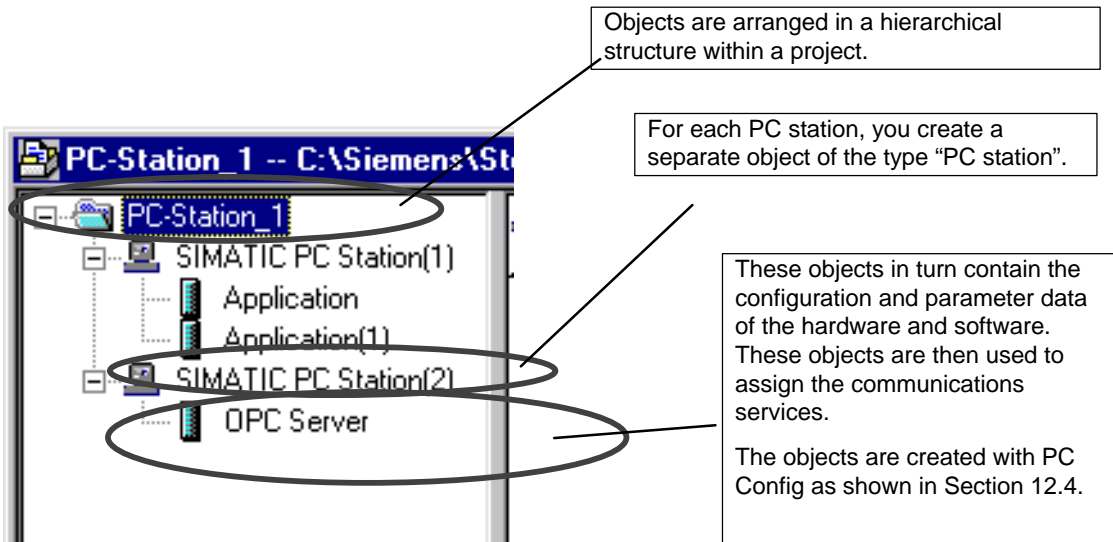

Notice

The name of the PC station you select here identifies the PC configuration.

- If you configure on the local station with NCM PC, you must select the name identical to the name in the local configuration.
- If you configure a remote PC station, the name you select must not be identical to the local PC configuration! When you download, you would otherwise overwrite the local configuration.

Tip: You can also adapt names, when necessary, in the Station Manager using the Station Configuration Editor.

Follow the steps below:	
1	Start the SIMATIC NCM PC Manager.
2	You can create the stations with the insert objects function.
3	Opening a station object starts the HW Config tool with which you can create the configuration of a PC station consisting of modules and applications (see the following page).



Note

When you start STEP 7, a wizard is opened that helps you to create a new project.

In SIMATIC NCM PC, this wizard is replaced by the PC Station Wizard. Depending on your initial situation, this wizard provides you with more extensive support for your PC station.

The PC Station Wizard also exists in STEP 7.



12.4 Configuring a PC Station with SIMATIC NCM PC Config

Creating an Image of the PC Configuration

To allow the configuration data sent by the configuration system to be assigned to a module or an application, it must have a unique identification number. The identification number for modules, applications, and other components in a PC station is the index.

You place your applications and modules in slots in a “virtual rack” in HW Config. This slot number then corresponds to the index mentioned above.

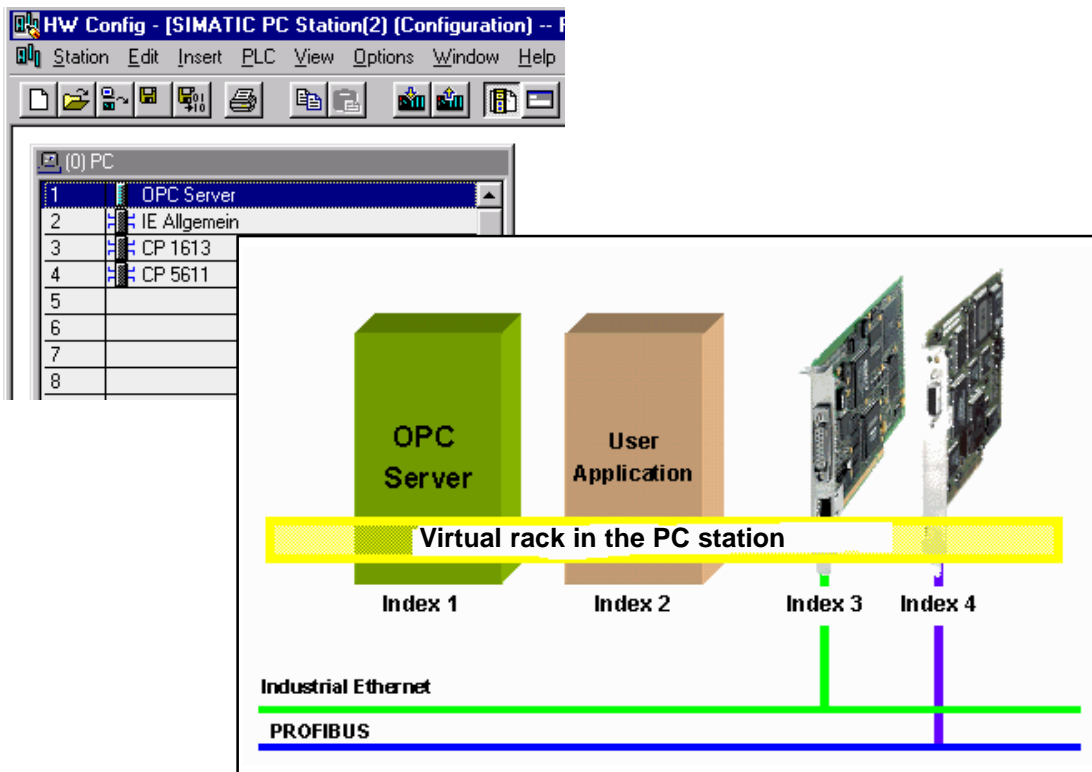

Figure 12-1 Component Management of a PC Station

Note:

This procedure corresponds to the one already described for the “Station Configuration Editor” tool.

Notice

Be careful not to confuse this “index” with a hardware slot, for example on the PCI bus of the PC station. The slot on the PCI bus is not relevant for commissioning and is not used at any point.

**Follow the steps below:**

Drag the components from the catalog to the list (the “virtual rack”) displayed in PC Config.

Notice

Please note the following if you are transferring data by downloading:

Make sure you arrange the components exactly the same as in the configuration list of the Station Configuration Editor (see Section 11.2). If the configuration differs from the list, the configuration data that you download from SIMATIC NCM PC to the PC station will not be adopted correctly.

Index	Module	Order number	Firm...	M...	C...
1	OPC Server		V6.1.0		
2	IE Allgemein	IE_CP			
3	CP 1613	6GK1 161-3AA00	V6.0.5		
4	CP 5611	6GK1 561-1AA00	V6.0.5		
5					
c					

OPC Server
OPC Server for the DP, FDL, FMS, S7 (between subnets), ISO/TCP, SNMP, DP master class 2, protocols, SIMATIC NET CD 11/2002 ...

Note: This display shows the situation after configuring in with STEP 7 / HW Config; in SIMATIC NCM PC, only the components for the PC stations are available in the catalog.



PC Components in the Catalog

For the SIMATIC PC station, you can select the following components:

• Application

- Application (standard application)

You use standard interfaces to communicate with other applications and devices via your PC module.

The user programs included in the application use suitable interfaces for communication, such as the SAPI programming interface or the SEND/RECEIVE programming interface.

You can configure the following communications services depending on the module inserted:

- Connection-oriented services
- DP services (for example, DP-V0 and DP-V1)

Note how these differ from the user programs that use the communication service as OPC clients via an OPC Server as described below.

- OPC Server

You use the convenient interface to an OPC server to communicate with a programmable controller such as a SIMATIC S7-400.

The OPC Server can be configured as an interface to all available communication protocols. You can create this object only once in a PC station.

You can then use this OPC Server for communication with any number of user programs (OPC clients).

The following communications services can be used depending on the modules inserted:

- All types of connection
- DP services

• CP Industrial Ethernet

This contains all the CP modules for attachment to Industrial Ethernet.

• CP PROFIBUS

This contains all the CP modules for attachment to PROFIBUS.



12.5 Creating the DP Master System

Read the information below if you want to use a PROFIBUS CP and configure a DP master system.

Significance of the Configuration Data in a DP Master System

The configuration data inform the DP master in the PC station of the data and address areas of the attached slaves.

Depending on the type of slave, this information is either implicitly linked to the entry in the catalog or must be configured here additionally as, for example, when using an intelligent DP slave such as the CP 342-5.

Follow the steps below:	
1	You have already placed the applications and modules as described in Section 12.4.
2	After you have taken the module from the catalog, you can select it and create a DP master system using the Insert menu command.
3	Select the application that will address the master system (the DP slaves).

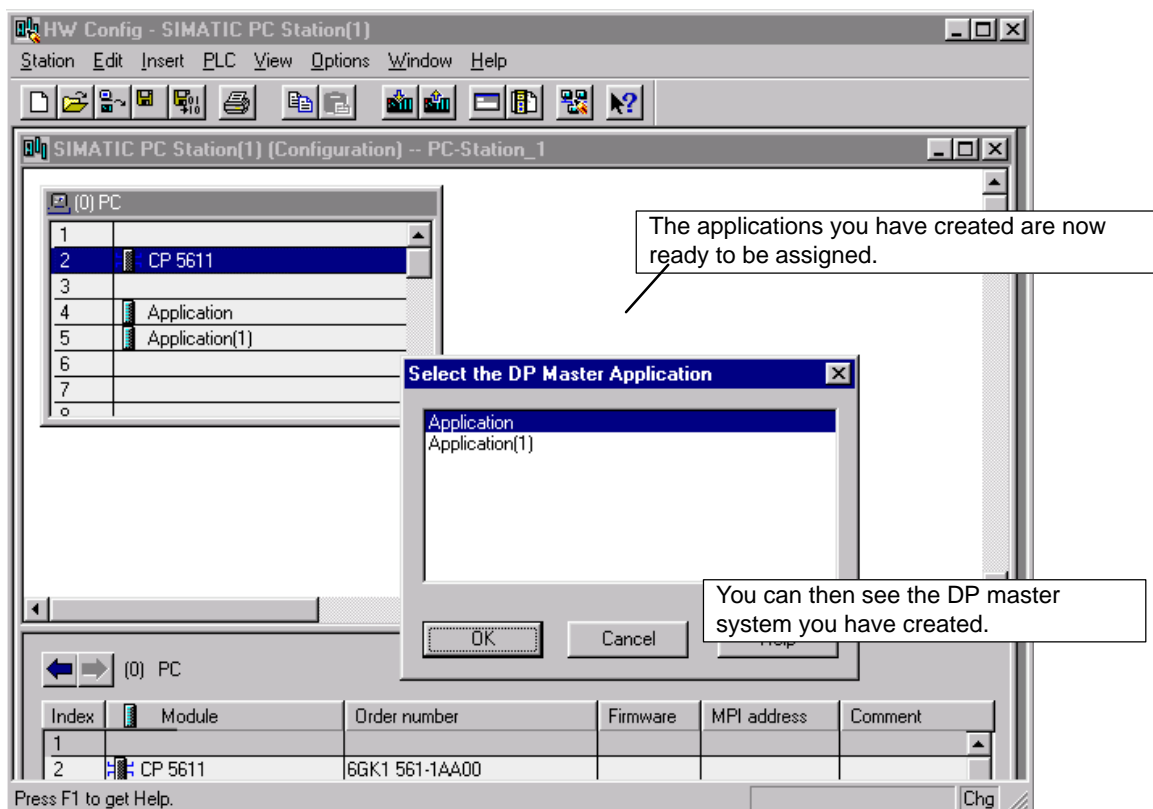



Now insert the DP slaves you want to be addressed by the application from the catalog.

Drag the DP slave from the catalog onto the icon of the DP master system.

The screenshot shows the SIMATIC HW Config interface. On the left, a rack configuration for 'PC Station 1' is shown with slots 1-7. Slot 2 contains a 'CP 5611' module, and slots 4-5 contain 'Application' and 'Application(1)' respectively. A 'PROFIBUS(1): DP master' system is connected to a '(1) B-16DO' DP slave module. On the right, the 'Hardware Catalog' is open, showing a tree view of components under 'PROFIBUS DP'. The 'ET 200B' folder is selected. Below the catalog, a table displays the configuration for the selected '(1) B-16DO DP' module.

Slot	Module / ...	Order number	I Address	Q Address	Comment
0	16DO	Universal module		0..7	
1	0	Universal module			



12.6 Creating a PROFINET IO System

The following information applies if you want to use an Ethernet CP as PROFINET IO controller in the PC station and want to configure a PROFINET IO system.

Significance of the Configuration Data in a PROFINET IO System

The configuration data inform the PROFINET IO controller in the PC station of the data and address areas of the connected PROFINET IO devices.

This data also includes the device names which the PROFINET IO controller assigns to the PROFINET IO devices during startup.

Follow the steps below:	
1	You have already placed the applications and modules as described in Section 12.4.
2	After you have taken the module from the catalog, you can select it and create a PROFINET IO system using the Insert menu command. If required, you can also connect an existing PROFINET IO system with the PROFINET IO controller you have just created by selecting the CP, right-clicking, and then selecting the "Connect PROFINET IO System" menu command.
3	Select the application (OPC server or application) that will address the PROFINET IO system (the PROFINET IO devices).

The applications you have created are then displayed and available for assignment.

Finally, you will see the created PROFINET IO system.

Index	Module	Order number...	Firmware
1	OPC Server		V6.2.1
2	Applikation		
3	Applikation(1)		
4			
5			
6	CP 1612		
7			

Select the PROFINET IO Controller Application

Applikation
Applikation(1)
OPC Server

OK Cancel Help



Follow the steps below:

4 Now go to the catalog and insert the IO devices that will be addressed over the application.

Drag the IO device from the catalog onto the icon of the PROFINET IO system.

Slot	M...	Order number	Diagnostic address
0	IE-PB-L	6GK1 411-5AB00	16,381*
1	PROFI	6GK1 411-5AB00	16,382**

Press F1 to get Help.

PROFINET IO Devices

PROFINET IO devices are field devices that can be connected either directly to Ind. Ethernet or can be connected as PROFIBUS DP slaves to a DP master system. By using an IE/PB Link PN IO, you can address the DP slaves of a DP master system just like PROFINET IO devices.

You will find further information here:

- Project engineering

In the basic help of STEP 7 / SIMATIC NCM PC in the topic “Steps in Configuring a PROFINET IO System”, you will find a detailed description of how to configure a PROFINET IO system.

- PROFINET IO - System Descriptions: see /18/ /19/



12.7 Configuring Connections

Meaning

During operation, configured connections are established either implicitly or on request, depending on the parameter assignment. They are then available to the OPC Server or the PC application for communication.

General Rules

Regardless of the application type, the general rules for connection configuration apply:

- Communication connections are always assigned to an application.
- In the PC station, the CP that supports the type of connection is used for the data transfer.
- If there is more than one CP with this capability, you can use Routing to select the transmission path.

Follow the steps outlined below:																			
1	Select the application to which you want to assign a connection. <table border="1"><thead><tr><th>Local ID</th><th>Partner ID</th><th>Partner</th><th>Type</th><th>Active connection partner</th><th>Subnet</th></tr></thead><tbody><tr><td>S7 connection_1</td><td>S7 connection_1</td><td>SIMATIC PC Stati...</td><td>S7 connection</td><td>Yes</td><td>PROFIBUS(1)</td></tr><tr><td>S7 connection_2</td><td>S7 connection_2</td><td>SIMATIC PC Stati...</td><td>S7 connection</td><td>Yes</td><td>PROFIBUS(1)</td></tr></tbody></table>	Local ID	Partner ID	Partner	Type	Active connection partner	Subnet	S7 connection_1	S7 connection_1	SIMATIC PC Stati...	S7 connection	Yes	PROFIBUS(1)	S7 connection_2	S7 connection_2	SIMATIC PC Stati...	S7 connection	Yes	PROFIBUS(1)
Local ID	Partner ID	Partner	Type	Active connection partner	Subnet														
S7 connection_1	S7 connection_1	SIMATIC PC Stati...	S7 connection	Yes	PROFIBUS(1)														
S7 connection_2	S7 connection_2	SIMATIC PC Stati...	S7 connection	Yes	PROFIBUS(1)														
2	Enter the desired connection type. You will be requested to specify the negotiating partner.																		



Connections to S7 Stations

When you configure systems that include PC stations and SIMATIC S7 stations, the use of STEP 7 is generally advisable. You can then edit and process every station type completely and with full functionality.

After creating a new project in SIMATIC NCM PC, you will find that the required destination station (for example an S7 station) may not exist depending on the particular application intended. You then have the following options:

- Create an unspecified connection

Select "unspecified" as the connection partner. In the Properties dialog box, you can then set the address parameters for the connection partner.

- Create a proxy object

Create an "Other Station" type station. You then network this station by assigning the necessary interface types in the Properties dialog.

This method is advisable if you intend to assign several connections to this partner station on the same interface in your project.

- Create a copy of an S7 station

Insert the copy of an S7 station that you have created using STEP 7 in another project. You can then select this S7 station as your destination station.



12.8 Downloading Project Engineering Data to the PC Station (after Initial Configuration)

To allow applications to exchange information over configured communication connections, the project engineering data created with NCM PC / STEP 7 must be loaded on the PC station.

If the initial configuration was performed with XDB import of the project engineering data, loading is already completed with the initial configuration.

The section below describes how project engineering data can be downloaded to the PC station after the initial configuration. This is necessary when the project engineering data is not yet available at the time of the initial configuration, or to make changes to the project engineering data.

Network, Local Load, and XDB File

There are three possible ways of transferring a configuration from the project engineering to the PC station

- Online mode
 - networked (engineering station networked with runtime PC)
 - locally (project engineering station and PC station one and the same)
- Offline mode (engineering station and runtime PC separate) - XDB import

Notice

Downloading as described below only results in successful installation of the communications services on your PC station if the arrangement of the components in the configuration data is identical with that of the configuration data on the PC station.



12.8.1 Online Mode

The online mode allows you to download the configuration data directly to a PC station attached to the network (MPI, PROFIBUS or Ethernet), or to load the data on the local PC station if you are using this as the configuration station.

- **Online mode - networked (engineering station networked with runtime PC)**

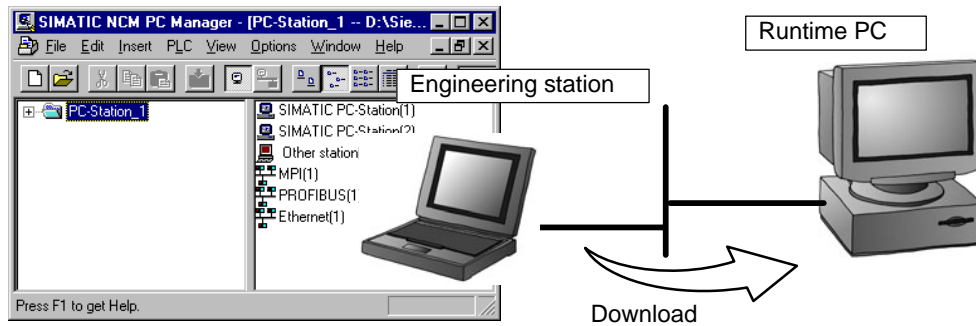

Use this option when the following requirements are met:

- The PC station (runtime PC) is not the configuration station.
- The PC station (runtime PC) is linked to the configuration station via a network. The PC station is accessible as a communications node, for example after setting the parameters in the initial configuration.
- A connection exists that can, for example, be checked using the “Accessible Nodes” function.

Follow the steps below:

	Procedure for “Downloading Project Engineering Data to the PC Station” - Online - Networked	Tool
1.	Check the following on the runtime PC: <ul style="list-style-type: none"> • The mode is set to online. • The runtime PC is not disabled. 	Station Configuration Editor
2.	Select the station you want to download to.	NCM PC / STEP 7
3.	Download the configuration data with PLC -> Download If you are using PG operation: Make sure that you set the correct interface using the Set PG/PC Interface tool (Access point “S7ONLINE”).	NCM PC / STEP 7

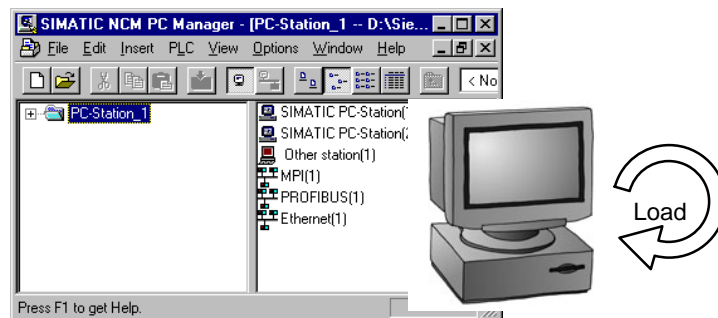
**• Online mode - local (configuration station and PC station identical)**

This situation occurs when the configuration system is installed on the PC station (engineering station).

In this case, the configuration data are transferred directly over an internal PC connection. Within the configuration system you still use the known mechanisms for accessing the target system as in case a).

Follow the steps below:

	Procedure for “Downloading Project Engineering Data to the PC Station” - Online - Local	Tool
1.	Make sure that the following requirement is met: The access point of the application must be set as follows: S7ONLINE (STEP7) -> PC internal (local)	Set PG/PC Interface
2.	Select the station you want to download to.	NCM PC / STEP 7
3.	Download the configuration data with PLC -> Download	NCM PC / STEP 7



Using the PC Station Wizard.

In the situation described here, “online - local”, the use of the PC Station Wizard is also possible.

If you have not yet created the project engineering data for the PC station in NCM PC / STEP 7 following initial configuration or the configuration has changed compared with an existing project engineering database, you can transfer the current configuration to the project engineering database with the PC Station Wizard.

Of those offered, the following options can be selected:

- Changing local settings:

The wizard can synchronize the configuration data with existing project engineering data.

- Creating a new configuration:

The wizard helps you to create a new project that already contains the known modules in a preconfigured PC station.

You can then, for example, import a project created in this way into a project engineering database on an engineering station (copy the station or import the project into a multiproject).

12.8.2 Offline Mode (Engineering Station and Runtime PC Separate) - XDB Import

If you are working offline, you will require an XDB file to transfer the data. The configuration system always generates an XDB file for each configured PC station.

The storage location of the configuration file can be found in the properties of the “PC Station” object in the configuration system. The PC Station Wizard can use this file on the PC station or it can be imported in the Station Configuration Editor.

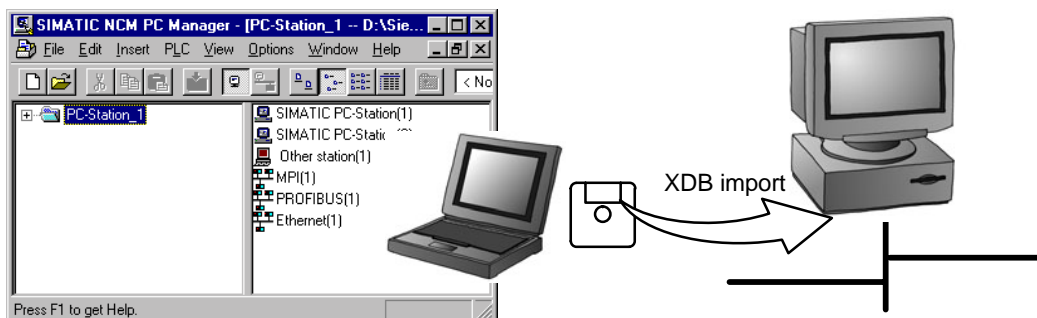



Note

To make it possible to identify the PC station, the station name in the configuration must match the locally configured station name. If this is not the case, it is not possible to adopt the configuration on the PC station!

Set the station name, if necessary, in the Station Configuration Editor.

Follow the steps below to create and import an XDB file:

	Procedure for “Downloading Project Engineering Data to the PC Station” - Offline	Tool
1.	Select the station you want to load to in the STEP 7 project.	NCM PC / STEP 7
2.	Open the object properties of the station with the “Station Properties” menu command and select the “Configuration” tab.	NCM PC / STEP 7
3.	Here, you can check and, if necessary, change the setting under “Storage Location of the Configuration File”.	NCM PC / STEP 7
4.	Save and compile your project; you will then find the required XDB file in the folder you have selected. Note: The station name must be identical in the defined configuration and on the local PC station (entry in the Station Configuration Editor).	NCM PC / STEP 7
5.	Copy the XDB file onto a data medium that the destination station can access.	NCM PC / STEP 7
6.	Import the XDB file into your destination station using the Station Configuration Editor.	Station Configuration Editor



12.9 Adapting Mismatched Configurations

The Station Configuration Editor displays assigned indexes

If you cannot download configuration information to the PC station, this may be due to a mismatched configuration. The Station Configuration Editor will provide you with an overview of the indexes allocated to the PC station. This is the tool for setting up the components installed in the PC station.

Adapting the Configuration

There are two ways of matching up the actual local configuration of the PC station and the defined configuration as in your project.

- Adapting the assignment in the defined configuration

Change the assignment of the modules configured on the PC in the defined project configuration using NCM PC / PC Config so that it matches the configuration recognized by the Station Configuration Editor.

- Changing the configuration on the PC station

Using the “Station Configuration Editor” program, you can assign a new index to a component and add components that are not set for operation as defined in the project to the defined operating configuration.

You should also read the description of the “Station Configuration Editor” tool in Chapter 11.



13 PC Station Wizard

The PC Station Wizard supports you when creating projects in SIMATIC NCM PC or STEP 7. It allows the automatic adoption of configuration on the local PC station. This helps you to make sure that your configuration data is consistent.

A typical use case, for example, would be transferring the configuration of a PC station to a “temporary” STEP 7 project. This project can then be transferred to an engineering station (inserting the PC station in another project by copying or importing the project into a multiproject).



Tip:

- Read through the chapters with the examples in this manual.

How to Start the PC Station Wizard

Double-click on the icon of the PC Station Wizard on your Windows desktop:

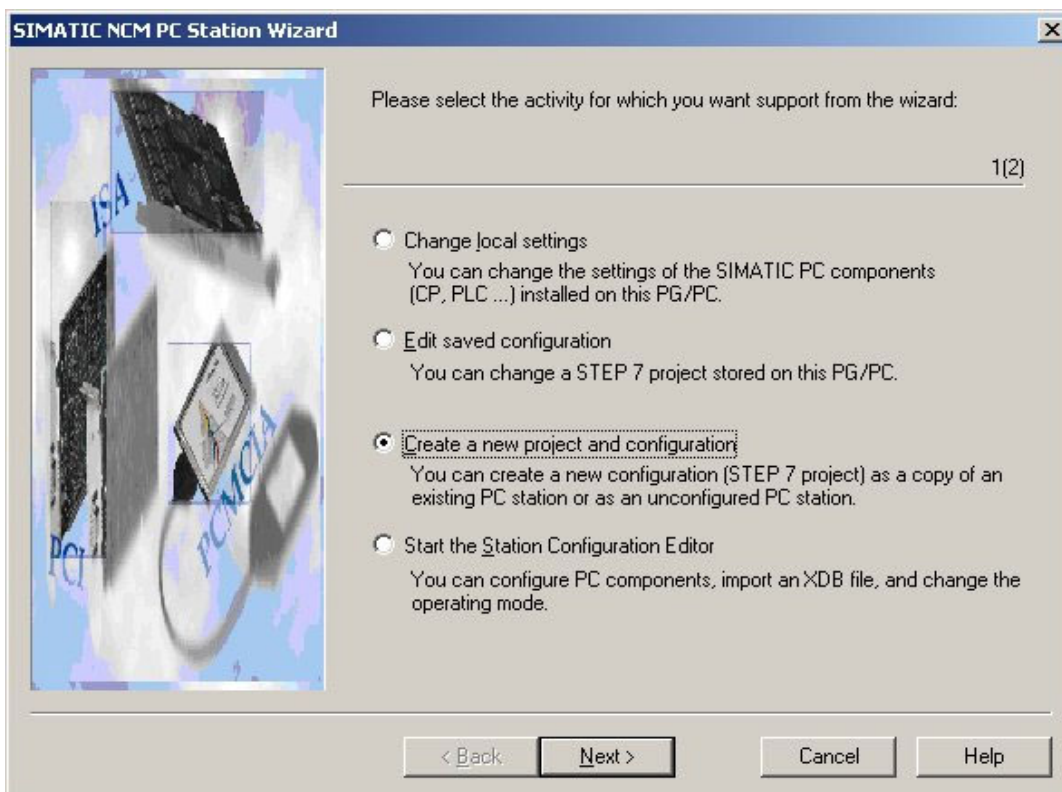

**The PC Station Wizard supports you in the following situations:****• Changing local settings**

If the SIMATIC NCM PC configuration tool is installed on the destination PC station, the wizard can compare the configuration data with the planned configuration data that already exist. The communications parameters can then be edited in the project directly.

• Editing a saved configuration

Open an existing project and compare the local configuration with the information in the project.

In contrast to the “Change local settings” function, the configuration edited here is independent of an existing local configuration.

• Creating a new configuration

If the SIMATIC NCM PC configuration tool is installed on the destination PC station, the wizard can create a new project and enter the local configuration in the project.

• Starting the Station Configuration Editor



14 Symbol File Configurator Tool

With the Symbol File Configurator, you can create symbol files that allow you the option of access to symbolic variables over the SIMATIC NET OPC server.

A symbol file is structured hierarchically and has a structure similar to a file system.

14.1 Characteristics, Functions and Activation

Area of Application / Use Cases

The Symbol File Configurator is an additional tool. If you can already access created symbol files in NCM PC / STEP 7, you do not require the Symbol File Configurator.

You can access existing symbol files and expand or modify them.

Range of Functions of the Symbol File Configurator

The Symbol File Configurator provides the following options:

- Creating your own hierarchical name space
- Setting the properties of a symbol:
 - Visibility in OPC browsing
 - Access rights (readable/writable) for OPC clients
 - Value range of variables to support the “Percent Deadband” OPC functionality
 - Selecting a communication connection (when there are multiple parallel connections to the communication partner).

Note

In the previous version, you could also use the Symbol File Configurator to download data blocks. This functionality is no longer included in the latest version. Use STEP 7 if you want to do this.



How to Start the Symbol File Configurator

You start the Symbol File Configurator from the Windows Start menu:

**Start ► SIMATIC ► SIMATIC NET ► Settings ►
Symbol File Configurator**

Layout

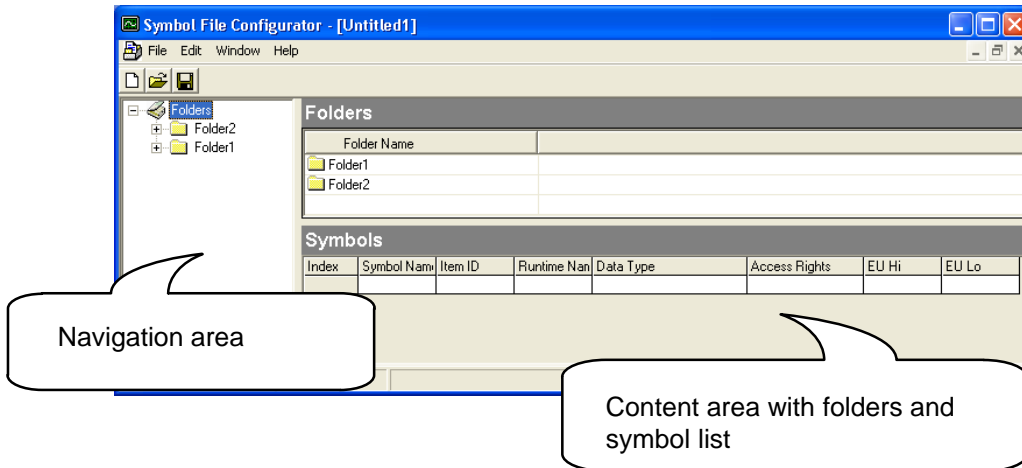

Analogous to the folder and files in the file system, the symbol file contains folders and symbols. In the structure view in the left window, you can navigate through the hierarchy of the symbol file. When you click on a folder there, the right-hand side displays its content. In the upper part of the content area you can see the folders and in the lower part the symbols.

The folders are used to structure your data. The symbols contain the actual information of the process variables such as access rights, data types, and the name of the item and the runtime name.

The symbol list shows the following detailed information:

Parameter	Meaning
Symbol name	The name of the symbol.
Item ID	The names of the hierarchy levels and the symbolic name, separated by a period.
Runtime name	An OPC Item ID with protocol and address information. This runtime name is accepted directly by the OPC Server (in other words without the assignment information of a symbol file).
Data type	Indicates the data type of the symbol.
Access Rights	Indicates whether the data of the symbol can be read or written.



Parameter	Meaning
EU Lo	Indicates the low limit of the range of values of the variable (Engineering Units Low). The information about a range of values is used for the "Percent Deadband" OPC functionality.
EU Hi	Indicates the high limit of the range of values of the variable (Engineering Units High). The information about a range of values is used for the "Percent Deadband" OPC functionality.

Converting Old Symbol Files

Notice

If you have performance problems with old symbol files of the type SSD, we recommend that you convert to the new type STI. This achieves a significant improvement in performance when accessing symbols with OPC.



14.2 The Meaning of Symbols

Definitions

The terms listed below are important in conjunction with the Symbol File Configurator:

Term	Meaning
OPC ItemID	<p>The OPC ItemID is the identifier of a process variable used by the OPC server.</p> <p>An ItemID is transferred by the OPC client to the OPC Server to identify a process variable and is unique for the OPC Server.</p> <p>It is either a symbolic name or a runtime name.</p>
Symbolic name	<p>A symbolic name is an OPC ItemID that was generated by the Symbol File Configurator. In a hierarchically structured name space, a symbolic name is made up of the names of the hierarchical levels and the actual symbol.</p> <p>Example: Plant_Packing.Conveyor.Limit_Switch</p>
Runtime name	<p>A runtime name is an OPC ItemID that contains protocol and address information to allow the assignment and that is accepted directly by the OPC Server without the use of a symbol file. Using the Symbol File Configurator, a symbolic name is assigned to a runtime name.</p> <p>Examples:</p> <ul style="list-style-type: none"> ● DP:[CP.5613]Slave1M003_IB0 ● FMS:[Connection1]14 ● S7:[S7_1.Connection]MW5

Accessing Process Variables using Symbols

An OPC client normally accesses process variables using ItemIDs that contain address information. It is, however, also possible to access the variables using symbolic names that can be structured hierarchically.

These names that are independent of the protocol and device are known as symbols. In contrast, the variable names that include information about the communications path and type in their syntax are known as runtime names.

Example of a symbol: Conveyor_1.drive_1.lim_switch

Example of a runtime name: S7:[Connection_1]EX3.1



When to Use Symbols?

The use of symbolic names is not mandatory. One exception to this is communication over PROFINet or communication with a SIMOTION partner. Here only symbols are used. You can either do without self-defined symbols or add symbols at a later point in time. If you do not require symbols skip to the next step.

Creating and Using Symbol Files

A symbolic name space is created either directly with NCM PC / STEP 7 or using the "Symbol File Configurator" tool.

The Symbol File Configurator program creates a file containing the symbolic hierarchical name space and the assigned runtime names.

The file created by the Symbol File Configurator is entered in the "Configuration Console" program.

A symbol file must "fit in" with the configuration loaded on the PC station. To resolve a symbolic name, the symbol file uses the run-time name. For this reason, if you modify a connection name in the configuration, you must also adapt the symbol file to the change. Otherwise the OPC client will not be able to use the symbol.





14.3 Menus of the Symbol File Configurator in Detail

“File” Menu

This menu contains standardized commands for working with the files (for example, “Open File”, “Save File” etc.). All symbol files have the extension “sti” (**Siemens Tag Info**). The following menu commands are available.

Table 14-1

Menu Command	Meaning
New	Select this menu command to create a new symbol file. Alternatively, you can click the following button: 
Open	Select this menu command to open an existing symbol file. Alternatively, you can click the following button: 
Save	Select this menu command to save an open symbol file in the current folder. Alternatively, you can click the following button: 
Save As ...	Select this menu command to save a symbol file under a new name or in a different folder.
Close	Select this menu command to close a currently open symbol file. Other open files remain open and are not affected by this command.
Exit	Select this menu command to close the Symbol File Configurator and all open files.



“Edit” Menu

This menu contains commands with which you can edit folders and symbols. Here, you will find the essential functions of the tool. In the following sections, you will find a detailed description based on sequences of steps.

Table 14-2

Menu Command	Meaning
New Folder	With this menu command you can create a new folder. When you select the command, a dialog box “Add Folder” appears in which you enter the folder name. A new folder is always created below the icon selected in the left-hand area. Note: The Symbol File Configurator allows a maximum folder nesting depth of 9 and a maximum path length of 255 characters. If these limits are exceeded, in particular when moving folders, problems can occur.
New Symbol	With this menu command, you create new symbols. After selecting the menu command, the “Add Items ...” dialog opens
Add Prefix	You can save a preferred prefix for the OPC name space in your symbol file. This prefix is recommended in the “Configuration Console” configuration program in the “Manage Symbol Files” diagram if a symbol file with a preferred prefix is selected. The prefix precedes the OPC name space of a symbol file, for example when browsing, and is used to identify symbols uniquely if there are several symbol files. If a prefix exists, it is displayed in the folder view.
Remove Element	Select this menu command to delete a folder selected in the left window area.
Import from CSV file	
Export to CSV file	

“Window” Menu

This menu provides commands with which you can change the arrangement of the windows. Here, you also see a list of the currently open symbol files with their paths. The active window (symbol file) is indicated by a check mark.

“Help” Menu

With the help menu, you can open the contents, index, or find views of the help system. You can also display the version number of the program with the “About” menu command.



14.4 Managing Symbols

14.4.1 How to Insert a New Symbol

Activity	
1.	Select a folder in the left-hand area of the program window. The program always creates new symbols below the selected folder.
2.	<p>Select “New Symbol” in the “Edit” menu.</p> <p>or</p> <p>Select “New Symbol” in the context-sensitive menu (right mouse button)</p> <p>The “Add Items” dialog box appears:</p>
3.	<p>In the OPC Address Space area of the window, you can see the variables for all currently active protocols. Select the variable for which you want to assign a symbolic name and then click the button with the arrow pointing to the right (“Add Selection”).</p> <p>Alternatively, you enter the required values in the lower part of the window for manual input.</p>
4.	<p>The variable appears in the Selected Items part of the window. Add a symbolic name here.</p> <p>Repeat steps 3 and 4 when necessary for other variables.</p>
5.	Close the “Add Items” dialog by clicking the “OK” button.

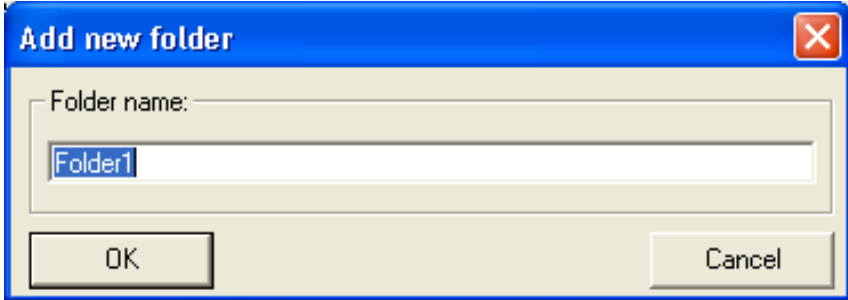

14.4.2 How to Insert a New Folder

Activity	
1.	Select an element in the left-hand area of the program window. The program always creates a new folder below the selected element.
2.	Select the “New Folder” command in the “Edit” menu. or Select “New Folder” in the context-sensitive menu (right mouse button) or Click on the following button: 
3.	The “Insert New Folder” dialog opens. Here, enter a name for the new folder and confirm your entry by clicking the “OK” button. 



14.4.3 How to Add a Name Space Prefix

Activity	
1.	<p>Select "Add/Change Prefix" in the "Edit" menu. The "Change Prefix" dialog appears.</p> 
2.	<p>Here, enter a name for the prefix or change an existing prefix name and confirm your entry by clicking the "OK" button. If you want to delete the prefix, click the "Delete Prefix" button.</p>

14.4.4 How to Delete Folders or Symbols

Activity	
1.	Select the folder or symbol you want to delete in the structure view.
2.	<p>Select "Remove Element" in the "Edit" menu. or Select "Remove Element" in the context-sensitive menu (right mouse button) Remember that when you delete a folder, you also delete all the elements contained in the folder (subfolders and symbols).</p>

14.4.5 How to Import a Symbol File

Activity	
1.	In the OPC Address Space dialog, select the context-sensitive menu "Import from CSV File" . A dialog appears in which you can select a file.
2.	Select the file you want to import and confirm your entries with the "OK" button.



14.4.6 How to Export a Symbol File

Activity	
1.	In the OPC Address Space dialog, select the context-sensitive menu “ Export to CSV File ”. A dialog appears in which you can save a file.
2.	Select a folder and enter a file name. Confirm your entries by clicking the “OK” button.



15 Configuration Console Tool

The Configuration Console is a snap-in program embedded in the Microsoft Management Console (MMC) and provides a wide range of options for configuring PC hardware components and PC user programs as well as providing diagnostic functions.

Settings for the OPC servers that ship with the communication software can also be made in the Configuration Console.

The "Configuration Console" supports the following tasks in the communications system of a SIMATIC PC station:

- Commissioning and operation
- Editing the configuration
- Diagnostics

15.1 Characteristics, Function and Activation

How to Start the Configuration Console

Select the following from the Start menu of the Windows operating system:

Programs ▶ SIMATIC NET ▶ Settings ▶ Configuration Console



Layout

In the Configuration Console, you navigate in basically the same way as in the Windows Explorer.

You navigate on the left-hand side. On the right-hand side, the input/output area, you will see the properties of the selected element (properties object).

The elements in the navigation area are grouped as follows:

- Applications - The OPC Server is displayed as a special application.
- Modules
- Access points

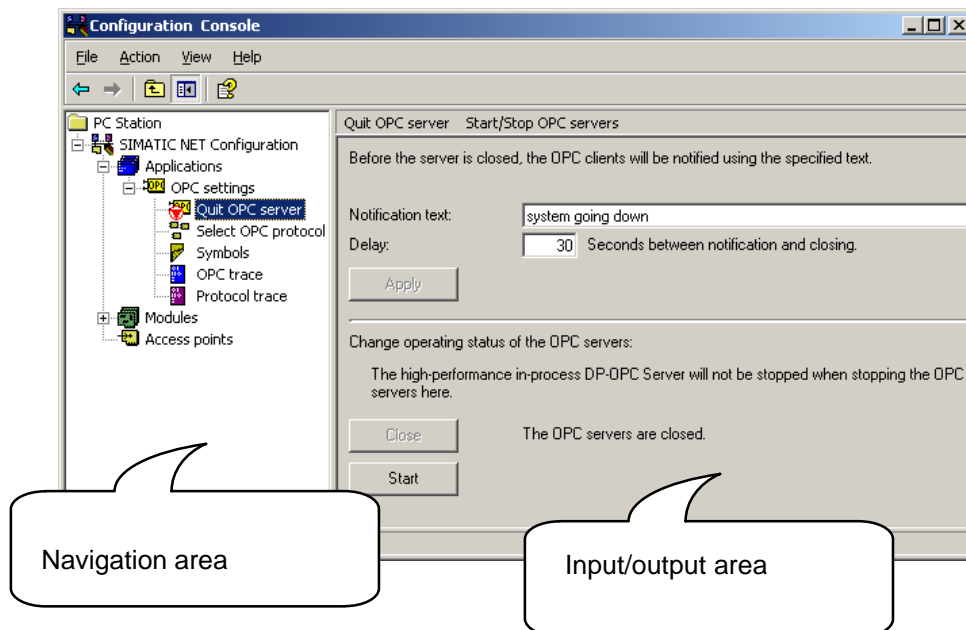



15.2 Support During Commissioning and Operation

Overview

The essential functions provided by the “Configuration Console” tool for commissioning and operation are as follows:

- Configure and set the traces for OPC and protocols
- Deactivate the protocols to commission the system gradually
- Set the symbol files for OPC
- Force the OPC Server to shut down (for example, when an OPC application is no longer reacting)
- Triggering a Restart on the Module

These options are described in the following sections 15.2.1 to 15.2.5.

15.2.1 Triggering a Restart on the Module

The module is reset and the drivers, firmware, and databases are reloaded.

Notice

A restart is possible only when the module is not currently communicating.

**If you want to trigger a restart on the module.....**

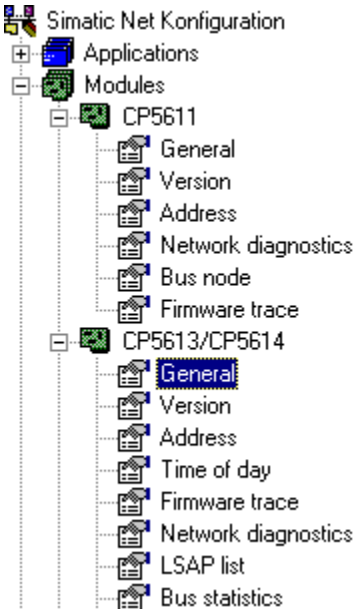
Activity	
1	<p>Open the “Modules” folder in the navigation area. Select the relevant module. Double-click on the “General” property object.</p>  <ul style="list-style-type: none">Simatic Net Configuration<ul style="list-style-type: none">ApplicationsModules<ul style="list-style-type: none">CP5611<ul style="list-style-type: none">GeneralVersionAddressNetwork diagnosticsBus nodeFirmware traceCP5613/CP5614<ul style="list-style-type: none">GeneralVersionAddressTime of dayFirmware traceNetwork diagnosticsLSAP listBus statistics



Activity

2 Click the "Restart" button.
If currently possible, the module is reset. The result of the restart is displayed in the text box.

Type of module:

Mode of the module:

Interface profile for: CP5613/CP5614

CP5613_5614(PROFIBUS) <Active>

CP5613_5614(MPI)

CP5613_5614(Fw/L)

CP5613_5614(Auto)

15.2.2 Forcing the OPC Server to Close Down

The OPC server for SIMATIC NET is started automatically by the operating system when a client wants to use it. The OPC server maintains reference counters to be able to recognize when the last registered client is closed. The OPC Server then closes itself down. This is only possible when the clients set and reset the user counters of the OPC Server correctly.

If a client closes down irregularly and the user counter is not reset, the OPC server will not close down although no more clients are active. The server continues to keep the communication connections open.

In this case, it is a good idea to stop the OPC server manually.

**If you want to close down the or restart OPC server**

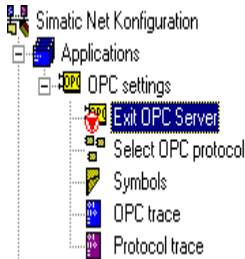
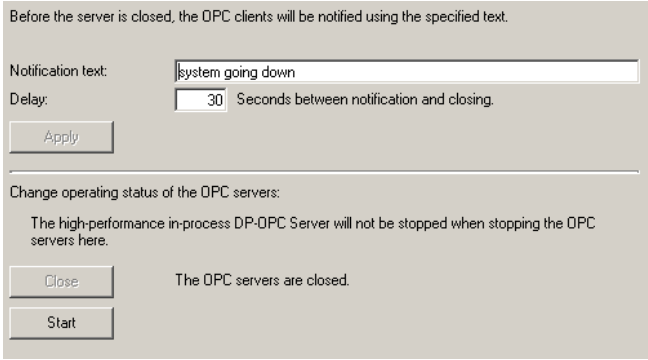
Activity	
1	<p>Open the “Applications” folder in the navigation area. Select “OPC Settings”. Click on the “Exit OPC Server” property object.</p> 
2	<p>If you want to send a notification text to the OPC clients about the close down over the OPC Server, you can enter this in the “Notification text” field. You can also specify a wait time between the notification of the clients and shutting down the server to allow a client to react. Enter this time in the “Delay” box.</p> 
3	<p>Click the “Apply” button to activate the changes you made. Depending on the current operating mode, you can either close or start the OPC server. This applies to both an active OPC Data Access server as well as to an Alarms & Events server. You should first close all OPC clients, otherwise you must expect error messages from the clients.</p>



15.2.3 Activating Configured Protocols Step by Step

By configuring a DP master system and connections, you specify which protocols will be used by the OPC Server.

During the commissioning of a system, it is sometimes useful to commission the protocols individually one after the other. With the procedure described below, you can first deactivate the configured protocols and then activate them again step by step.

If you change the configuration, the manual protocol selection will be replaced by the automatic selection again.

Follow the steps below to activate the configured protocols step by step.....

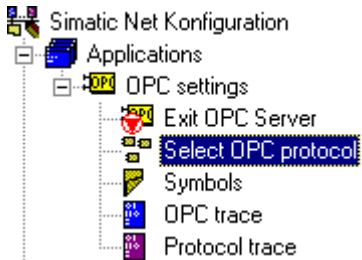
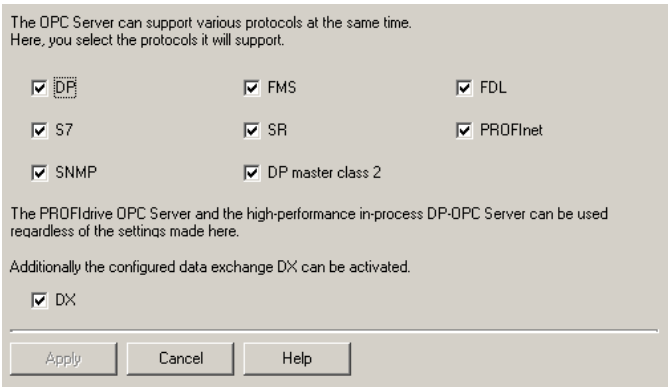
Activity	
1	<p>Open the “Applications” folder in the navigation area. Select “OPC Settings”. Click on the “Select OPC protocol” property.</p> 
2	<p>As default, all protocols are activated. Deactivate the protocols you do not want the OPC Server to use. Activate the protocols that were specified in the configuration and that you want to use as of now.</p> 
3	<p>“Apply” the settings.</p>



Notice

When you download a configuration, all protocols configured in the project engineering are activated automatically, even if you had deactivated them previously. If necessary, you must also deactivate such protocols again.

Note

By deactivating protocols you restrict the range of functions and possibly also the operability of the PC station, the SIMATIC NET Information Service therefore notifies you of this setting!



15.2.4 Setting a Symbol File for OPC

Note

The following information relates to the “Configuration Console” program of the SIMATIC NET software as of Version 6.1.

If you want to use a symbol file for the OPC Server...

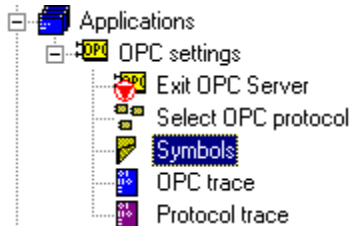
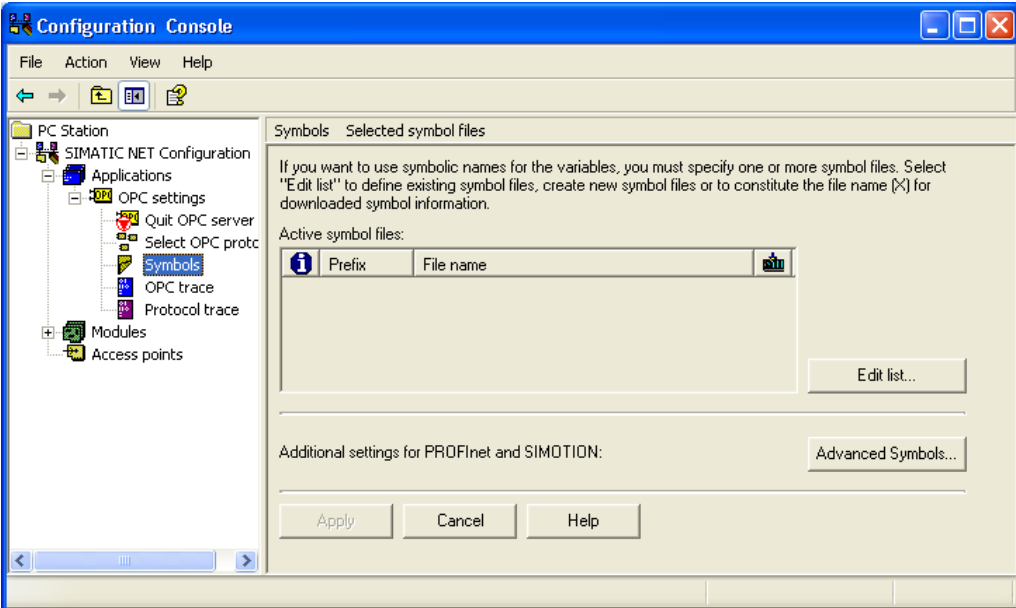
Activity	
1	<p>Open the “Applications” folder in the navigation area. Open the “OPC settings” folder. Select “Symbols”.</p> 
2	<p>Click on the “Edit list...” button to select one or more symbol files:</p> 
3	<p>The “Manage Symbol Files” dialog box opens. Click the “Browse...” button. A file selection dialog opens. Select the required symbol file. Close the “Manage Symbol Files” dialog box by clicking the “OK” button.</p>

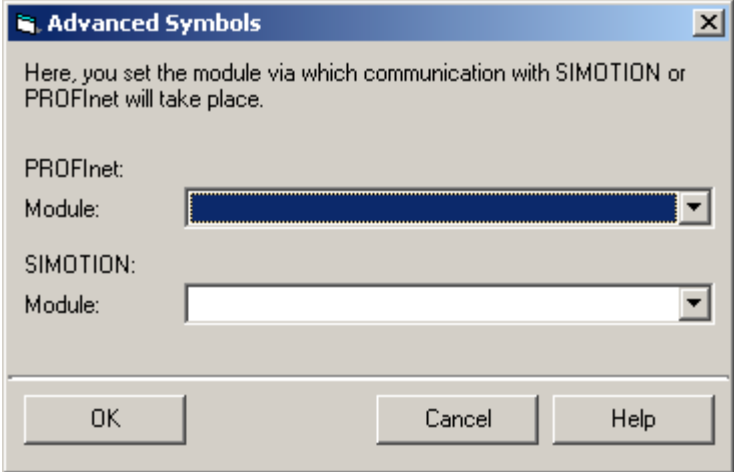

Activity	
4	<p>Additional Settings for PROFINet and SIMOTION.</p> <p>If you use a symbol file created by the engineering tools for PROFINet or SIMOTION, you must also select a module for the communication paths.</p> <p>Click on the “Advanced Symbols...” button</p> <p>Note: It is only necessary to make settings in advanced symbols if the “S7_extended” attribute was set during configuration of the PROFINet data blocks. In this case, the S7 protocol must also be selected. Extended S7 functionality is then used alongside PROFINet. If this functionality is not used, the setting in advanced symbols is irrelevant.</p>
5	<p>If you require this communication, set the following: For PROFINet, select the required Ethernet module. For SIMOTION, select a PROFIBUS module.</p>  <p>Note: For communication with SIMOTION or PROFINet, you only need to set a symbol file and select a module and no further configuration with SIMATIC NCM PC or SIMATIC STEP 7 is necessary. You should also check whether or not the “PROFINet” protocol is enabled on the “OPC Protocol Selection” property page.</p>
6	<p>“Apply” the settings.</p>



15.2.5 Setting Traces

A trace logs the internal sequences of the component. It allows you to check the functions, for example of a user program. Depending on the configuration, the actions of a software module are logged in a file.

The following traces are available:

- Traces of the OPC Servers for Data Access and Alarms&Events
- Trace of the protocol adapters of the OPC Servers
- Trace of the protocol libraries

Notice

In normal operation, the trace should be deactivated since the creation of trace files significantly reduces the speed at which programs are executed. You should also bear in mind that the reduction in speed caused by the trace may result in other problems such as timeouts.

The SIMATIC NET Information Service signals the activation of a trace so that the user is immediately aware of the reduced performance.

If you want to set the traces for the OPC Server or the protocol adapters.....

Activity

1 Open the “Applications / OPC settings” folder in the navigation area.
Double-click on the “OPC trace” property object.

Protocol	Trace target	Trace file	Max. trace entries	Trace depth	Trace gr
DP	No trace	G:\Progr...	10000	Error	All
S7	No trace	G:\Progr...	10000	Error	All
SR	No trace	G:\Progr...	10000	Error	All
FDL	No trace	G:\Progr...	10000	Error	All
FMS	No trace	G:\Progr...	10000	Error	All
PROFINet	No trace	G:\Progr...	100000	Error	All
SNMP	No trace	G:\Progr...	100000	Error	All
DP master class 2	No trace	G:\Progr...	10000	Error	All
PROFIdrive	No trace	G:\Progr...	10000	Error	All
CFG	No trace	G:\Progr...	10000	Error	All
CFG-Service	No trace	G:\Progr...	10000	Error	All
TagInfo	No trace	G:\Progr...	10000	Error	All
Data	No trace	G:\Progr...	5000	No trace	All
DX	No trace	G:\Progr...	5000	No trace	All
Data Inproc DP	No trace	G:\Progr...	5000	No trace	All
Data PROFIdrive	No trace	G:\Progr...	5000	No trace	All

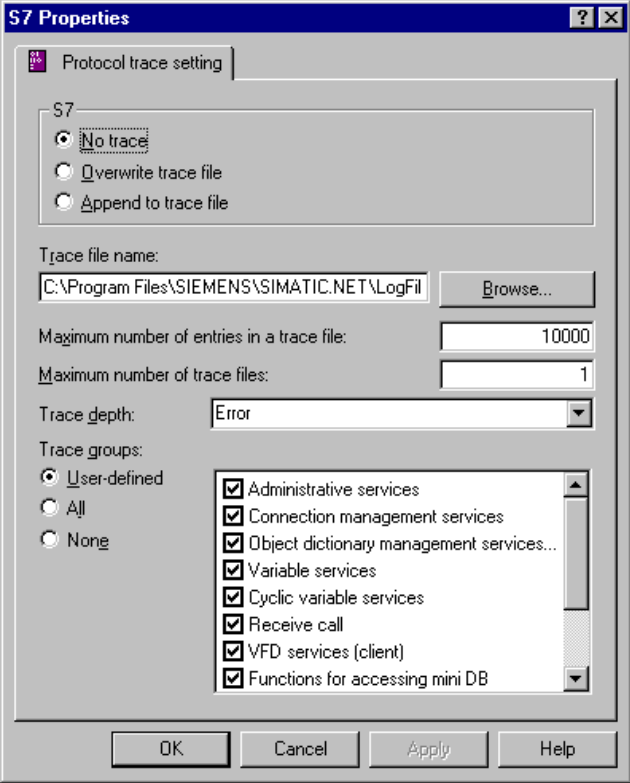

Activity	
2	<p>The table lists the possible traces for the protocols and the OPC Servers in the input/output area.</p> <p>Double-click on a protocol or an OPC server, for example on "PROFIdrive" to open the OPC Server for PROFIdrive.</p> 
3	<p>Activate the trace and select the trace depth.</p> <p>Select "Errors" for example to log information about errors and exceptions.</p>
4	<p>"Apply" the settings.</p>

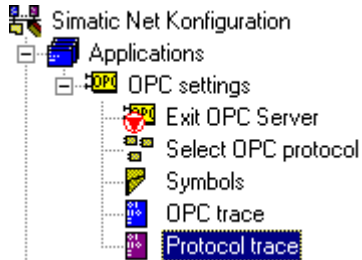

If you want to create traces of the protocol libraries.....

Activity																															
1	<p>Open the “Applications” folder in the navigation area. Open the “OPC settings” folder in the navigation area. Double-click on the “Protocol trace” property.</p> 																														
2	<p>The table lists the traces for the protocol libraries. The protocol libraries for the protocols DP, S7, FMS, SR etc. are not only used by the protocol adapters of the OPC Server but can also be used directly by other user programs.</p> <table border="1" data-bbox="459 952 1120 1126"> <thead> <tr> <th>Protocol</th> <th>Trace target</th> <th>Trace file</th> <th>Trace depth</th> <th>Trace groups</th> </tr> </thead> <tbody> <tr> <td>S7</td> <td>No trace</td> <td>H:\Progr...</td> <td>Error</td> <td>ADMIN CONN VAR. CYCL_VAR RECEI...</td> </tr> <tr> <td>FMS</td> <td>No trace</td> <td>H:\Progr...</td> <td>Error</td> <td>ADMIN CRL CONN OD VAR. VFD RECEI...</td> </tr> <tr> <td>SR</td> <td>No trace</td> <td>H:\Progr...</td> <td>Error</td> <td>All</td> </tr> <tr> <td>DP</td> <td>No trace</td> <td>H:\Progr...</td> <td>All</td> <td>All</td> </tr> <tr> <td>ISOon...</td> <td>No trace</td> <td>H:\Progr...</td> <td>All</td> <td>Error Warnings</td> </tr> </tbody> </table>	Protocol	Trace target	Trace file	Trace depth	Trace groups	S7	No trace	H:\Progr...	Error	ADMIN CONN VAR. CYCL_VAR RECEI...	FMS	No trace	H:\Progr...	Error	ADMIN CRL CONN OD VAR. VFD RECEI...	SR	No trace	H:\Progr...	Error	All	DP	No trace	H:\Progr...	All	All	ISOon...	No trace	H:\Progr...	All	Error Warnings
Protocol	Trace target	Trace file	Trace depth	Trace groups																											
S7	No trace	H:\Progr...	Error	ADMIN CONN VAR. CYCL_VAR RECEI...																											
FMS	No trace	H:\Progr...	Error	ADMIN CRL CONN OD VAR. VFD RECEI...																											
SR	No trace	H:\Progr...	Error	All																											
DP	No trace	H:\Progr...	All	All																											
ISOon...	No trace	H:\Progr...	All	Error Warnings																											

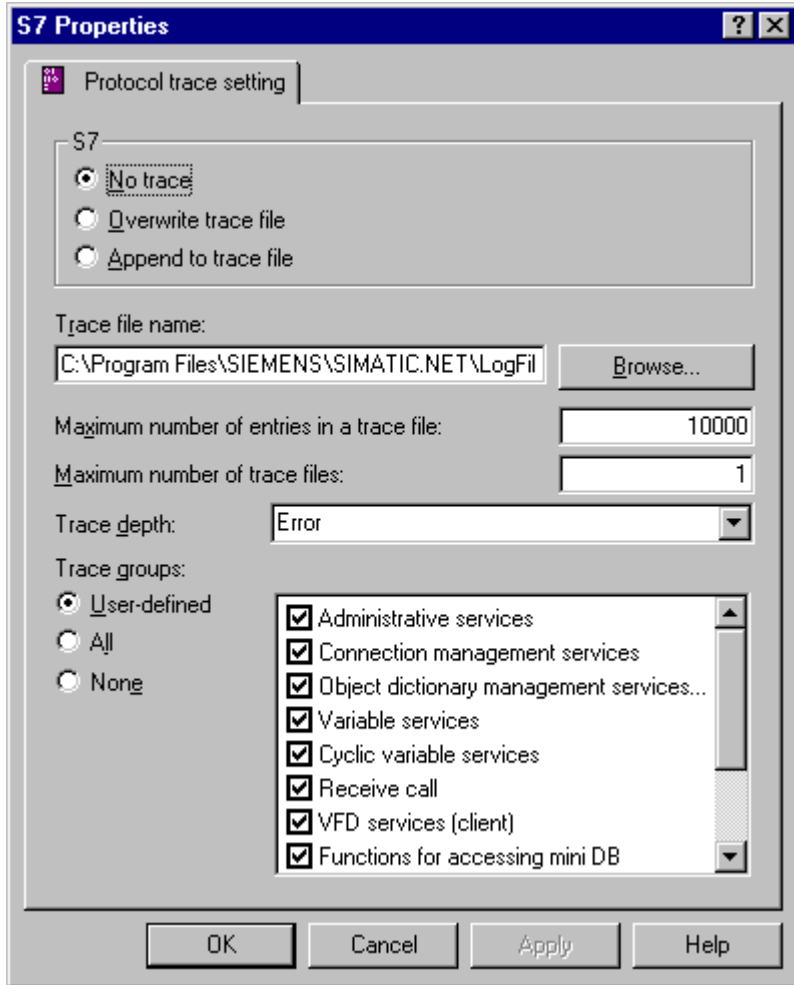

Activity	
3	<p>Double-click on a protocol, for example, on “S7” for the trace settings of SAPI S7. The corresponding Properties dialog box opens.</p> 
4	Activate the trace by setting the first option box to “Overwrite trace file” or “Append to trace file”.
5	“Apply” the settings.



15.3 Editing the Configuration

Overview

During configuration you can do the following:

- Change the mode of the module and set the index
- Set the Industrial Ethernet network parameters
- Set the Industrial Ethernet station addresses for the CP 1613
- Assign the application access points to the individual modules
- Set the PROFIBUS DP slave mode

These options are described in the following sections 15.3.1 to 15.3.5.

15.3.1 Changing the Mode of a Module

When you first commission a module (initial configuration), the mode is specified by using the Station Configuration Editor.

Under some circumstances, it may be useful to change the operating mode of the module:

- If you want to use the module for other purposes
- If the bus parameters of the network were changed and you want to adapt the module to these parameters
- If you want to process the module again with the Commissioning Wizard

If you want to change the operating mode of a module.....

Activity	
1	<p>Open the "Modules" folder in the navigation area. Select the required module. Double-click on the "General" property object.</p> 

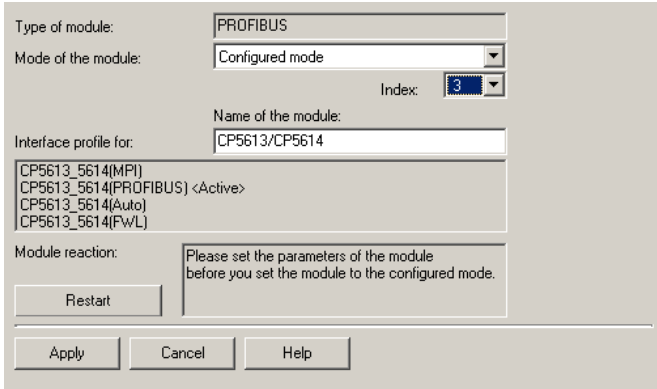

Activity	
2	<p>Select the mode you want to use for the module:</p> <ul style="list-style-type: none">● Configured mode The parameters for the module are set in the project engineering data.● PG Operation The parameters for the module are set in the “Set PG/PC Interface” or Configuration Console program. <div style="text-align: center;"></div>
3	<p>Set the index that must also match the index in the defined configuration. Use the value from the defined configuration if this already exists. Otherwise you must use the value selected here when you create the defined configuration.</p> <p>If you changed from another mode to the “configured mode”, you can also set the index. We recommend that you use the default.</p>
4	<p>“Apply” the set values.</p>



15.3.2 Displaying and Setting the Industrial Ethernet Network Parameters for a CP 1613

For the Industrial Ethernet module CP 1613, the current settings are displayed and can be modified for the following functions:

- duplex mode (half duplex, full duplex, automatic)
- medium type (AUI, TP, automatic)
- transmission rate (10 Mbps, 100 Mbps, automatic)

Three sets of option buttons are available with which the user can select the duplex mode (half duplex, full duplex, automatic), the type of transmission medium (AUI, TP, automatic) and the transmission rate (10 Mbps, 100 Mbps, automatic). The default value for these three parameters is "Automatic". After changing the settings, you will be prompted to restart the driver.

Notice

If you select AUI as the medium type, you can no longer change the options for the transmission rate and duplex mode. In this case, 10 Mbps and half duplex are set. If, on the other hand, 100 Mbps or full duplex are selected, AUI can no longer be selected as the transmission medium.

Current Setting

Transmission parameters (current setting)

After the CP 1613 starts up, the current transmission parameters are displayed in the relevant boxes. As long as no valid link to the partner is detected, the output box displays "unknown".

**If you want to display and set the Industrial Ethernet network parameters of the CP 1613**

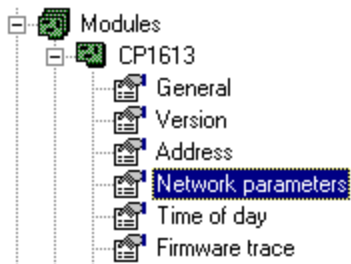
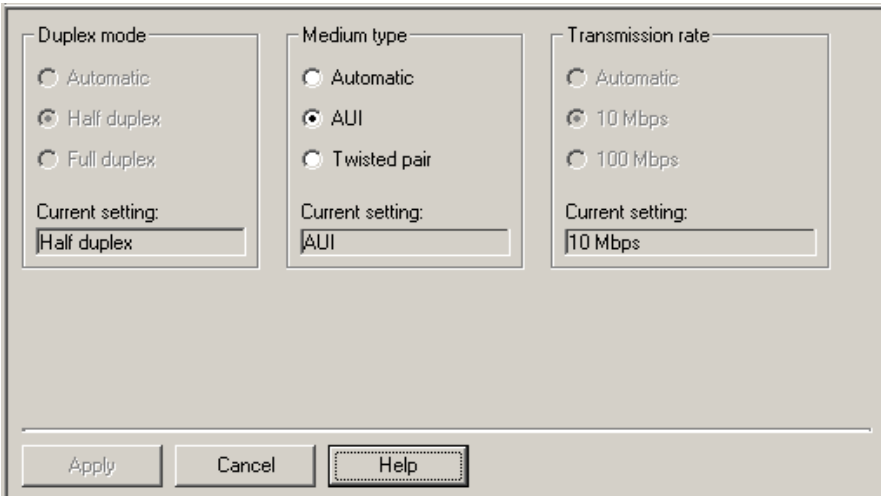
Activity	
1	<p>Open the “Modules” folder in the navigation area. Select the “CP 1613” Ethernet module. Double-click on the “Network parameters” property object.</p> 
2	<p>If you want to modify the network parameters: Activate the required option button for each parameter. The default for all parameters is “Automatic”.</p> 
3	<p>“Apply” the settings. When you apply the values, you will see a message indicating that the module must be restarted before the new values will become effective.</p>
4	<p>If you have installed NDIS1613, you will need to reboot your computer!</p>



15.3.3 Setting the Industrial Ethernet Station Addresses

Note

The modules for SOFTNET Industrial Ethernet are managed by the Windows operating system. This means that the station addresses of these modules must be set with the standard mechanisms of Windows.

If you want to set the Industrial Ethernet station addresses of the CP 1613.....

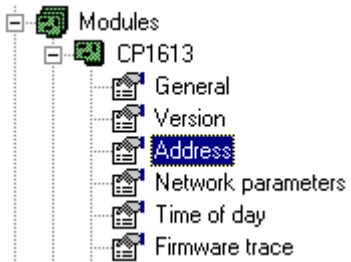
Activity	
1	<p>Open the “Modules” folder in the navigation area. Select a module of the type “CP1613”. Double-click on the “Address” property.</p> 

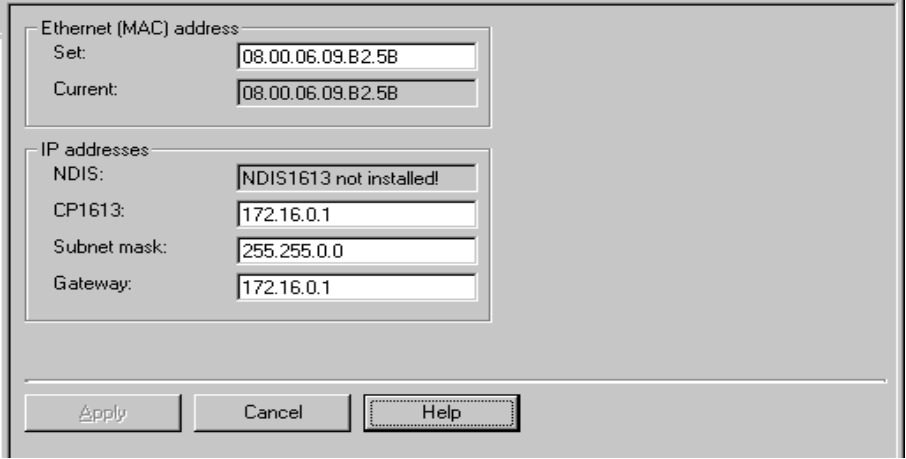

Activity	
2	<p>Depending on the mode set for the module, you can modify or only check the address parameters.</p> <ul style="list-style-type: none">● Configured mode The parameters are set in the project engineering and cannot be changed.● PG Operation The parameters can be changed.  <p>The screenshot shows a configuration dialog box with two main sections. The first section is titled 'Ethernet (MAC) address' and contains two input fields: 'Set:' and 'Current:', both containing the value '08.00.06.09.B2.5B'. The second section is titled 'IP addresses' and contains four input fields: 'NDIS:' with the text 'NDIS1613 not installed!', 'CP1613:' with '172.16.0.1', 'Subnet mask:' with '255.255.0.0', and 'Gateway:' with '172.16.0.1'. At the bottom of the dialog are three buttons: 'Apply', 'Cancel', and 'Help'.</p> <p>If you have selected "PG operation", set the address parameters.</p>
3	<p>"Apply" the set values.</p> <p>When you apply the values, you will see a message indicating that the module must be restarted before the new values will become effective.</p>
4	<p>If you have installed NDIS1613, you will need to reboot your computer!</p>

15.3.4 Assigning Access Points to the Individual Modules

By assigning an access point to an interface parameter assignment, you specify the access path of an application. This assignment is necessary only for applications that use the C interfaces (for example, SAPI S7, SAPI FMS, DP-Lib, SR-Lib) and that use the application access point to address a device.

To operate the OPC server and for applications that handle their communication over configured connections, it is not necessary to assign access points.



If you want to assign an access point of an interface parameter assignment to a module.....

Activity	
1	<p>Open the "Access points" folder in the navigation area.</p>
2	Double-click on the access point you want to edit in the right-hand window.
3	<p>Set the interface parameter assignment to be assigned to the access point.</p> <p>If the module is used in the "configured mode", the active interface parameter assignment is fixed and cannot be modified.</p>
4	"Apply" the settings.

Notice

Important for PROFIBUS modules:

With PROFIBUS modules, only one interface parameter assignment can be activated at any one time. If you select a different interface parameter assignment from the currently active interface parameter assignment when assigning an access point, this interface parameter assignment is activated and assigned to ALL access points!



15.3.5 Setting the PROFIBUS DP Slave

To use the DP slave submodule of the CP 5614/CP 5614FO with OPC, you must configure the submodule as described below. It is not possible to configure these settings in the project engineering data NCM PC / STEP 7.

The slave module configuration is effective only for use with the OPC interface.

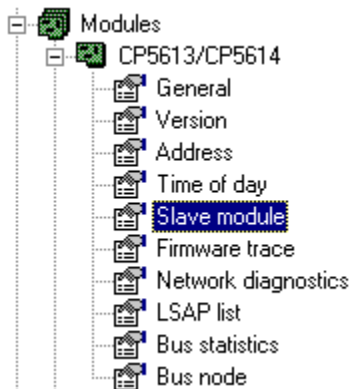
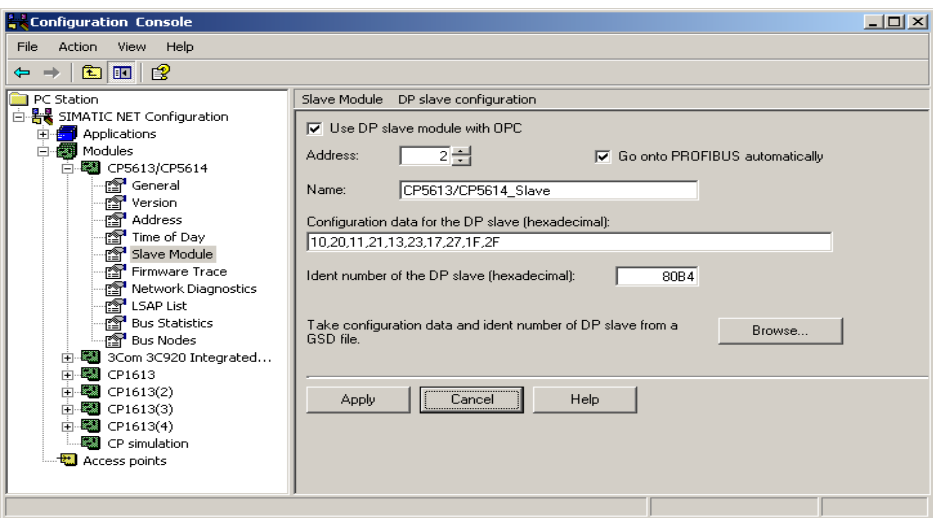
Activity	
1	<p>Open the “Modules” folder in the navigation area. Select the required module of the type “CP 5613/CP 5614 or CP5614A2”. Double-click on the “Slave module” property.</p> 
2	<p>Activate the “Use DP slave module with OPC” check box.</p> 



Activity	
3	<p>Set the remaining properties of the DP slave module as follows:</p> <ul style="list-style-type: none"> ● Use DP slave module with OPC With this check box, you decide whether or not the DP slave module will be used for OPC. ● Address The network address of the DP slave on PROFIBUS. ● Go onto PROFIBUS automatically The slave module goes online immediately after the OPC server starts up and can then be accessed by a DP master. If the check box for this property is not activated, the OPC user program must set the DP slave to online by using the "&devicestate" OPC item. ● Name The name of the slave module that is also used to form the variable name of the OPC items. This name must not be confused with the CP name that must be specified on the C programming interface of the DP slave library. ● Configuration data for the DP slave (hexadecimal) The configuration data for the DP slave are displayed as a list of hexadecimal digits separated by commas and this can be edited. Generally, one pair of digits corresponds to the configuration of a submodule of the DP slave. The coding and submodule properties can be found in the description of the DP Base programming interface. ● Ident number of the DP slave Enter the Ident number of the DP slave as a hexadecimal number. The Ident number is assigned by the PROFIBUS Users Organization and is unique for each slave type. It is also in the GSD file that needs to be created. ● Browse Click the "Browse" button if you want to use a GSD file as a template from which you can also take the Ident number and the configuration data for the DP slave. Please note that with a modular DP slave, only the configuration data of the first submodule definition are adopted.
4	"Apply" the settings.



15.4 Diagnostics with “Configuration Console”

Overview

In diagnostics with “Configuration Console”, you can, for example, do the following

- Display the operability of the modules
- Display the PROFIBUS network parameters
- Display the available network nodes
- Display and set the Industrial Ethernet network parameters
- Display the version information of hardware and software

These options are described in the following sections 15.4.1 to 15.4.5.

15.4.1 Displaying the Operability of a PROFIBUS Module

Follow the steps outlined below...

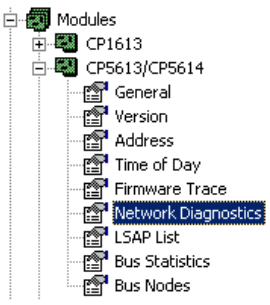
Activity	
1	<p>Open the “Modules” folder in the navigation area. Select the module you want to check. Double-click on the “Network diagnostics” property.</p>  <pre>graph TD Modules[Modules] --> CP1613[CP1613] Modules --> CP5613[CP5613/CP5614] CP5613 --> General[General] CP5613 --> Version[Version] CP5613 --> Address[Address] CP5613 --> TimeOfDay[Time of Day] CP5613 --> FirmwareTrace[Firmware Trace] CP5613 --> NetworkDiagnostics[Network Diagnostics] CP5613 --> LSAPList[LSAP List] CP5613 --> BusStatistics[Bus Statistics] CP5613 --> BusNodes[Bus Nodes]</pre>



Activity

- 2 The bus parameters and the version information of the module are queried and displayed here. By querying the module, the internal communication path is tested. The result of the operation is displayed.

Click the "Test" button again to query the bus parameters.

Network diagnostics

Station Address:

Bus Parameters:

Bus Parameter	Value
Baud rate:	1.5 Mbps
Highest station address (HSA):	126
Min. station delay responder (Min Tsdri):	11 tBit
Max. station delay responder (Max Tsdri):	150 tBit
Setup time (Tset):	1 tBit
Quiet time for modulator (Tqui):	0 tBit
Slot time (tSlot):	300 tBit
Gap update factor:	10
Retru limit:	1

Version:



15.4.2 Displaying the Industrial Ethernet Network Parameters for a CP 1613

For the Industrial Ethernet module CP 1613, the following current settings are displayed

- duplex mode (half duplex, full duplex, automatic)
- medium type (AUI, TP, automatic)
- transmission rate (10 Mbps, 100 Mbps, automatic)

As long as no valid connection to the module is detected, the output fields display the entry “unknown”.

Follow the steps outlined below...

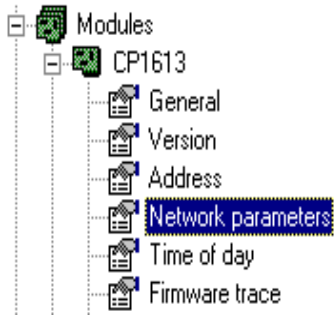
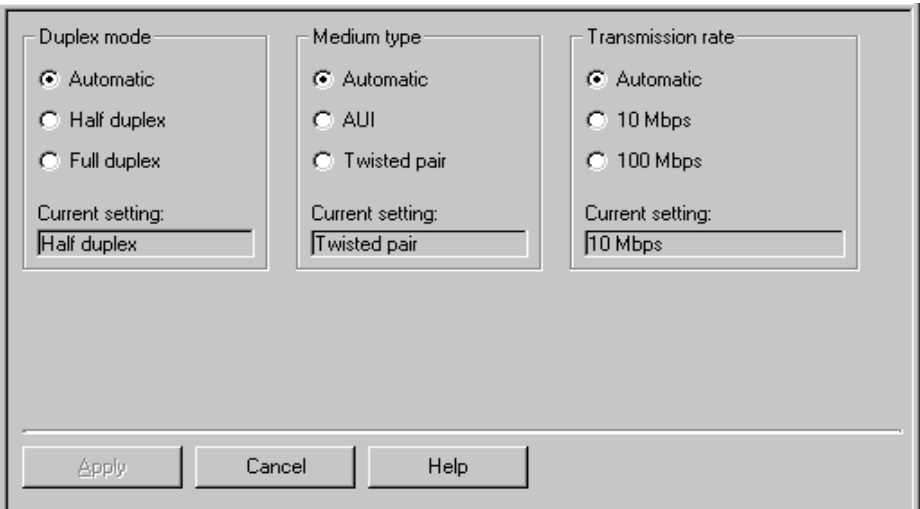
Activity	
1	Open the “Modules” folder in the navigation area. Select the module you want to check. Click on the “Network parameters” property object.
1	
2	



15.4.3 Displaying PROFIBUS Network Nodes

If the module is operational, a list with all the nodes on the bus is created after starting this function.

If the module is currently communicating and the module supports the function, the list of bus parameters is created from local information of the module.

If the module is not currently communicating or the module does not support the creation of a local list, the station addresses are queried over the network.

This creates load on the bus and can take several seconds.

Follow the steps outlined below...

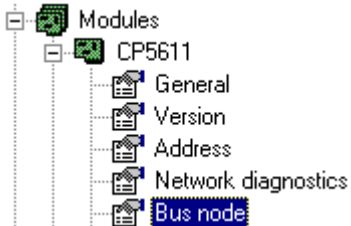
Activity	
1	<p>Open the "Modules" folder in the navigation area. Select the relevant module. Click on the "Bus nodes" property object.</p> 



Activity																																																																																																																																																																																	
2	<p>After the call, the bus nodes are queried and displayed.</p> <p>Four different symbols are used to indicate the operating mode of a station:</p> <ul style="list-style-type: none">● Empty box with gray background (the same background color as tabs): No partner device found● Empty box with bright background: Passive station (for example DP slave)● Check mark on bright background: Active station (for example DP master)● Check mark on gray background: Active station ready to enter network <div style="border: 1px solid gray; padding: 10px; margin: 10px 0;"><p>Bus node</p><table border="1" style="width: 100%; border-collapse: collapse;"><tr><td></td><td>0</td><td>1</td><td>2</td><td>3</td><td>4</td><td>5</td><td>6</td><td>7</td><td>8</td><td>9</td><td>10</td><td>11</td><td>12</td><td>13</td><td>14</td><td>15</td><td>16</td><td>17</td><td>18</td><td>19</td></tr><tr><td>0</td><td><input type="checkbox"/></td><td><input type="checkbox"/></td><td><input type="checkbox"/></td><td><input type="checkbox"/></td><td><input checked="" type="checkbox"/></td><td><input type="checkbox"/></td><td><input type="checkbox"/></td><td><input type="checkbox"/></td><td><input type="checkbox"/></td><td><input type="checkbox"/></td><td><input type="checkbox"/></td><td><input type="checkbox"/></td><td><input type="checkbox"/></td><td><input type="checkbox"/></td><td><input type="checkbox"/></td><td><input type="checkbox"/></td><td><input type="checkbox"/></td><td><input type="checkbox"/></td><td><input type="checkbox"/></td><td><input type="checkbox"/></td></tr><tr><td>20</td><td><input type="checkbox"/></td><td><input type="checkbox"/></td><td><input type="checkbox"/></td><td><input type="checkbox"/></td><td><input type="checkbox"/></td><td><input type="checkbox"/></td><td><input type="checkbox"/></td><td><input type="checkbox"/></td><td><input type="checkbox"/></td><td><input type="checkbox"/></td><td><input type="checkbox"/></td><td><input type="checkbox"/></td><td><input type="checkbox"/></td><td><input type="checkbox"/></td><td><input type="checkbox"/></td><td><input type="checkbox"/></td><td><input type="checkbox"/></td><td><input type="checkbox"/></td><td><input type="checkbox"/></td><td><input type="checkbox"/></td></tr><tr><td>40</td><td><input type="checkbox"/></td><td><input type="checkbox"/></td><td><input type="checkbox"/></td><td><input type="checkbox"/></td><td><input type="checkbox"/></td><td><input type="checkbox"/></td><td><input type="checkbox"/></td><td><input type="checkbox"/></td><td><input type="checkbox"/></td><td><input type="checkbox"/></td><td><input type="checkbox"/></td><td><input type="checkbox"/></td><td><input type="checkbox"/></td><td><input type="checkbox"/></td><td><input type="checkbox"/></td><td><input type="checkbox"/></td><td><input type="checkbox"/></td><td><input type="checkbox"/></td><td><input type="checkbox"/></td><td><input type="checkbox"/></td></tr><tr><td>60</td><td><input type="checkbox"/></td><td><input type="checkbox"/></td><td><input type="checkbox"/></td><td><input type="checkbox"/></td><td><input type="checkbox"/></td><td><input type="checkbox"/></td><td><input type="checkbox"/></td><td><input type="checkbox"/></td><td><input type="checkbox"/></td><td><input type="checkbox"/></td><td><input type="checkbox"/></td><td><input type="checkbox"/></td><td><input type="checkbox"/></td><td><input type="checkbox"/></td><td><input type="checkbox"/></td><td><input type="checkbox"/></td><td><input type="checkbox"/></td><td><input type="checkbox"/></td><td><input type="checkbox"/></td><td><input type="checkbox"/></td></tr><tr><td>80</td><td><input type="checkbox"/></td><td><input type="checkbox"/></td><td><input type="checkbox"/></td><td><input type="checkbox"/></td><td><input type="checkbox"/></td><td><input type="checkbox"/></td><td><input type="checkbox"/></td><td><input type="checkbox"/></td><td><input type="checkbox"/></td><td><input type="checkbox"/></td><td><input type="checkbox"/></td><td><input type="checkbox"/></td><td><input type="checkbox"/></td><td><input type="checkbox"/></td><td><input type="checkbox"/></td><td><input type="checkbox"/></td><td><input type="checkbox"/></td><td><input type="checkbox"/></td><td><input type="checkbox"/></td><td><input type="checkbox"/></td></tr><tr><td>100</td><td><input type="checkbox"/></td><td><input type="checkbox"/></td><td><input type="checkbox"/></td><td><input type="checkbox"/></td><td><input type="checkbox"/></td><td><input type="checkbox"/></td><td><input type="checkbox"/></td><td><input type="checkbox"/></td><td><input type="checkbox"/></td><td><input type="checkbox"/></td><td><input type="checkbox"/></td><td><input type="checkbox"/></td><td><input type="checkbox"/></td><td><input type="checkbox"/></td><td><input type="checkbox"/></td><td><input type="checkbox"/></td><td><input type="checkbox"/></td><td><input type="checkbox"/></td><td><input type="checkbox"/></td><td><input type="checkbox"/></td></tr><tr><td>120</td><td><input type="checkbox"/></td><td><input type="checkbox"/></td><td><input type="checkbox"/></td><td><input type="checkbox"/></td><td><input type="checkbox"/></td><td><input type="checkbox"/></td><td><input type="checkbox"/></td><td><input type="checkbox"/></td><td><input type="checkbox"/></td><td><input type="checkbox"/></td><td><input type="checkbox"/></td><td><input type="checkbox"/></td><td><input type="checkbox"/></td><td><input type="checkbox"/></td><td><input type="checkbox"/></td><td><input type="checkbox"/></td><td><input type="checkbox"/></td><td><input type="checkbox"/></td><td><input type="checkbox"/></td><td><input type="checkbox"/></td></tr></table><div style="margin-top: 10px;"><p style="text-align: center;"><input type="button" value="Update"/></p></div><div style="margin-top: 10px;"><p style="text-align: right;">Key</p><table style="width: 100%;"><tr><td><input type="checkbox"/></td><td>passive</td></tr><tr><td><input checked="" type="checkbox"/></td><td>active</td></tr><tr><td><input checked="" type="checkbox"/></td><td>active-ready</td></tr><tr><td><input type="checkbox"/></td><td>does not exist</td></tr></table></div></div> <p style="text-align: center; margin-top: 10px;"><input type="button" value="Help"/></p>		0	1	2	3	4	5	6	7	8	9	10	11	12	13	14	15	16	17	18	19	0	<input type="checkbox"/>	<input type="checkbox"/>	<input type="checkbox"/>	<input type="checkbox"/>	<input checked="" type="checkbox"/>	<input type="checkbox"/>	<input type="checkbox"/>	<input type="checkbox"/>	<input type="checkbox"/>	<input type="checkbox"/>	<input type="checkbox"/>	<input type="checkbox"/>	<input type="checkbox"/>	<input type="checkbox"/>	<input type="checkbox"/>	<input type="checkbox"/>	<input type="checkbox"/>	<input type="checkbox"/>	<input type="checkbox"/>	<input type="checkbox"/>	20	<input type="checkbox"/>	<input type="checkbox"/>	<input type="checkbox"/>	<input type="checkbox"/>	<input type="checkbox"/>	<input type="checkbox"/>	<input type="checkbox"/>	<input type="checkbox"/>	<input type="checkbox"/>	<input type="checkbox"/>	<input type="checkbox"/>	<input type="checkbox"/>	<input type="checkbox"/>	<input type="checkbox"/>	<input type="checkbox"/>	<input type="checkbox"/>	<input type="checkbox"/>	<input type="checkbox"/>	<input type="checkbox"/>	<input type="checkbox"/>	40	<input type="checkbox"/>	<input type="checkbox"/>	<input type="checkbox"/>	<input type="checkbox"/>	<input type="checkbox"/>	<input type="checkbox"/>	<input type="checkbox"/>	<input type="checkbox"/>	<input type="checkbox"/>	<input type="checkbox"/>	<input type="checkbox"/>	<input type="checkbox"/>	<input type="checkbox"/>	<input type="checkbox"/>	<input type="checkbox"/>	<input type="checkbox"/>	<input type="checkbox"/>	<input type="checkbox"/>	<input type="checkbox"/>	<input type="checkbox"/>	60	<input type="checkbox"/>	<input type="checkbox"/>	<input type="checkbox"/>	<input type="checkbox"/>	<input type="checkbox"/>	<input type="checkbox"/>	<input type="checkbox"/>	<input type="checkbox"/>	<input type="checkbox"/>	<input type="checkbox"/>	<input type="checkbox"/>	<input type="checkbox"/>	<input type="checkbox"/>	<input type="checkbox"/>	<input type="checkbox"/>	<input type="checkbox"/>	<input type="checkbox"/>	<input type="checkbox"/>	<input type="checkbox"/>	<input type="checkbox"/>	80	<input type="checkbox"/>	<input type="checkbox"/>	<input type="checkbox"/>	<input type="checkbox"/>	<input type="checkbox"/>	<input type="checkbox"/>	<input type="checkbox"/>	<input type="checkbox"/>	<input type="checkbox"/>	<input type="checkbox"/>	<input type="checkbox"/>	<input type="checkbox"/>	<input type="checkbox"/>	<input type="checkbox"/>	<input type="checkbox"/>	<input type="checkbox"/>	<input type="checkbox"/>	<input type="checkbox"/>	<input type="checkbox"/>	<input type="checkbox"/>	100	<input type="checkbox"/>	<input type="checkbox"/>	<input type="checkbox"/>	<input type="checkbox"/>	<input type="checkbox"/>	<input type="checkbox"/>	<input type="checkbox"/>	<input type="checkbox"/>	<input type="checkbox"/>	<input type="checkbox"/>	<input type="checkbox"/>	<input type="checkbox"/>	<input type="checkbox"/>	<input type="checkbox"/>	<input type="checkbox"/>	<input type="checkbox"/>	<input type="checkbox"/>	<input type="checkbox"/>	<input type="checkbox"/>	<input type="checkbox"/>	120	<input type="checkbox"/>	<input type="checkbox"/>	<input type="checkbox"/>	<input type="checkbox"/>	<input type="checkbox"/>	<input type="checkbox"/>	<input type="checkbox"/>	<input type="checkbox"/>	<input type="checkbox"/>	<input type="checkbox"/>	<input type="checkbox"/>	<input type="checkbox"/>	<input type="checkbox"/>	<input type="checkbox"/>	<input type="checkbox"/>	<input type="checkbox"/>	<input type="checkbox"/>	<input type="checkbox"/>	<input type="checkbox"/>	<input type="checkbox"/>	<input type="checkbox"/>	passive	<input checked="" type="checkbox"/>	active	<input checked="" type="checkbox"/>	active-ready	<input type="checkbox"/>	does not exist
	0	1	2	3	4	5	6	7	8	9	10	11	12	13	14	15	16	17	18	19																																																																																																																																																													
0	<input type="checkbox"/>	<input type="checkbox"/>	<input type="checkbox"/>	<input type="checkbox"/>	<input checked="" type="checkbox"/>	<input type="checkbox"/>	<input type="checkbox"/>	<input type="checkbox"/>	<input type="checkbox"/>	<input type="checkbox"/>	<input type="checkbox"/>	<input type="checkbox"/>	<input type="checkbox"/>	<input type="checkbox"/>	<input type="checkbox"/>	<input type="checkbox"/>	<input type="checkbox"/>	<input type="checkbox"/>	<input type="checkbox"/>	<input type="checkbox"/>																																																																																																																																																													
20	<input type="checkbox"/>	<input type="checkbox"/>	<input type="checkbox"/>	<input type="checkbox"/>	<input type="checkbox"/>	<input type="checkbox"/>	<input type="checkbox"/>	<input type="checkbox"/>	<input type="checkbox"/>	<input type="checkbox"/>	<input type="checkbox"/>	<input type="checkbox"/>	<input type="checkbox"/>	<input type="checkbox"/>	<input type="checkbox"/>	<input type="checkbox"/>	<input type="checkbox"/>	<input type="checkbox"/>	<input type="checkbox"/>	<input type="checkbox"/>																																																																																																																																																													
40	<input type="checkbox"/>	<input type="checkbox"/>	<input type="checkbox"/>	<input type="checkbox"/>	<input type="checkbox"/>	<input type="checkbox"/>	<input type="checkbox"/>	<input type="checkbox"/>	<input type="checkbox"/>	<input type="checkbox"/>	<input type="checkbox"/>	<input type="checkbox"/>	<input type="checkbox"/>	<input type="checkbox"/>	<input type="checkbox"/>	<input type="checkbox"/>	<input type="checkbox"/>	<input type="checkbox"/>	<input type="checkbox"/>	<input type="checkbox"/>																																																																																																																																																													
60	<input type="checkbox"/>	<input type="checkbox"/>	<input type="checkbox"/>	<input type="checkbox"/>	<input type="checkbox"/>	<input type="checkbox"/>	<input type="checkbox"/>	<input type="checkbox"/>	<input type="checkbox"/>	<input type="checkbox"/>	<input type="checkbox"/>	<input type="checkbox"/>	<input type="checkbox"/>	<input type="checkbox"/>	<input type="checkbox"/>	<input type="checkbox"/>	<input type="checkbox"/>	<input type="checkbox"/>	<input type="checkbox"/>	<input type="checkbox"/>																																																																																																																																																													
80	<input type="checkbox"/>	<input type="checkbox"/>	<input type="checkbox"/>	<input type="checkbox"/>	<input type="checkbox"/>	<input type="checkbox"/>	<input type="checkbox"/>	<input type="checkbox"/>	<input type="checkbox"/>	<input type="checkbox"/>	<input type="checkbox"/>	<input type="checkbox"/>	<input type="checkbox"/>	<input type="checkbox"/>	<input type="checkbox"/>	<input type="checkbox"/>	<input type="checkbox"/>	<input type="checkbox"/>	<input type="checkbox"/>	<input type="checkbox"/>																																																																																																																																																													
100	<input type="checkbox"/>	<input type="checkbox"/>	<input type="checkbox"/>	<input type="checkbox"/>	<input type="checkbox"/>	<input type="checkbox"/>	<input type="checkbox"/>	<input type="checkbox"/>	<input type="checkbox"/>	<input type="checkbox"/>	<input type="checkbox"/>	<input type="checkbox"/>	<input type="checkbox"/>	<input type="checkbox"/>	<input type="checkbox"/>	<input type="checkbox"/>	<input type="checkbox"/>	<input type="checkbox"/>	<input type="checkbox"/>	<input type="checkbox"/>																																																																																																																																																													
120	<input type="checkbox"/>	<input type="checkbox"/>	<input type="checkbox"/>	<input type="checkbox"/>	<input type="checkbox"/>	<input type="checkbox"/>	<input type="checkbox"/>	<input type="checkbox"/>	<input type="checkbox"/>	<input type="checkbox"/>	<input type="checkbox"/>	<input type="checkbox"/>	<input type="checkbox"/>	<input type="checkbox"/>	<input type="checkbox"/>	<input type="checkbox"/>	<input type="checkbox"/>	<input type="checkbox"/>	<input type="checkbox"/>	<input type="checkbox"/>																																																																																																																																																													
<input type="checkbox"/>	passive																																																																																																																																																																																
<input checked="" type="checkbox"/>	active																																																																																																																																																																																
<input checked="" type="checkbox"/>	active-ready																																																																																																																																																																																
<input type="checkbox"/>	does not exist																																																																																																																																																																																
3	<p>Click the "Update" button again to access the module and query the bus nodes.</p>																																																																																																																																																																																



15.4.4 Displaying PROFIBUS Network Parameters

Follow the steps outlined below...

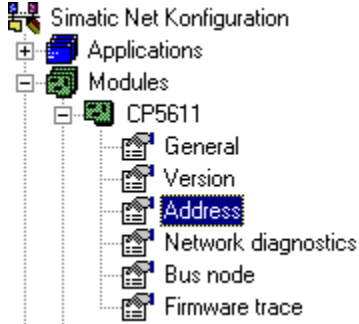
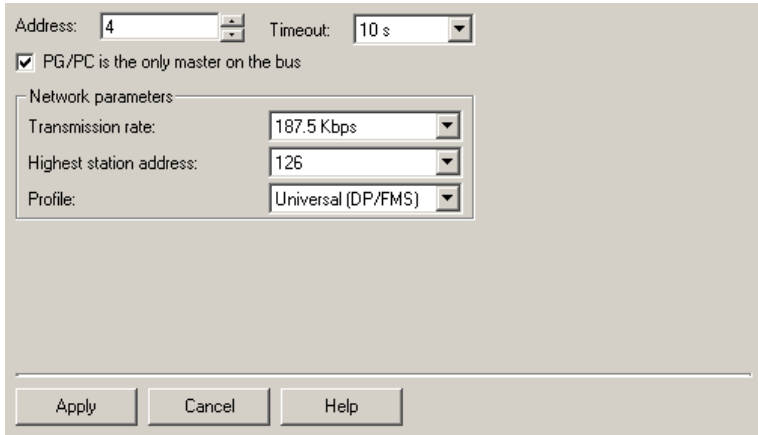
Activity	
1	<p>Open the “Modules” folder in the navigation area. Select the relevant PROFIBUS module. Click on the “Address” property object.</p> 
2	<p>After the call, the address parameters set for the module are displayed.</p> <ul style="list-style-type: none"> ● Timeout <p>Here, you can set the connection monitoring time for the CP 5511 / CP 5512 / CP 5611. Increase the connection timeout, for example, if you have problems with high response times in the network.</p> 



15.4.5 Displaying Version Information of Hardware and Firmware

Follow the steps outlined below...

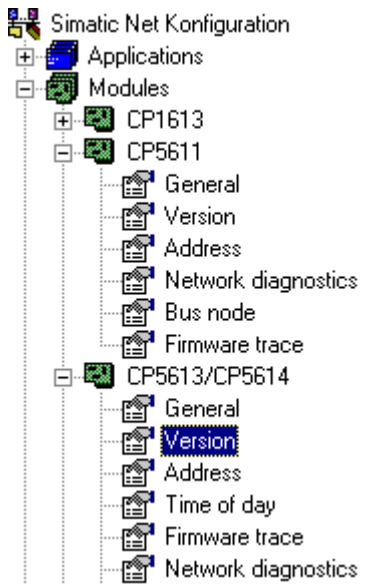
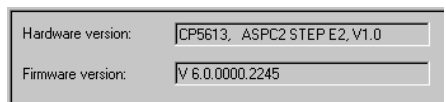
Activity					
1	<p>Open the “Modules” folder in the navigation area. Select the relevant module. Click on the “Version” property object.</p>  <ul style="list-style-type: none">Simatic Net Konfiguration<ul style="list-style-type: none">ApplicationsModules<ul style="list-style-type: none">CP1613CP5611<ul style="list-style-type: none">GeneralVersionAddressNetwork diagnosticsBus nodeFirmware traceCP5613/CP5614<ul style="list-style-type: none">GeneralVersionAddressTime of dayFirmware traceNetwork diagnostics				
2	<p>After the call, version information about the communication module is displayed.</p>  <table border="1"><tr><td>Hardware version:</td><td>CP5613, ASPC2 STEP E2, V1.0</td></tr><tr><td>Firmware version:</td><td>V 6.0.0000.2245</td></tr></table>	Hardware version:	CP5613, ASPC2 STEP E2, V1.0	Firmware version:	V 6.0.0000.2245
Hardware version:	CP5613, ASPC2 STEP E2, V1.0				
Firmware version:	V 6.0.0000.2245				



16 OPC Scout

With the OPC Scout, you can test an OPC application or commission the OPC server.

The following description assumes that you are familiar with the terminology and mechanisms of OPC (OPC server and OPC client). You will find basic and detailed information on this topic in the Industrial Communication with PG/PC manual /1/.

16.1 Characteristics, Functions and Activation

Which functions does the OPC Scout provide?

Table 16-1

Steps / Functions	Meaning
Connecting the OPC Scout to a local server	Before you can work with the OPC Scout, you must connect the OPC Scout with an OPC server.
Connecting the OPC Scout to a remote server	Alternatively to connecting to a local server, you can connect the OPC Scout with an OPC Server running on a remote computer using DCOM.
Create a group	You initially create groups with which you can manage the items.
Browsing the process space	You can browse the process space of the OPC server in the OPC Navigator window.
Creating new variables	In the OPC Navigator window, you can create new variables and specify which variables will be monitored.
Adding and monitoring variables	Add the variables you want to monitor to the current group.
Customizing the display	You can decide what information is displayed for variables in the OPC Scout window.
Display attributes	You can display the attributes of individual OPC items.
Change values	Using the OPC Scout you can modify the values of writable variables directly.

The following description will familiarize you with the user interface of the OPC scout. Step by step, it shows you how to use the functions described above.



How to Start the OPC Scout

You start the OPC Scout from the Start menu of the Windows operating system:

Programs ► SIMATIC NET ► PROFIBUS ► CP5613_5614 ► OPC Scout (or in the part of the Start menu in your product)

The OPC Scout appears as follows:

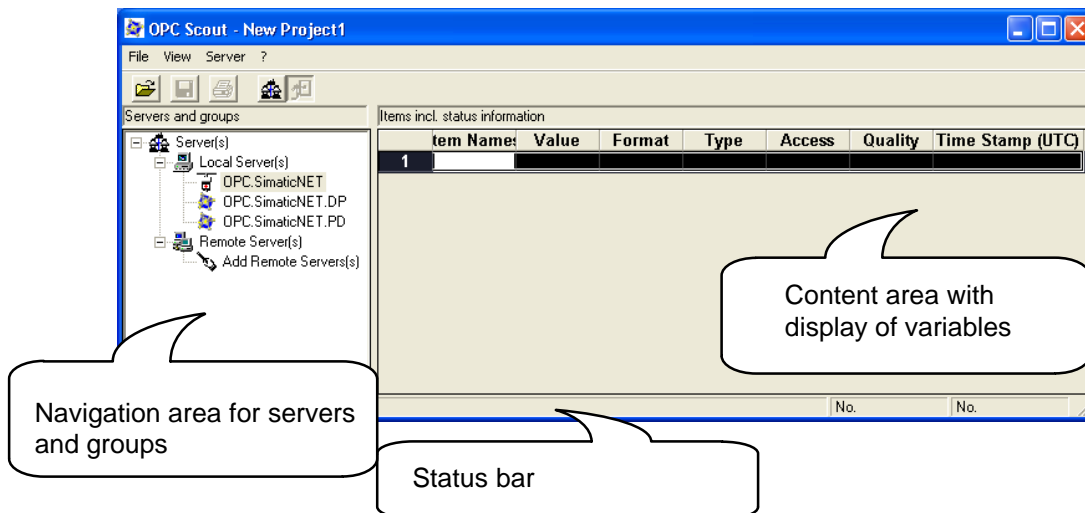

Depending on the activities you perform during the session, the OPC Scout can have the following menus:

The menu	contains commands relating to the following topics
File	You can load, save and print projects and items.
View	You can modify the appearance of the OPC Scout user interface.
Server	You can connect the OPC Scout to a server and display server properties.
Group	You can add and delete groups and assign items.
Item	You can add and delete OPC items and edit the values of the items.
?	You can display help.



The OPC Scout supports context-sensitive menus!

Click on an object and then try out the right mouse button. You will then see a menu in which you can select the functions that are possible with the selected object.



16.2 Connecting the OPC Scout to a Local Server

Before you can work with the OPC Scout, you must connect the OPC Scout with a server.

Activity	
1.	In the Server and Groups Navigator open the Server ► Local Server(s) entry.
2.	Select one of the following OPC server types: <ul style="list-style-type: none"> ● OPC.SimaticNET (standard OPC server of SIMATIC NET) ● OPC.SimaticNET.DP (high-performance DP inproc server) ● OPC.SimaticNET.PD (PROFIDrive OPC server)
3.	Open the Server menu and select the Connect menu command. The OPC Scout is connected to the local OPC Server for SIMATIC NET. A dialog for creating a group opens.

16.3 Connecting the OPC Scout to a Remote Server

Alternatively to connecting to a local server, you can connect the OPC Scout with an OPC Server running on a remote computer using DCOM.

Note

Note that for access to a remote computer, operation with DCOM must be configured.

Activity	
1.	In the Server and Groups Navigator open the Server ► Remote Server(s) entry.
2.	Double-click the Add Remote Server entry. A dialog box opens.
3.	Enter the node name of the remote computer and the ProgID of the OPC server in the dialog. For the OPC server of SIMATIC NET, enter "OPC.SimaticNET".
4.	Close the dialog with the OK button.
5.	Select the remote server with which you want to connect the OPC Scout.
6.	Open the Server menu and select the Connect menu command. The OPC Scout is connected to the remote OPC server. A dialog for creating a group opens.



16.4 Create a Group

You must first create one or more groups in which you can then manage the items you want to monitor or control.

Activity	
1.	Open the Group menu and select the Add Group menu command or click on [New Group] in the Navigator window. The Add Group window opens.
2.	Enter the new group name.
3.	Select the Generate new active group box to activate the group.
4.	In the Transmission interval in ms box, enter how often values of the variables will be updated.
5.	Optional: Open the expanded dialog You can also set the range of fluctuation (dead zone in %) for value changes within which the value is not updated. Select the "Expanded" option and set the dead zone in %.
6.	Click the OK button. The Add Group window is closed, the group is inserted in the server and therefore also in the Server and Group Navigator of the main window of the OPC Scout.

16.5 Browsing the Process Space - OPC Navigator

You can browse the process space of the OPC server in the **OPC Navigator** window. In the **OPC Navigator** window, you can then create new variables and specify which variables will be monitored.



Activity	
1.	Select the required group for which you want to browse the process space of the server in the Servers and Groups Navigator of the OPC Scout.
2.	Open the Item menu and select the Add Item(s) command. The OPC Navigator window opens. The left-hand column of the window displays the hierarchical structure of the process space. You can double-click to open the lower levels.
3.	Select the level for which you want to display variables. All the variables for the level are displayed in the middle column.

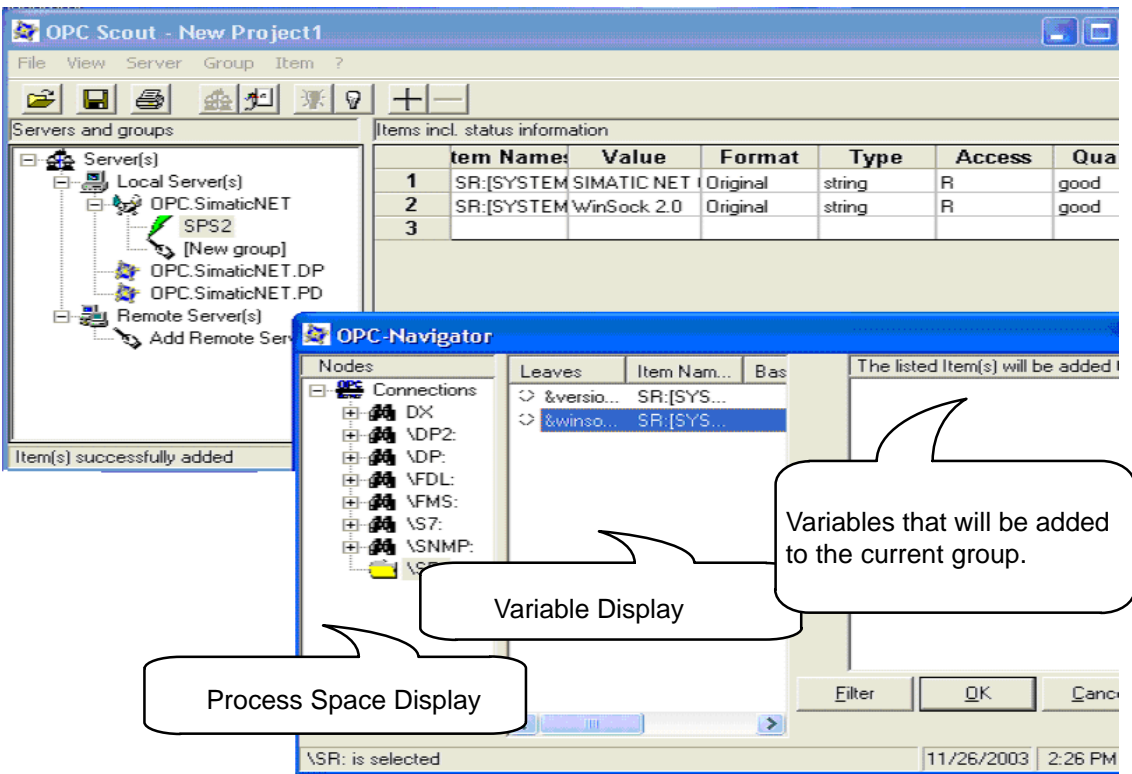



16.6 Create New Variables

You can create new variables using the **OPC Navigator** window.

Activity	
1.	In the left column of the OPC Navigator window, select the entry for which you want to create a new variable. All variables that have already been defined are displayed in the middle column.
2.	Double-click the entry New Definition. The Define New Variable window opens.
3.	Enter the data type and the related information in the appropriate boxes.
4.	Enter and name for the new variable (optional) in the Item Alias box.
5.	Click the OK button. The window is closed and the newly defined variable is displayed in the middle column of the OPC Navigator window.

16.7 Adding and Monitoring Variables

The first step is to add the variable you want to monitor to the current group.

Activity	
1.	In the middle column of the OPC Navigator window, select one or more variables you want to monitor.
2.	Click the button with the arrow pointing right. The selected variable is entered in the right-hand pane.
3.	Repeat steps 1 and 2 until all variables you want to add to the current group are displayed in the right-hand field of the OPC Navigator window.
4.	Click the OK button. The OPC Navigator window closes. The selected variables are displayed with their attributes in the main window of the OPC Scout.



16.8 Customizing the Display

You can decide what information is displayed for variables in the OPC Scout window.

Activity	
1.	Open the View menu and click the Options menu command. The Options window is displayed and the Columns to Display tab is visible.
2.	Select the information you want to have displayed for the variables in the OPC Scout.
3.	If you want to set the default column width for the displayed information, select the Standard Width tab.
4.	Select the information for which you want to specify the default width.
5.	Click the OK button. The Options window is closed and the selected information is displayed for the variables.



Meaning of the Columns

Name	Meaning
OPC ItemIDs	Unique name of the OPC item.
Value	Value of the variable displayed in the format set in the Format column.
Format	Representation For integers, you can select between the original format, hexadecimal, or binary. The "Original" format for integers is decimal. All values that are not integers are always displayed in the original format (for example, string, date, floating point). It is not possible to change the format of these data types.
Type	Canonical data type of the OPC item.
Access	Access rights for the OPC item. ("R"= read-only, "W"= write-only, "RW" = full access)
Quality	Qualifies the accuracy of the value. If the quality is "good", the value was acquired with certainty.
Time Stamp (UTC)	Time at which the OPC Server last detected a change in the value. The time stamp is displayed in UTC format (Universal Coordinated Time). The UTC time corresponds to Greenwich Mean Time (GMT).
Write Result	Result of the last write to this OPC item.
Group	Name of the group containing this OPC item.
Client Handle	Handle of the OPC item assigned by the client.
Server Handle	A handle assigned by the server.
Error	Error messages involving the use of the OPC item that cannot be attributed to "Quality" or "Write Result".

16.9 Display Attributes

You can display the attributes of individual OPC items.

Activity	
1.	Select the OPCItemIDs of the variables whose attributes you want to display in the variable display.
2.	Open the Item menu and select the Properties menu command. A dialog opens displaying the basic properties.
3.	Click the Query Available Properties button. A dialog opens in which all the properties are displayed.



16.10 Change Values

Using the OPC Scout you can modify the values of writable variables directly.

Activity	
1.	Select the variable whose value you want to change in the variable display in the main window of the OPC Scout. You can also select more than one variable and assign a common new value.
2.	Open the Item menu and select the Enter Values menu command. The Write Values of Items window opens.
3.	Select the format of the value for the variable in the Format Conversion box.
4.	Enter the required value in the Value box.
5.	Close the window with the OK button. The variable receives the new value. The new value is displayed in the OPC Scout window.

16.11 Menus of the OPC Scout in Detail

16.11.1 File Menu

The **File** menu contains the following commands:

The menu command	has the following function
Open Project	Opens an existing project. A file list box is displayed in which you can select the required project.
Save Project	Saves an existing project. If you are saving the project for the first time, a file list box opens in which you can specify the name of the project.
Save Project As...	Saves the current project under a new name. A file list box is displayed in which you can enter the new name.
Load Items	Adds the OPC items from the selected item file to the current group. Items that were previously in the group are removed.
Load and Add Items	Adds the OPC items from the selected item file to the current group. Items that were previously in the group are retained.
Save Items	Saves the OPC items shown in the variable display regardless of the group and server.
Print Item List	Prints the currently displayed items and all the values.



The menu command	has the following function
Print Item List to File	Writes the currently displayed items and all values to a file. A file list box is displayed in which you can enter the file name.
Print Project to File	Writes information about servers, groups, and all items of all groups to a file.
Exit	Closes OPC Scout. You will be asked whether or not you want to save the current project.

16.11.2 View Menu

The **View** menu contains the following commands:

The menu command	has the following function
Toolbar	Toggles display of the toolbar on/off.
Status bar	Toggles display of the status bar on/off.
Refresh	Refreshes the display on the screen.
Options	Opens the Options window in which you can decide which attributes of the variables are displayed in the OPC Scout window and can select the width of the columns.

16.11.3 Server Menu

The **Server** menu contains the following commands:

The menu command	has the following function
Connect	Establishes the connection from the OPC Scout to a local or remote server.
Disconnect	Terminates the connection from the OPC Scout to a server.
Properties	A dialog box opens in which you can display the standard properties of the OPC Server.



16.11.4 Group Menu

The **Group** menu contains the following commands:

The menu command	has the following function
Add Group	Adds a group. The Add Group window opens. You enter the name and properties of the group in the window.
Remove Group	Deletes the selected group.
Add Item	Adds an item to a group.
Activate	Activates the group. Value changes for active items of the this group are displayed.
Deactivate	Deactivates the group. Value changes for items are no longer displayed.
Properties	Opens a dialog box in which you can display the standard properties of the group.

16.11.5 Item Menu

The **Item** menu contains the following commands:

The menu command	has the following function
Add Item(s)	Adds an OPC item to the active group. The OPC Navigator window opens in which you can select the item.
Remove Item(s)	Deletes an OPC item from the group.
Enter Value(s)	Writes a value for an item. The Write Values of the Items window opens in which you can enter the value.
Generate Values	Creates simulated values for an item for test purposes. The Generate Values window opens in which you can specify which values will be displayed.
Properties	Opens a dialog box in which you can display the standard properties of the items.
Activate	Activates the item so that value updates are displayed.
Deactivate	Deactivates the item so that no value updates are displayed.



16.11.6 ? Menu

The ? menu contains the following commands:

The menu command	has the following function
Change Language	Changes the display language of the OPC Scout.
About OPC Server	Opens a dialog box with general information on the OPC Server and version.
About OPC Scout	Opens a dialog box with general information on the OPC Scout and version.

17 DCOM Settings with the dcomcnfg System Program

17.1 Characteristics, Functions and Activation

To allow a client to use a COM object on another computer, the properties of the COM object must be configured on the client and on the remote computer.

You configure DCOM and the required COM objects using the Windows system program dcomcnfg.

The following chapter contains information on configuring the client computer and the configuring the computer with the OPC Server. This chapter describes the situation in which exactly one client connects to an OPC server running on a different computer. If you want to use more than one OPC server from a client, please refer to the DCOM documentation.

Calling dcomcnfg

Alternatively, start the dcomcnfg program as follows:

- Type in “dcomcnfg” in the “Run” dialog.

or

- In the Windows Start menu, select “Settings -> Control Panel”. In the window that opens, select the “Administrative Tools” icon and then the “Component Services” icon (Note: Depending on your operating system, the names may be slightly different).

Depending on your operating system, you now come directly (or you must make a further selection) to the properties dialog for DCOM that can consist of up to 6 tabs.

In Windows XP, you should therefore first right-click in the open window and select the context menu command “My Computer”.

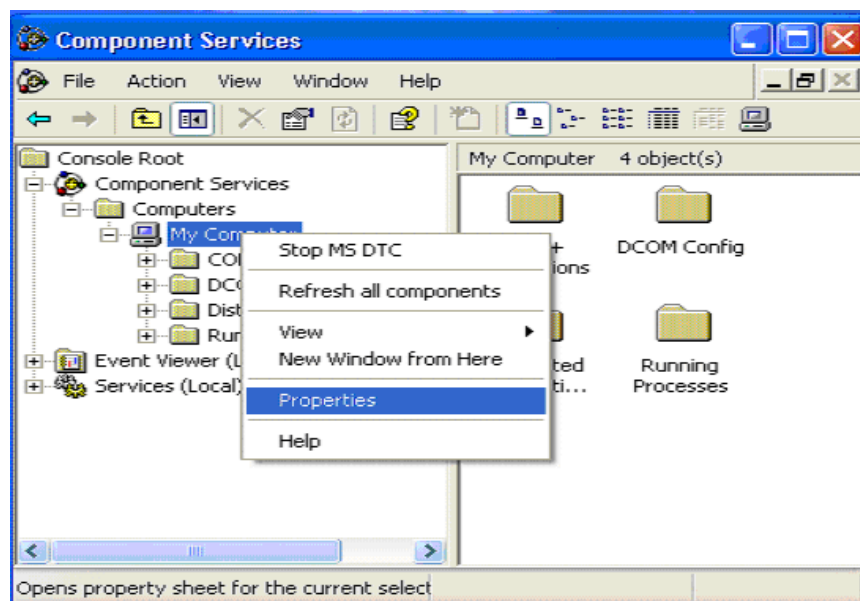

This opens the required properties dialog

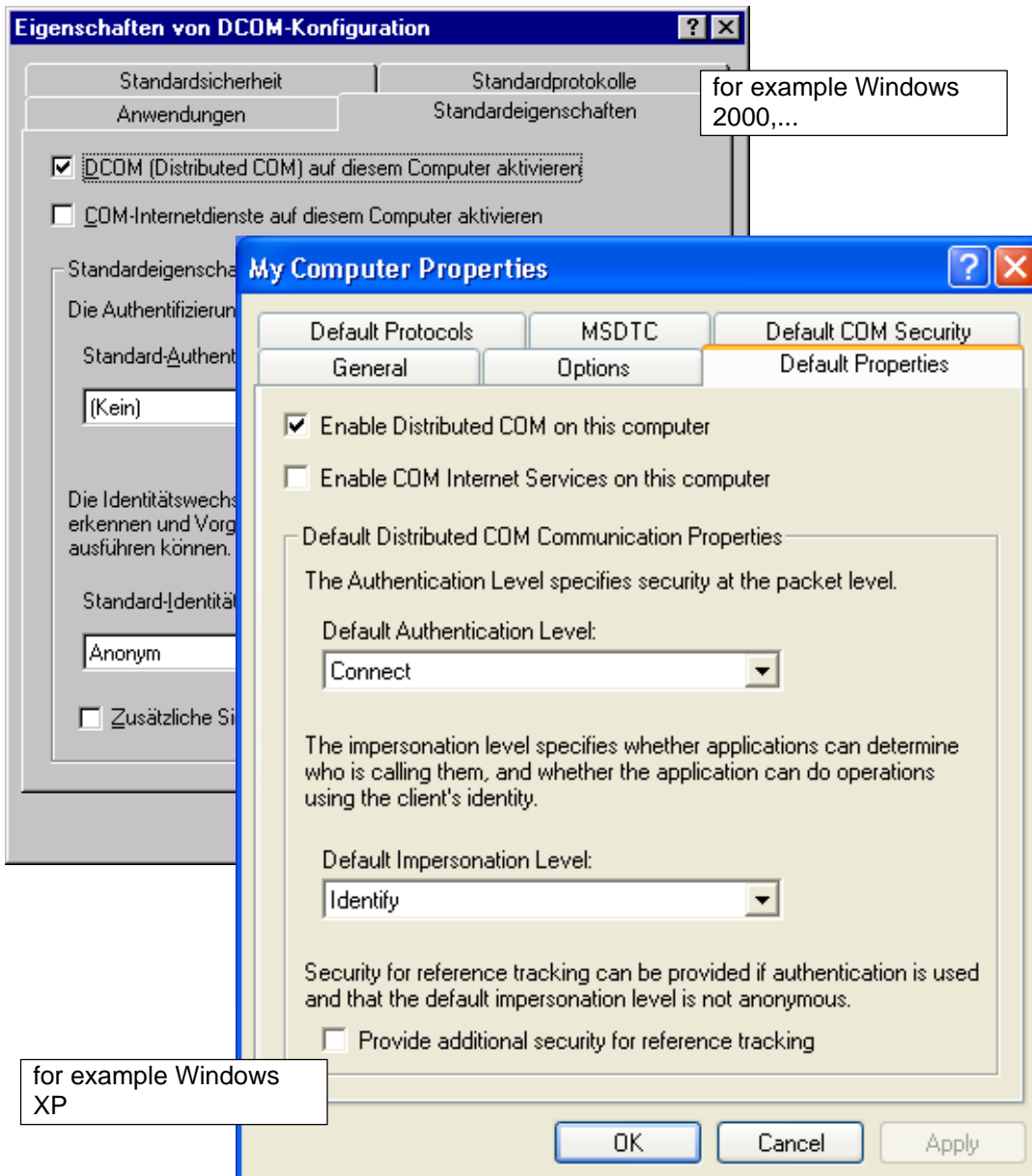

The “General”, “Options” and “MSDTC” tabs only appear in Windows XP and are not discussed further in this section. The “Default Properties”, “Default Protocols” and “Default COM Security” tabs provide the same setting options as in other Windows versions.

In Windows XP, the “Applications” tab is absent. Open the “DCOM Configuration” folder in “My Computer” to display all the COM objects available on the computer.

Open the context-sensitive menu (right-click) on “My Computer”. A dialog box with 6 tabs opens.

Note

If you lower the security settings, the system must be restarted to activate the changes.

Notice

The settings listed in this description guarantee simple installation and startup of the DCOM protocol. Some of the security settings of the operating system are reduced. To meet stricter security requirements, you must increase the settings according to the DCOM guidelines.

17.2 "Default Properties" Tab

Description of the Settings

In the "Default Properties" tab, you specify basic properties of DCOM.

Operation on a Domain Server or in a Workgroup

The settings made in the DCOM configuration depending on whether the computer with the OPC Server is logged on in a domain or is operated within a workgroup.

If it operates within a domain, the server computer can check the configured rights of other accounts over the network (authentication). This is only possible when the accounts of the user are registered with this domain.

Operation in domain should be considered the ideal solution.

Settings

When operating in a domain, the default authentication level can be set to “Connect” and the Default Impersonation Level to “Identify” for security reasons. In this case the relevant accounts must be specified in the “Default Security” (see Section 17.3).

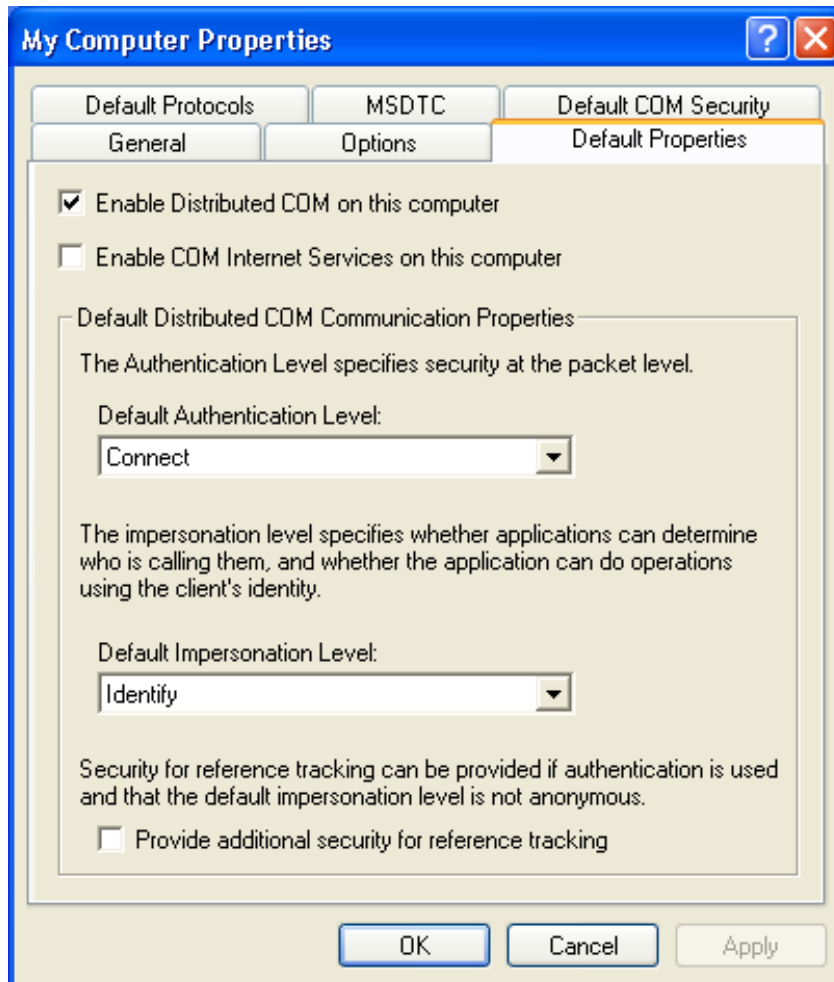

For DCOM operation with the OPC server within a workgroup (no domain server available for authentication) make the settings as shown here.

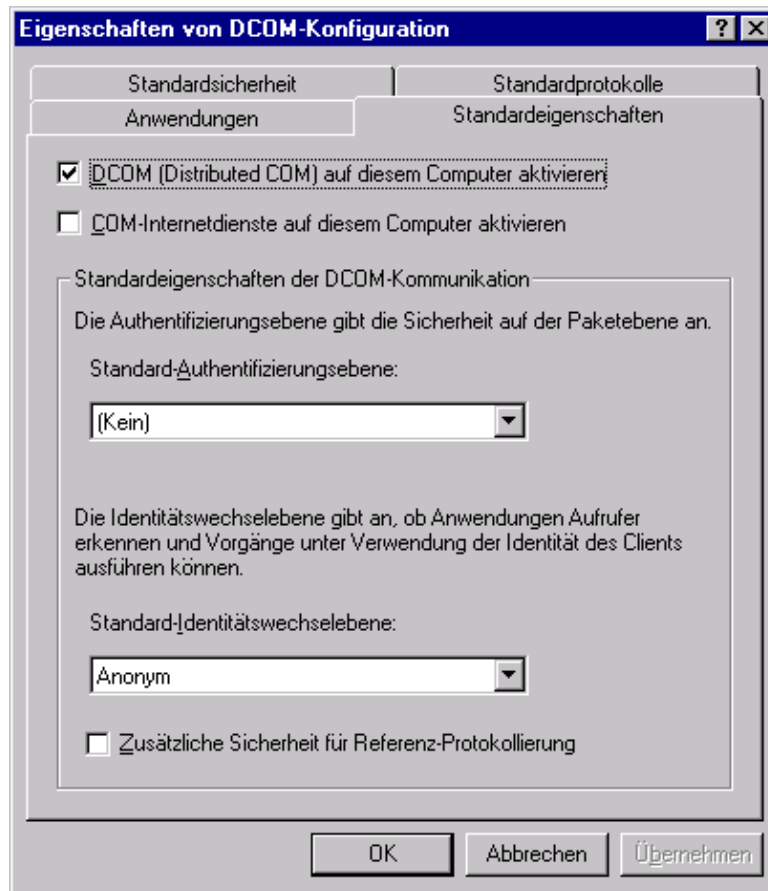

17.3 “Default Security” Tab

Description of the Settings

In the “Default Security” tab, you can specify the rights for DCOM operation. These properties are used by all COM objects that do not have their own settings (settings made after selection in the “Applications” tab).

These settings make sure that only clients with the correct permissions can use the server.

The following default permissions are relevant in conjunction with DCOM:

Table 17-1

Default Permissions	Meaning
Access permissions	The default access permissions for all COM objects specify which accounts are allowed to access the object; in other words, call the methods and which accounts are explicitly denied access.
Launch permissions	The default launch permissions for all COM objects specify which accounts have the right to create the object and which accounts are explicitly denied this permission.
Configuration permissions	The default configuration permissions specify which accounts can modify the information in the registry about COM objects; in other words can also install new objects on the computer.

These permissions can be set individually for each object and the default properties are then ignored.

Settings for Simple Commissioning

If you make the following settings for the user accounts "EVERYONE", "INTERACTIVE", "NETWORK" and "SYSTEM" both at the client and server end, you will find it simple to commission DCOM:

- Access permissions: (Allow access)
- Launch permissions: (Allow launch)
- Configuration permissions: (Full control)

When working in a domain, it is adequate to enter only the user accounts "SYSTEM" and the accounts of the authorized users in the lists for access, launch, and configuration rights on the client and server.

Notice

These settings make commissioning straightforward but allow every user in the network access to the computer. If you have security problems with these settings, the permissions must be restricted to individual user accounts.

17.4 DCOM Configuration / “Applications” Tab

Description of the Settings

In Windows XP, first open the “DCOM Configuration” folder in “My Computer” to display all the COM objects available on the computer.

Here, you select a COM object you want to configure and open the configuration dialog by clicking the “Properties” button.

The DCOM configuration of the properties for the computer with the OPC client differs from that of the computer with the OPC server.

The OPC server for SIMATIC NET is listed as “OPC.SimaticNET”.

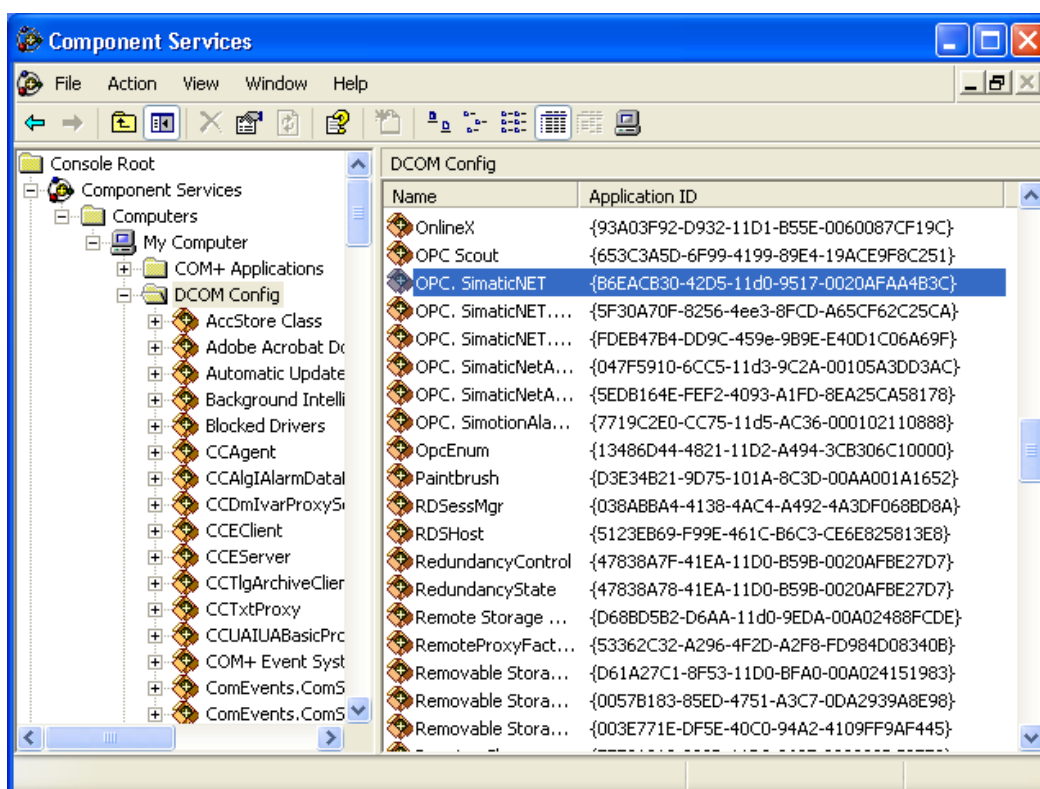

In other Windows operating systems, you will find the COM objects in the “Applications” tab.

17.5 “Default Protocols” Tab

Description of the Settings

In the “Default Protocols” tab, you specify the network protocols that are available for DCOM.

Note

The OPC server of SIMATIC NET was tested with the “Connection-oriented TCP/IP” protocol.

Since the order of the protocols in the dialog decides the priority, DCOM uses the protocol at the top of the list if it is available.

Notice

To operate the PROFINet OPC server, the “Connection-oriented TCP/IP” protocol must be at the top of the list. This setting is also necessary when the OPC Server runs on the same computer as the OPC client.

When communicating with a PROFINet partner (that is not normally a member of the domain), remember to use the workgroup settings!

17.6 Configuration of the Server Computer

Introduction

On the PC station in which the OPC server is operated, you must set which accounts have the right to use the server. In addition to the special permissions in conjunction with OPC, the account of the user of the OPC servers must also have user permissions.

Below you will see the tabs in which you can make the necessary settings.

Select the application and click on the "Properties" button.

17.6.1 “General” Tab: Registering the OPC Server

With the OPC server, the default setting assumes an open system and assumes that the user will adapt the settings when higher security is required.

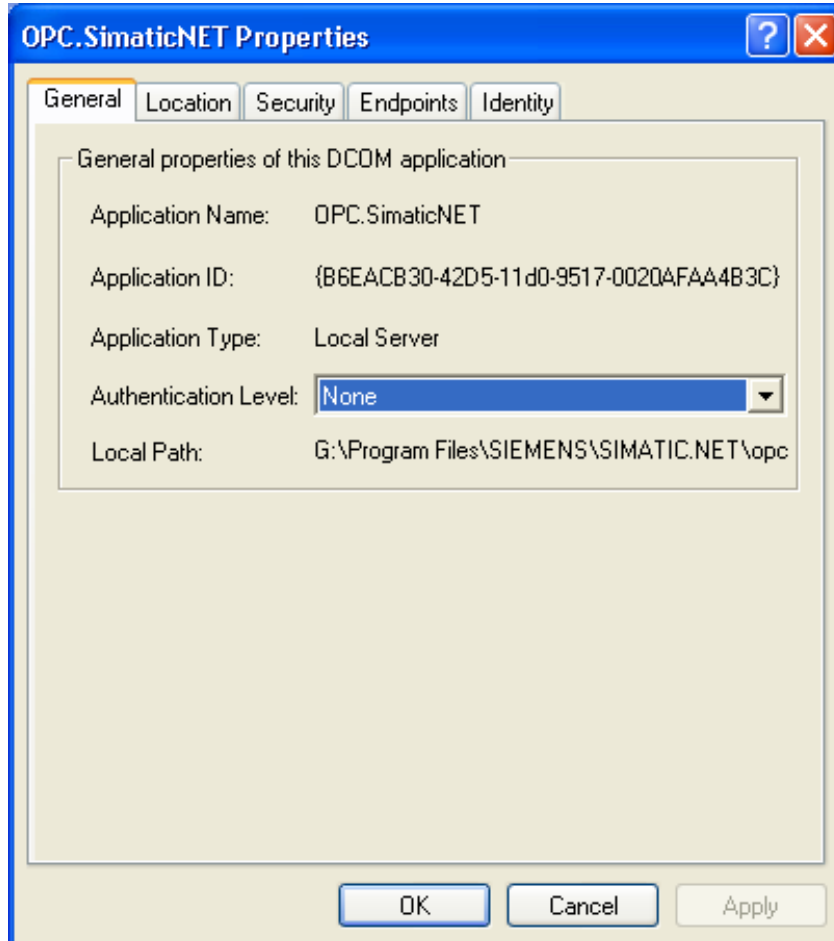

If you select the “Security” tab with this setting for the authentication level, you will see the entry “Everyone” if user-defined access right (see below in Section 17.6.4).

17.6.2 “Location” Tab

Description of the Settings

The “Location” tab is used to specify the computer on which the server is started. Since the configuration of the computer with the OPC server is described in this section, you must select the “Run application on this computer” setting.

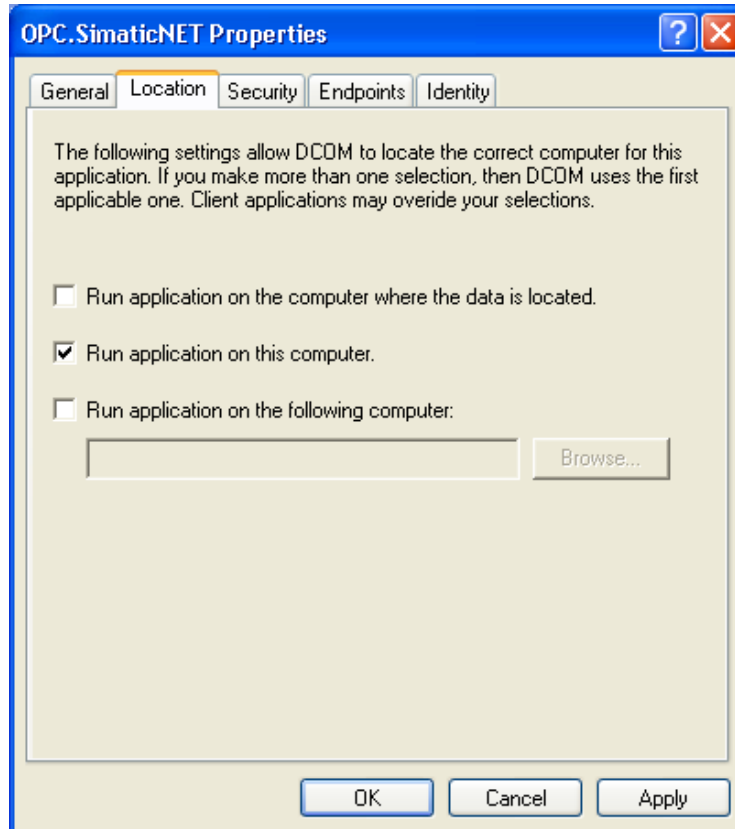

17.6.3 “Identity” Tab

Description of the Settings

The settings made in the “Identity” tab specify the account to be accessed to check the permissions of the user of the object. Here, various settings are possible:

- “Interactive User”
- “The Launching User”
- “This User”

Table 17-2

Setting	Meaning
“Interactive User”	<p>The account of the currently logged on user is used.</p> <p>If, however, no user uses the computer, there is no interactive user and the COM object cannot be created. If you operate without a logged on user, use the “This User” setting. “Interactive user” is the default setting for the OPC Server for SIMATIC NET.</p>
“The Launching User”	<p>The account of the user that launched the OPC client is used.</p> <p>This user must then also have the required permissions; in other words, must be entered in the “Security” tab. The user must also have the default permissions entered for the group of users on this computer; in other words, must belong to the group of users.</p> <p>This mode must not be used with the OPC server for SIMATIC NET, since the OPC server would otherwise be started more than once by different user accounts and this is not permitted.</p>
“This User”	<p>The account of a specified user is used. This user must have the required permissions; in other words, must be entered in the “Security” tab. The user must also have the default permissions entered for the group of users on this computer; in other words, must belong to the group of users.</p> <p>This setting must be used to operate the OPC server for SIMATIC NET (logged on users).</p> <ul style="list-style-type: none"> ● Multiterminal Mode <p>You should also use the setting described here “This user” for multiterminal mode on the PC station.</p>

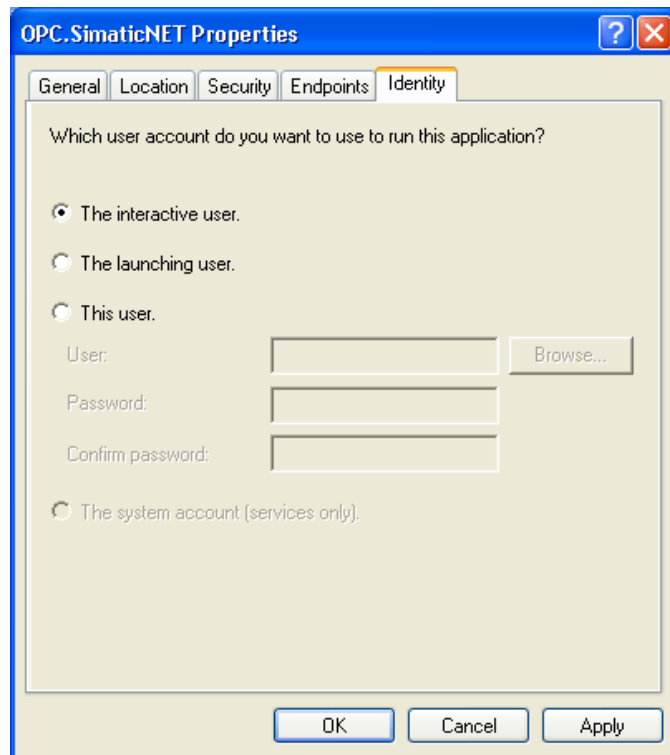

17.6.4 “Security” Tab

Introduction

You specify the access permissions for the OPC server in the “Security” tab.

For the three aspects relevant to COM objects, you can either use the default permissions or user-defined permissions for the selected COM object.

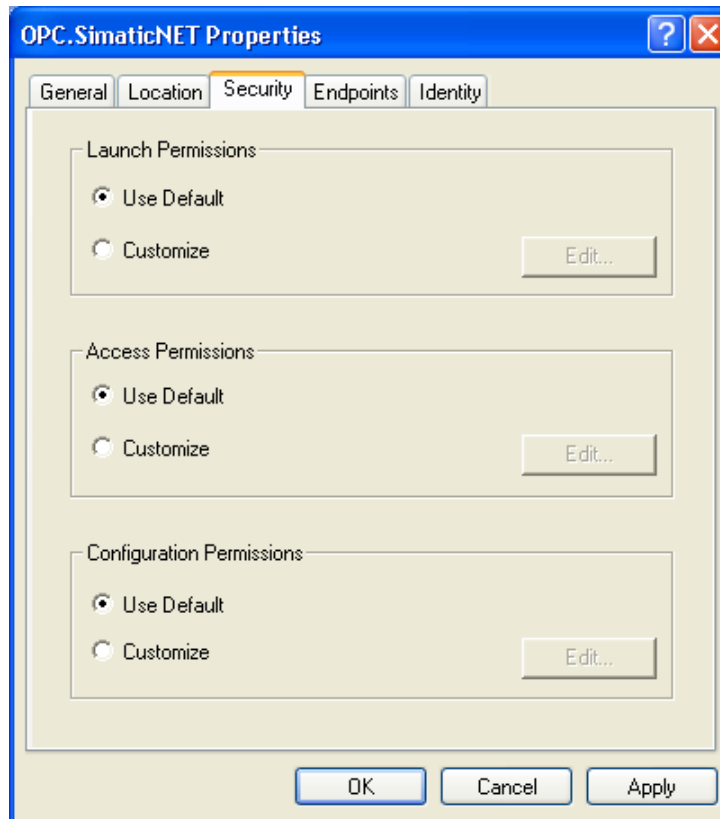

Notice

If you select the default settings in the “Security” tab, you must make sure that the necessary rights are available for the account entered in the “Identity” tab.

If you do not want a particular user to have all COM objects of the system available, you must configure user-defined permissions. To operate the OPC server, only the access permission and the launch permission need to be configured.

Specifying the Standard Permissions

The users that are allowed to use the OPC server must be entered in the default access permissions, launch permissions, and configuration permissions. Several users have been entered in the following examples of the required permissions:

Both on the server and on the client computer, the logons (and therefore the information about permissions in the logon) must exist on the other computer.

Example: User "Alpha" is logged on at the computer with the server and "Beta" is logged on at the computer with the client user. For DCOM operation a "Beta" account is required on the server computer (with the same password as on the client machine) and an "Alpha" account is required on the client computer (same password).

The use of a group with logons is advisable when using a domain. The information about permissions is then fetched from the domain server.

Note

The various OPC servers are implemented as services and therefore require access permissions for the SYSTEM account.

Multiterminal Mode

In multiterminal mode with the identity "This user" for the OPC server, you must assign standard permissions to the "This user" entry.

Specifying Access Permissions

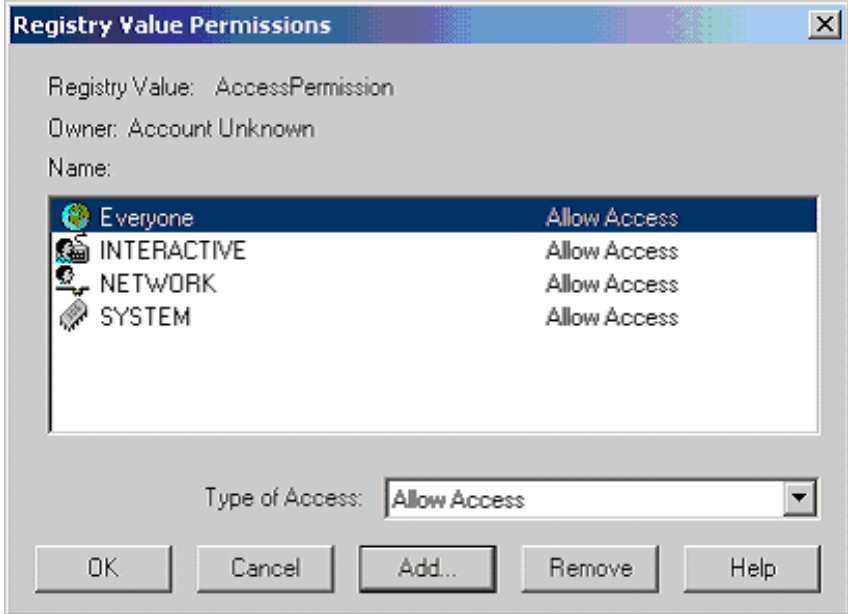
Activity	
1.	<p>After clicking the “Edit” button in the “Use custom access permissions” box, the following dialog box appears:</p> 
2.	<p>Add the account of the user under which the OPC server will start. If different, you must also add the account of the user under which the client runs.</p> <p>Access must only be permitted for the SYSTEM account to allow operation of the SIMATIC NET system services.</p>

The default setting is “Everyone”.

Specifying Launch Permissions

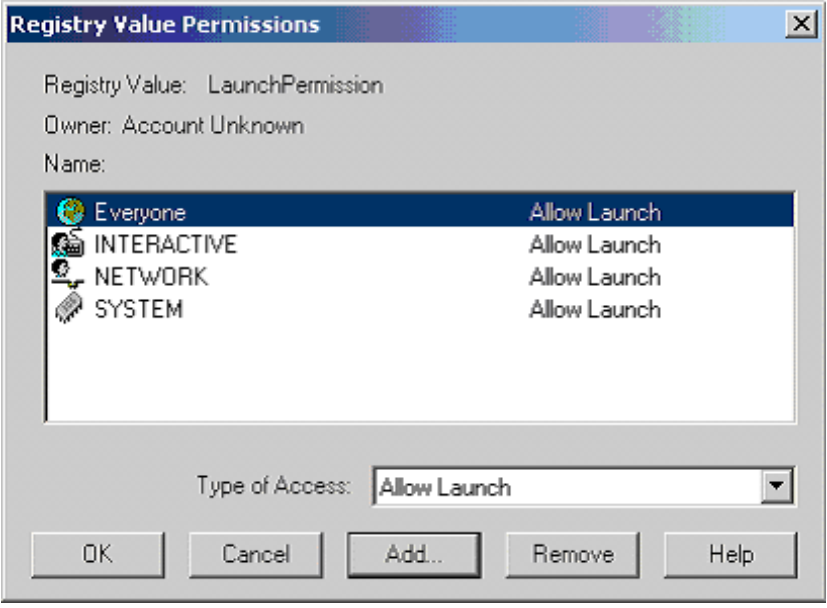
Activity	
1.	<p>After clicking the “Edit” button in the “Use custom launch permissions” box, the following dialog box appears:</p>  <p>The image shows a dialog box titled "Registry Value Permissions". It contains the following information: Registry Value: LaunchPermission, Owner: Account Unknown, Name: (empty). Below this is a list of users with their permissions: Everyone (Allow Launch), INTERACTIVE (Allow Launch), NETWORK (Allow Launch), and SYSTEM (Allow Launch). At the bottom, there is a "Type of Access" dropdown menu set to "Allow Launch" and buttons for OK, Cancel, Add..., Remove, and Help.</p>
2.	<p>Add the account of the user under which the OPC Server will be started and, if different, the account under which the client runs.</p>

The default setting is “Everyone”.

Specifying Configuration Permissions

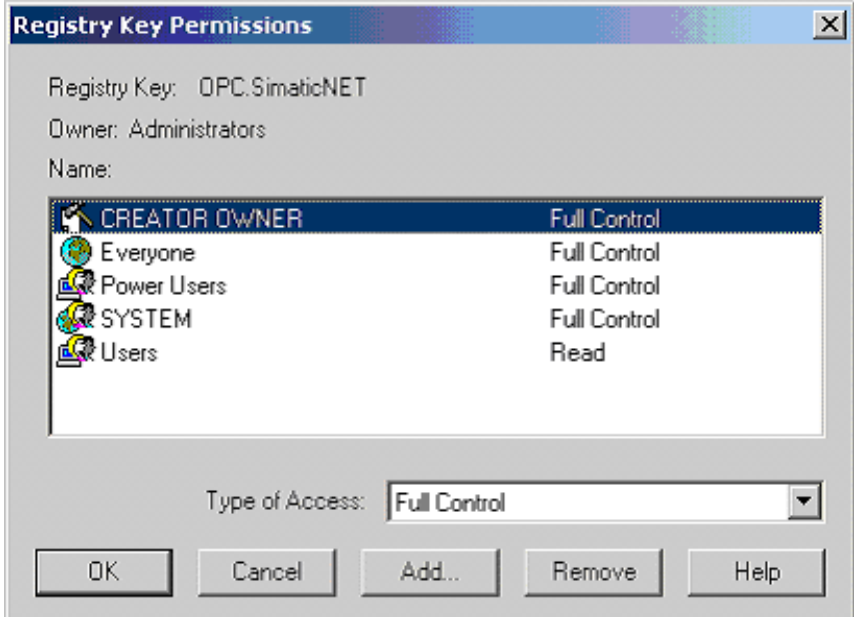
Activity	
1.	<p>After clicking the “Edit” button in the “Use custom configuration permissions” box, the following dialog box appears:</p> 
2.	<p>Add the account of the user under which the OPC Server will be started and, if different, the account under which the client runs.</p>

17.7 Configuration of the Client Computer

Overview

When operating with DCOM, this situation is that the OPC server runs on a different computer from the OPC clients (applications). This is why no process for the OPC server is visible in the Windows Task Manager of the client computer.

To allow the OPC clients to access the OPC server, the following requirements must be met for this mode:

- Registering the OPC server

The OPC server and its location must be registered on the client computer. This registration is necessary so that the COM library knows the required object making configuration possible.

You must specify the user account will be used to access the OPC server.

The procedure is described below.

- Providing "OPC proxy" libraries

The OPC Proxy libraries provided by the OPC Foundation are also required on the client computer. This library converts the COM calls into a data stream for transmission over the network.

You should also read the notes on how to install a client in the Installation Instructions.

- Registering the OPC client

When necessary access rights and security settings must be made for the OPC clients. As shown below in the example of the OPC Scout, the default setting assumes an open system and assumes that the user will adapt the settings when higher security is required.

Make the required settings analogous to the description of configuring the server computer in Section 17.6. Below, you will find instructions on registering, for example the OPC Scout as a client .

Registering the OPC server - follow the steps below:

The location of the server must be specified in the "Location" tab. For DCOM operation, only the check box "Run application on the following computer:" must be selected. Click "Browse" to locate the server computer.

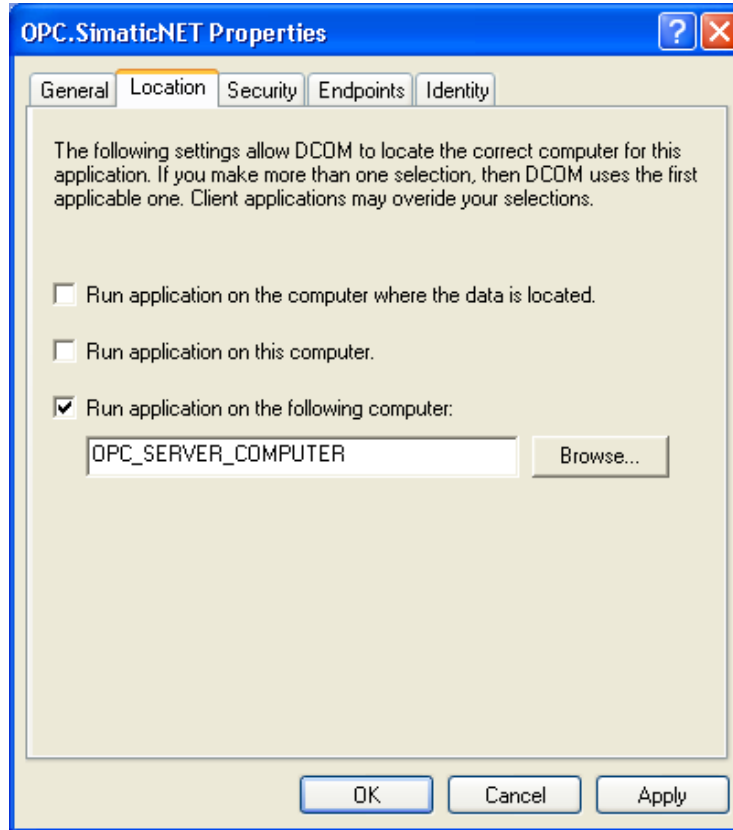

Registering the OPC Scout as Client

The OPC Scout is an OPC client that you will find in DCOM as a registered object. If you display the properties of the OPC Scout application DCOM, "None" is displayed as the authentication level. The default setting therefore assumes an open system and assumes that the user will adapt the settings when higher security is required.

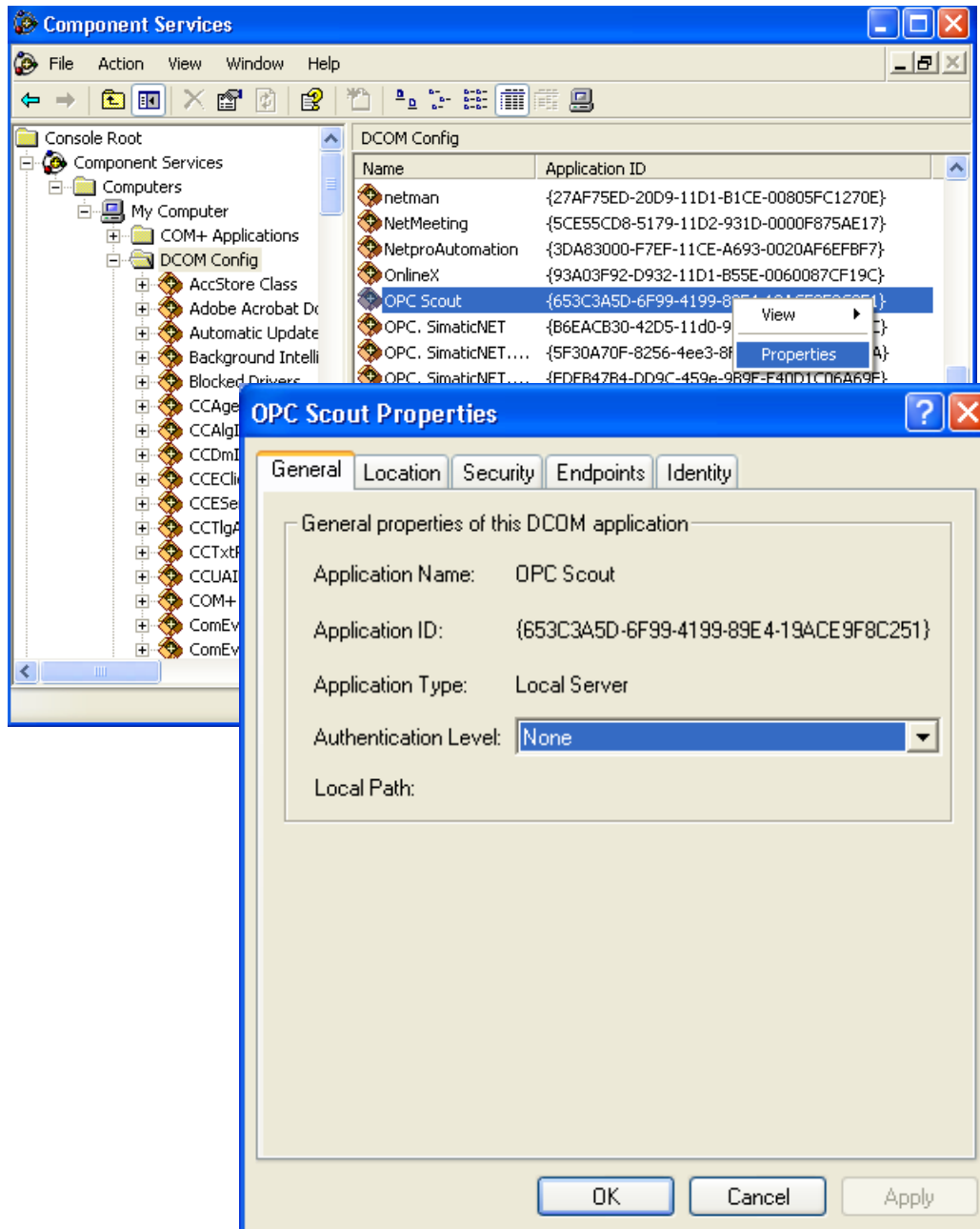

It is advisable to register other OPC clients as DCOM objects. The advantage of this is that you can configure the security settings as described here with DCOMCNFG without needing to modify system-wide settings.

Security Settings per User Program

You can also make the settings described in the earlier sections using the user program. To do this, you use the "CoInitializeSecurity ()" call from the Windows programming interface with which you can specify the DCOM security.

Notice

Remember that the security settings made in the user program have priority over the settings made in the DCOM dialog!



A Notes for Users of Older Versions

The following sections include detailed information on the differences between the new and previous PC products from SIMATIC NET

A.1 LDB and XDB Databases - Overview

Consequences of the New Central Project Engineering

As of the SIMATIC NET PC software CD 07/2001, all SIMATIC NET PC software products have central project engineering and download mechanisms. The project engineering data is now stored in XDB configuration files.

The previously used LDB databases can no longer be used.

Existing XDB databases can continue to be used after importing them into the central data management of the PC station, the Station Configuration Editor.

Requirement for compatibility of the XDB file:

The XDB configuration file must be created with a version of STEP 7 V5.1 SP2 or higher. As of this version, you will find a compatibility option in the configuration dialog for the PC station. There, you must select "S/RTM is installed".

Using the Databases and Central Data Management

The following graphics illustrate the new situation:

- Project engineering in previous product versions and the use of databases
- New, totally integrated and uniform project engineering with the Station Configuration Editor
- New, totally integrated and uniform project engineering within Advanced PC Configuration with SIMATIC NCM PC V5.1 Service Pack 2/STEP 7 Version 5.1 Service Pack 2 or higher.

The local or remote project engineering data are downloaded using SIMATIC NCM PC/STEP 7. It is also possible to transfer the project engineering data in the form of an XDB database that is also created with the Station Configuration Editor.

The OPC server and its protocol-specific adapters are optional elements and are shown with broken lines.

A.2 Project Engineering up to SIMATIC NET CD 05/2000

Description

A project engineering configuration created with the tools of the SIMATIC NET product CDs up to and including SIMATIC NET CD 05/2000 will be called the “previous project engineering” in the description below.

Previous Project Engineering with LDB databases

Each protocol of each module required its own database.

If the OPC server was used, it also required its own databases in TXT format for each protocol:

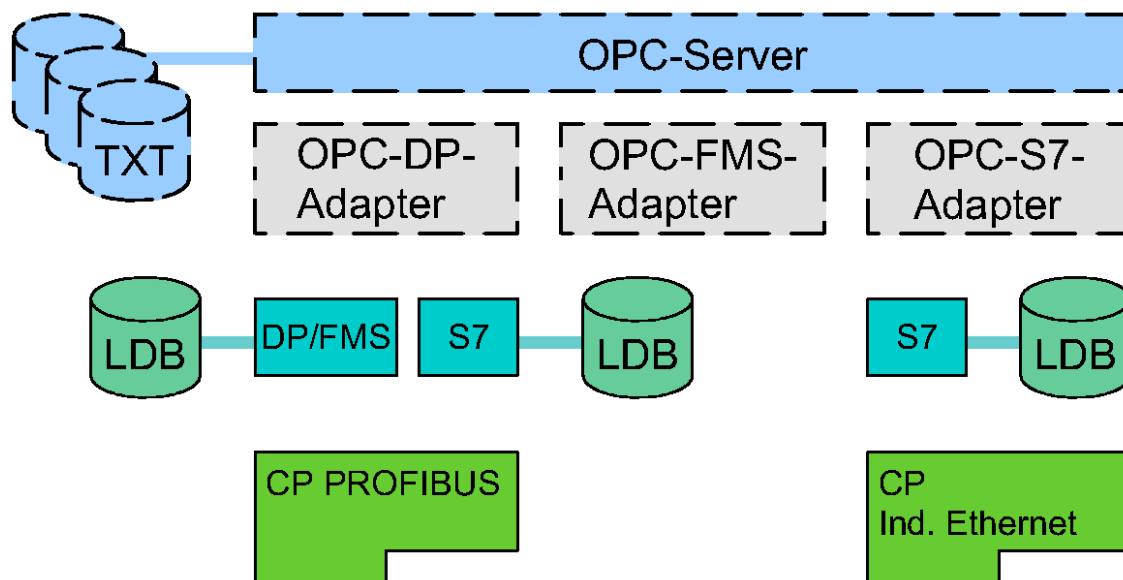

Previous Project Engineering with LDB and XDB Databases

Even when the entire communication of all modules for the S7 protocol was stored in the XDB database, separate LDB databases were required for DP and FMS.

An optional OPC server also had its own data storage:

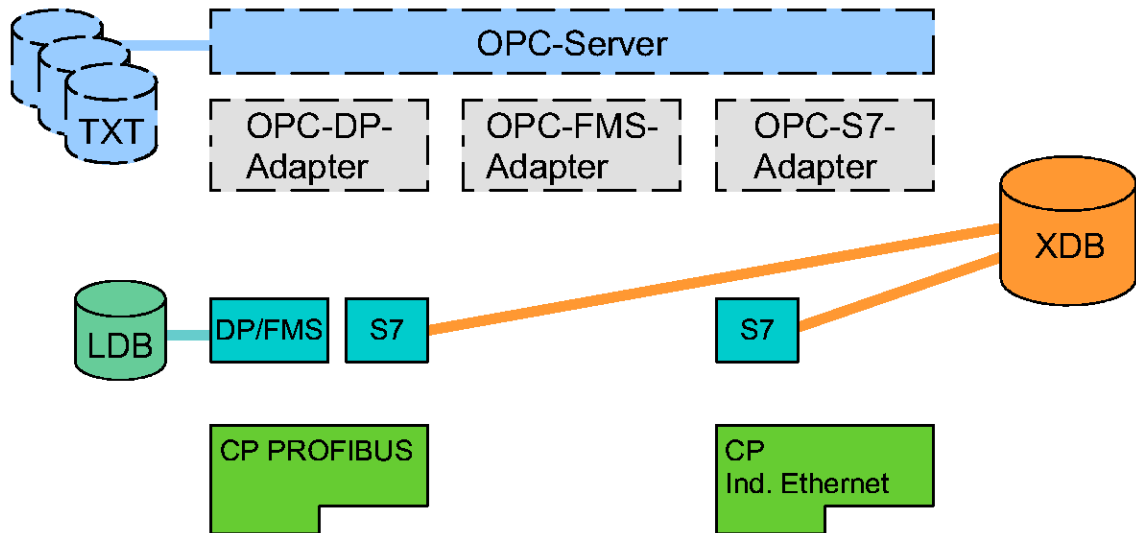

A.3 Continued Use of Previous Project Engineering

Continued Use of Databases and Project Engineering Tools

The following table shows an overview of the previous database types and the corresponding project engineering tools and indicates whether continued use is possible:

Protocol	Database Type	Project Engineering Tool	Continued Use
DP	LDB	COM PROFIBUS	Continued use not possible, the project engineering must be recreated with SIMATIC NCM PC V5.1 Service Pack 2 or STEP 7 Version 5.1 Service Pack 2 or higher.
FDL	TXT	Text Editor	Continued use not possible, the project engineering must be recreated with SIMATIC NCM PC V5.1 Service Pack 2 or STEP 7 Version 5.1 Service Pack 2 or higher.
FMS	LDB	COM PROFIBUS	Continued use not possible, the project engineering must be recreated with SIMATIC NCM PC V5.1 Service Pack 2 or STEP 7 Version 5.1 Service Pack 2 or higher.
S7	LDB	COML S7	Continued use not possible, the project engineering must be recreated with SIMATIC NCM PC V5.1 Service Pack 2 or STEP 7 Version 5.1 Service Pack 2 or higher.
S7	XDB	STEP 7	Continued use possible, the XDB database must be imported.
SEND/RECEIVE	TXT	Text Editor	Continued use not possible, the project engineering must be recreated with SIMATIC NCM PC V5.1 Service Pack 2 or STEP 7 Version 5.1 Service Pack 2 or higher.
TF	LDB	COML TF	Continued use possible, as previously with COML TF.

Note

If you want to continue using the previous project engineering tools, use the SIMATIC NET CD 05/2000.

A.4 Industrial Ethernet - Effects on Older Product Versions (SIMATIC NET CD 05/2000 and earlier)

Introduction

This section describes what changes are necessary in Industrial Ethernet systems if you are already using a SIMATIC NET CD 05/2000 product or a previous version.

PG-1413, S7-1413, TF-1413 up to version 5.2 with Service Pack 2 for Windows NT 4.0 or Windows 98

Situation:

These products are not supported by the SIMATIC NET CD 07/2001.

Simultaneous installation of these products with products of the new CD 07/2001 is not permitted and is prevented.

What to do:

Keep using the products of the SIMATIC NET 5/2000 CD if you want to use a CP 1413 in your computer or replace it with a CP 1613.

PG-1613 up to version 2.1 for Windows 2000 Pro or Windows NT 4.0

Situation:

PG operation possible as before.

What to do:

No action necessary

S7-1613 up to version 2.1 for Windows 2000 Pro or Windows NT 4.0

Situation:

S7 project engineering created with the COML S7 program cannot be used.

What to do:

A project engineering configuration created with the COML S7 program must be recreated with SIMATIC NCM PC V5.1 Service Pack 2 or higher or STEP 7 Version 5.1 Service Pack 2 or higher.

If the project engineering configuration was already created with STEP 7 (XDB), this STEP 7 project can continue to be used. You only need to download the project engineering data to the CP/PC station from STEP 7 Version 5.1 Service Pack 2 or higher.

TF-1613 up to version 2.1 for Windows 2000 Pro or Windows NT 4.0

Situation:

Application associations will continue to be configured as previously with the COML TF program.

Support of this protocol by SIMATIC NCM PC or STEP 7 with OPC is not planned.

The SEND/RECEIVE programming interface included in the product TF-1613 can continue to be used unchanged. If you use the OPC interface, it will be possible, in future, to configure SEND/RECEIVE communication with SIMATIC NCM PC or STEP 7!

What to do:

No action necessary

SOFTNET-PG up to version 3.3 for Windows 2000 Pro, Windows NT 4.0 or Windows 98

Situation:

Windows 98 is no longer supported.

PG operation under Windows 2000 Pro or Windows NT 4.0 remains possible and is unchanged.

What to do:

Under Windows 98, use the SIMATIC NET CD 05/2000.

SOFTNET-PG up to version 3.3 with Service Pack 2 for Windows 2000 Pro, Windows NT 4.0, Windows Me or Windows 98

Situation:

Windows Me and Windows 98 are no longer supported.

PG operation under Windows 2000 Pro or Windows NT 4.0 remains possible and is unchanged.

What to do:

Under Windows Me or Windows 98, use the SIMATIC NET CD 05/2000.

SOFTNET-S7 up to version 3.3 for Windows 2000 Pro, Windows NT 4.0 or Windows 98

Situation:

Windows 98 is no longer supported.

An S7 project engineering configuration created with the COML S7 program cannot be used.

What to do:

Under Windows 98, use the SIMATIC NET CD 05/2000.

A project engineering configuration created with the COML S7 program must be recreated with SIMATIC NCM PC V5.1 Service Pack 2 or higher or STEP 7 Version 5.1 Service Pack 2 or higher.

If the project engineering configuration was already created with STEP 7 (XDB), this STEP 7 project can continue to be used. You only need to download the configuration to the CP/PC station from STEP 7 Version 5.1 Service Pack 2 or higher.

A.5 PROFIBUS - Effects on Older Product Versions (SIMATIC NET CD 05/2000 and earlier)

Introduction

This section describes what changes are necessary in PROFIBUS systems if you are already using a SIMATIC NET CD 05/2000 product (or a previous version).

DP-5412, FMS-5412, PG-5412, S7-5412 up to version 5.2 with Service Pack 2 for Windows NT 4.0 or Windows 98

Situation:

These products are not supported by the SIMATIC NET CD 07/2001.

Simultaneous installation of these products with products of the new CD 07/2001 is not permitted and is prevented.

What to do:

Keep using the products of the SIMATIC NET 05/2000 CD if you want to use a CP 5412 in your computer or replace it with a CP 5613.

DP 5613 up to version 2.1 for Windows 2000 Pro or Windows NT 4.0

Situation:

A DP project engineering configuration created with the COM PROFIBUS program cannot be used.

What to do:

A DP project engineering configuration created with the COM PROFIBUS program must be recreated with SIMATIC NCM PC V5.1 Service Pack 2 or higher or STEP 7 Version 5.1 Service Pack 2 or higher.

If the project engineering configuration was already created with STEP 7, this STEP 7 project can continue to be used. You only need to download the project engineering configuration to the CP/PC station from STEP 7 Version 5.1 Service Pack 2 or higher.

FMS-5613 up to version 2.1 for Windows 2000 Pro or Windows NT 4.0

Situation:

An FMS project engineering configuration created with the COM PROFIBUS program cannot be used.

What to do:

An FMS project engineering configuration created with the COM PROFIBUS program must be recreated with SIMATIC NCM PC V5.1 Service Pack 2 or higher or STEP 7 Version 5.1 Service Pack 2 or higher.

S7-5613 up to version 2.1 for Windows 2000 Pro or Windows NT 4.0

Situation:

An S7 project engineering configuration created with the COMML S7 program cannot be used.

What to do:

A project engineering configuration created with the COMML S7 program must be recreated with SIMATIC NCM PC V5.1 Service Pack 2 or higher or STEP 7 Version 5.1 Service Pack 2 or higher.

If the project engineering configuration was already created with STEP 7 (XDB), this STEP 7 project can continue to be used. You only need to download the project engineering configuration to the CP/PC station from STEP 7 Version 5.1 Service Pack 2 or higher.

SOFTNET-DP up to version 5.3 for Windows 2000 Pro, Windows NT 4.0 or Windows 98

Situation:

Windows 98 is no longer supported.

A DP project engineering configuration created with the COM PROFIBUS program cannot be used.

It will be possible to configure SEND/RECEIVE communication on the basis of the FDL interface over OPC with SIMATIC NCM PC or STEP 7 in the future!

What to do:

Under Windows 98, use the SIMATIC NET CD 05/2000.

A DP project engineering configuration created with the COM PROFIBUS program must be recreated with SIMATIC NCM PC V5.1 Service Pack 2 or higher or STEP 7 Version 5.1 Service Pack 2 or higher.

If the project engineering configuration was already created with STEP 7, this STEP 7 project can continue to be used. You only need to download the project engineering data to the CP/PC station from STEP 7 Version 5.1 Service Pack 2 or higher.

SOFTNET-DP slave up to version 1.2 for Windows 2000 Pro, Windows NT 4.0 or Windows 98

Situation:

Windows 98 is no longer supported.

What to do:

Under Windows 98, use the SIMATIC NET CD 05/2000.

SOFTNET-S7 up to version 5.3 for Windows 2000 Pro, Windows NT 4.0 or Windows 98

Situation:

Windows 98 is no longer supported.

An S7 project engineering configuration created with the COML S7 program cannot be used.

What to do:

Under Windows 98, use the SIMATIC NET CD 05/2000.

A project engineering configuration created with the COML S7 program must be recreated with SIMATIC NCM PC V5.1 Service Pack 2 or higher or STEP 7 Version 5.1 Service Pack 2 or higher.

If the project engineering configuration was already created with STEP 7 (XDB), this STEP 7 project can continue to be used. You only need to download the project engineering data to the CP/PC station from STEP 7 Version 5.1 Service Pack 2 or higher.

□

B Description of the PROFINet Configuration File

Configuration File

When you install the PROFINet OPC Server for SIMATIC NET, a configuration file is installed. For special adaptations, it may be necessary to modify the factory settings contained in the configuration file.

Structure

The configuration file of the OPC Server is structured in the same way as an "ini" file of Windows; in other words, a text file with the extension "txt".

The individual sections are labeled with section names. Each section name is set in square brackets ([]).

Following the section name, there are assignments of the type "parameter=value".

Comments within the file are preceded by a comma.

The configuration file begins with a section for general protocol definition.

These are followed by sections for the parameter assignment of the connections to the configured communications partners. They contain the IP address and the PROFINet device name.

Storage location

The configuration file is stored in the protocol-specific binary directory. A user-specific storage location is also possible:

<installationpath>\OPC2\binPN\SCorePN.txt

Default Installation Path:

C:\Programs\Siemens\SIMATIC.NET\opc2\binPN

The Cycle Time Parameter

This parameter will be configured in the user interface as of SIMATIC NET V6.1 with STEP 7/SIMATIC NCM PC V5.2 and higher.

Parameter	Meaning
Syntax	[PROTOCOL] CycleTime=100
Purpose	The scan cycle time specifies how often the OPC server updates the values of the OPC items using a new communication job.
Default	100 ms
Relationship between Cycle Time and Update Rate	The "UpdateRate" parameter that can be set in the user program specifies the shortest possible interval for checking the values of the OPC items of an active OPC group. When this interval elapses, the server checks whether or not the values of the active OPC items have changed. The update rates used by the OPC Server for SIMATIC NET are multiples of the cycle time specified here during project engineering. The maximum update rate (shortest interval) is the same as the cycle time.
Relationship between the Set Protocol-specific Cycle Times	Since the SIMATIC NET OPC Server can use variables of different protocols at the same time, the maximum update rate of the OPC server is the highest value set for the scan cycle time for the active protocols (those for which connections are configured).
Example	A scan cycle time of 100 ms is configured for PROFINet. No other protocol is being used. 100 ms is used by the OPC server as the minimum update interval. The S7 protocol is now added and the scan cycle time configured for this protocol is 500 ms. Result: The OPC Server now uses the value 500 ms as the minimum update interval for all protocols.

The AbortConnectionAfter Parameter

This parameter is specified in section [<connectionname>].

The connection name contains the IP address from the iMap project engineering (network view) and the PROFnet device name configured in iMap.

Parameter	Meaning
Syntax	[192.11.2.34 S7-300 Station (1)] AbortConnectionAfter =0
Purpose	The parameter specifies whether and after what waiting time OPC terminates an unused connection.
Default	0
Possible Values	0 – the OPC server does not terminate the connection automatically (except when it is closed down). Higher than 0 – is interpreted as milliseconds, the OPC Server terminates the connection as soon as the connection is no longer used for this period of time.
Relationship between the Set Protocol-specific Cycle Times	Since the SIMATIC NET OPC Server can use variables of different protocols at the same time, the maximum update rate of the OPC server is the highest value set for the scan cycle time for the active protocols (those for which connections are configured).
Example	A scan cycle time of 100 ms is configured for PROFnet. No other protocol is being used. 100 ms is used by the OPC server as the minimum update interval. The S7 protocol is now added and the scan cycle time configured for this protocol is 500 ms. Result: The OPC Server now uses the value 500 ms as the minimum update interval for all protocols.

The InitiateTimeout Parameter

This parameter is specified in section [<connectionname>].

The connection name contains the IP address from the iMap project engineering (network view) and the PROFnet device name configured in iMap.

Parameter	Meaning
Syntax	[192.11.2.34 S7-300 Station (1)] InitiateTimeout = 15000
Purpose	If a connection establishment job cannot be processed within the InitiateTimeout time, the connection is reset and the job is started again. Particularly when establishing connections using DCOM from Microsoft, wait times of several minutes can occur if the partner does not exist or if the connection has broken down. During this time, further actions on the connection are blocked because the access is synchronous. This wait time can be reduced with this parameter.
Default	10000
Possible Values	milliseconds

The Timeout Parameter

This parameter is specified in section [<connectionname>].

The connection name contains the IP address from the iMap project engineering (network view) and the PROFINet device name configured in iMap.

Parameter	Meaning
Syntax	[192.11.2.34 S7-300 Station (1)] Timeout = 15000
Purpose	The "Timeout" parameter is an error monitoring time. If a pending job cannot be processed within this monitoring time, the job is acknowledged with an error.
Default	15000
Possible Values	milliseconds

The QualityOfStateValue Parameter

This parameter is specified in section [<connectionname>].

The connection name contains the IP address from the iMap project engineering (network view) and the PROFINet device name configured in iMap.

Parameter	Meaning
Syntax	[192.11.2.34 S7-300 Station (1)] QualityOfStateValue = 100
Purpose	The required QualityofServiceValue is used to restrict the frequency of transmission of data on a partner device. It describes the required update quality of the data. Process value on the partner device are updated at this sampling rate.
Default	100 (the cycle time of the PROFINet OPC Server)
Possible Values	milliseconds

C References and Literature

- /1/** SIMATIC NET, manual
Industrial Communication with PG/PC
Part of
- the manual package Industrial Communication with PG/PC
- the SIMATIC NET CD
Siemens AG
- /2/** SIMATIC NET, instructions
Commissioning PC Stations
Part of
- the manual package for NCM S7 for Industrial Ethernet
- the online documentation in STEP 7
Siemens AG
- /3/** SIMATIC NET IT-CP, instructions
Part of
- the manual package NCM S7 for Industrial Ethernet
- the online documentation in STEP 7 / option NCM S7 for Industrial Ethernet
Siemens AG
- /4/** SIMATIC Configuring Hardware and Connections with STEP 7
Part of the STEP 7 documentation package STEP 7 Basic Knowledge
Part of the online documentation of STEP 7
Siemens AG
- /5/** SIMATIC - Programming with STEP 7
Part of the STEP 7 documentation package STEP 7 Basic Knowledge
Part of the online documentation of STEP 7
Siemens AG
- /6/** SIMATIC STEP 7 reference manuals with manuals for
- LAD / CSF / STL
- System software for S7-300/400 System and Standard Functions
Part of the online documentation in STEP 7
Siemens AG
- /7/** For installing and operating an Industrial Ethernet network
SIMATIC NET manual Industrial Twisted Pair Networks
Siemens AG

- /8/** Ethernet, IEEE 802.3
(ISO 8802-3)
- /9/** For installing and operating an Industrial Ethernet network
SIMATIC NET manual for Triaxial Networks for Industrial Ethernet
- /10/** Lokale Netze -
Kommunikationsplattform der 90er Jahre
Andreas Zenk
Addison-Wesley
ISBN 3-89319-567-X
- /11/** TCP/IP
Internet-Protokolle im professionellen Einsatz
Mathias Hein
International Thomson Publishing
ISBN 3-8266-400-4
ITP Online-Center: <http://www.ora.de>
- /12/** RFC1006 (Request For Comment)
- /13/** RFC793 (TCP)
- /14/** RFC791 (IP)
- /15/** On the topic of programming:
Automation with STEP 7 in STL and SCL
User Manual, Programming Manual
Berger, H. / Publicis-MCD-Verlag, 2001
- /16/** On project engineering of PROFINet components and systems:

Basic help in the SIMATIC iMap engineering tool
Siemens AG
- /17/** On project engineering of PROFINet components and systems:

Component based Automation - Configuring Plants with SIMATIC iMap
Manual
Siemens AG

/18/ On using PROFINET IO and PROFINET CBA :

PROFINET System Description
System Manual
Siemens AG

/19/ On configuring and programming PROFINET IO:

From PROFIBUS DP to PROFINET IO
Programming Manual
Siemens AG

/20/ On programming PROFINET IO:

IO Base User Programming Interface
Programming Manual
Siemens AG

Order numbers

The order numbers for the SIEMENS documentation listed above can be found in the catalogs "SIMATIC NET Industrial Communication, Catalog IK PI" and "SIMATIC Programmable Logic Controllers SIMATIC S7 / M7 / C7, Catalog ST70".

You can order these catalogs and obtain further information from your local SIEMENS office or national head office.



Some of the documents listed here are also on the Manual Collection CD supplied with every CP and with the SIMATIC NET CD.

D Glossary

Access point

The access point is a symbolic name with which the user program can access the assigned communication interface / module.

Advanced PC Configuration (APC)

As of the SIMATIC NET PC/Windows CD 07/2001, a new standard for PC commissioning is available - Advanced PC Configuration. Automatic software installation, Plug and Play for all supported modules, and user-guided commissioning are also part of Advanced PC Configuration, just as greatly simplified OPC configuration and the new SIMATIC NCM PC project engineering tool.

SIMATIC NCM PC

SIMATIC NCM PC allows project engineering of SIMATIC NET PC components that is compatible with STEP 7 and serves as a substitute for the previous PC project engineering tools COML S7 and COM PROFIBUS PC Edition. A common database with STEP 7 ensures integrated project engineering including all protocols.

Station Configuration Editor

The Station Configuration Editor is the user interface of the Station Manager; this allows you access to the component management of the PC station.

Here, the components are the modules and the applications involved in communications.

The Station Configuration Editor can also be used for diagnostic purposes.

Station Manager

With the Station Manager, you can configure a PC in much the same way as an S7 station and download the configuration data over the network. The Station Manager is the basic component for project engineering and runtime of OPC applications.

PC Station

In this context, a PC station means a PC with communications modules and applications. The role of this PC might be, for example, to communicate with SIMATIC S7 devices and perform process control tasks. The term “runtime station” is also used to describe such PCs equipped with runtime software. The PC station is configured for communication with SIMATIC S7 devices in SIMATIC NCM PC / STEP 7. The required runtime software is available on the PC station after installing APC (Advanced PC Configuration).

STEP 7 Project

A STEP 7 Project is created with SIMATIC NCM PC or with STEP 7/NCM. It contains the project and project engineering data that can be downloaded to S7 stations and PC stations.

A

- Access points, 201
 - configuring, 50
- Advanced PC Configuration, 13
 - SIMATIC NCM PC, 18
 - supported modules, 14

C

- Characteristics, 13
- Compatibility, SIMATIC NCM PC and STEP 7, 149
- Configuration
 - DP master system, 157
 - PROFINET IO system, 159
- Configuration Console, 18, 182
- Configured mode, 19
 - commissioning, 22
 - getting started, 25
- Configuring connections, how to, 161
- Configuring connections; target station
 - proxy object, 162
 - S7 station; making a copy, 162
 - unspecified, 162
- Connection type
 - FDL, 57
 - ISO transport, 60
 - ISO-on-TCP, 60
 - S7, 59
- CP 1613, 198, 207

D

- Databases, 250
 - LDB, 14, 248
 - XDB, 249
- DCOM, 224
- DCOM settings, 18
- Diagnostics, with "Configuration Console", 205
- Download, 16, 163
- Downloading project engineering data, online mode - networked, 163
- DP master system, 157

E

- Engineering station, 13

F

- Features, 13

I

- Index, 17
- Industrial Ethernet, using older product
 - versions, 251
- Industrial Ethernet communication with OPC
 - Commissioning Wizard, 137
 - hardware installation, 67
 - OPC Scout, 76
 - software installation, 67
- Information service, 18, 192
- Initial configuration, 26, 140
 - with XDB file, 22, 27
 - without XDB file, 23, 29
- Installation and Commissioning, guide to , 19
- Installing hardware (PC modules), 25
- Installing SIMATIC NET PC software, 25
- Items, 44

L

- Loading configuration data, online mode -
 - local, 165
- Loading project engineering data, XDB import, 142

M

- Master, 157
- Mode of a module, 196
- Module, accessibility, 144

N

- NCM PC and STEP 7, 149
- NetPro, 146

O

- Offline mode, 143, 166
- Online mode, 143, 164
- OPC Navigator, 215
- OPC Scout, 18, 46, 212

OPC Server, 249
 connection properties, 57
 properties, 55
OPC server, 15
 errors when connecting with, 47
 project engineering, 53

P

Partial load, 145
PC station, creating, 151
PC Station Wizard, 18, 169
 New configuration, 170
 new engineering project, 32
 settings, 170
PC stations, in SIMATIC, 15
PG operation, 19
 commissioning, 21
 configuration, 39
 getting started, 38
 HMI stations, 41
Process variables, 48
PROFIBUS, using older product versions, 253
PROFIBUS communication with OPC
 DP master, 88
 DP slave, 89
 hardware installation, 82
 OPC Scout, 91
 software installation, 82
PROFIBUS DP slave, 203
PROFINET IO controller, 159
PROFINET IO system, 159
Project engineering, 16, 31, 248
Project engineering tools, 250

R

RFC 1006, 39, 43

S

SEND/RECEIVE interface, 57, 60
SIMATIC NCM PC Config, 146
SIMATIC NCM PC Manager, 146
SIMATIC NCM PC project engineering tool,
 146
SIMATIC NET, 13
SIMOTION, 49
Slave, 157
SNMP, 62
SOFTNET Industrial Ethernet modules, points
 to note, 52
Station Configuration Editor, 18, 139
STEP 7, 13, 147, 151, 247
Symbol File Configurator, 18, 171
Symbol file for OPC, 190
Symbols, 49, 174

T

Tools, 18
 Help, 148
 SIMATIC NCM PC, 146
Traces, 192

U

Users of previous PC products, 247

V

Variables, errors when adding, 47

X

XDB file, 147
XDB import, 16