

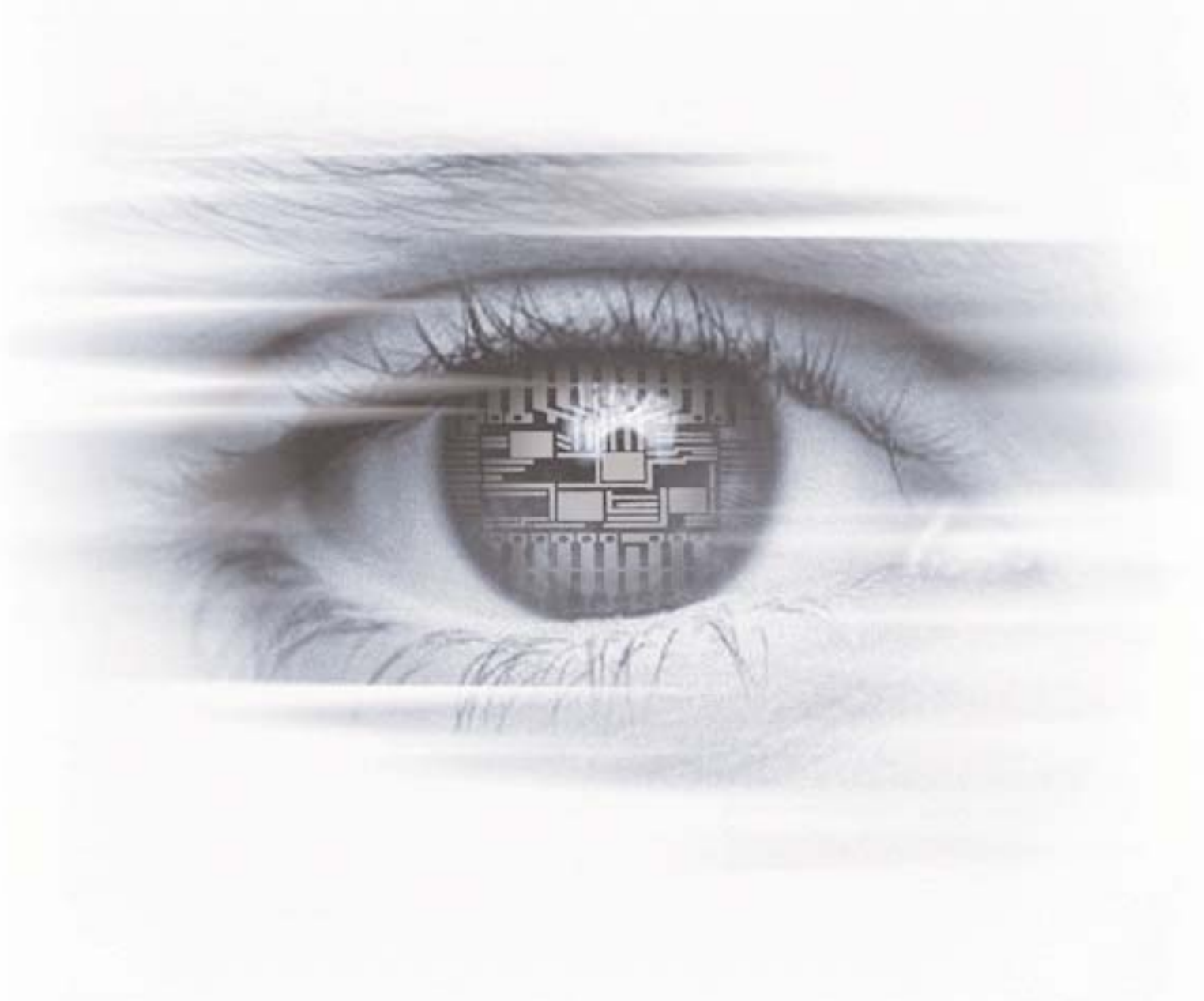

User Manual

MV-D1024E CameraLink[®] Series

CMOS Area Scan Cameras



All information provided in this manual is believed to be accurate and reliable. No responsibility is assumed by Photonfocus AG for its use. Photonfocus AG reserves the right to make changes to this information without notice.

Reproduction of this manual in whole or in part, by any means, is prohibited without prior permission having been obtained from Photonfocus AG.



Contents

1	Preface	7
1.1	About Photonfocus	7
1.2	Contact	7
1.3	Sales Offices	7
1.4	Further information	7
1.5	Legend	8
2	How to get started (CameraLink)	9
3	Product Specification	13
3.1	Introduction	13
3.2	Feature Overview	13
3.3	Technical Specification	14
3.4	Frame Grabber relevant Configuration	16
4	Functionality	19
4.1	Image Acquisition	19
4.1.1	Readout Modes	19
4.1.2	Exposure Control	21
4.1.3	Maximum Frame Rate	21
4.1.4	Constant Frame Rate (CFR)	21
4.2	Image Information	22
4.2.1	Counters and Average Value	22
4.2.2	Status Line	22
4.3	Pixel Response	23
4.3.1	Linear Response	23
4.3.2	LinLog	23
4.3.3	Skimming	27
4.3.4	Gray Level Transformation (LUT)	28
4.3.5	Test Images	30
4.4	Image Correction	33
4.4.1	Overview	33
4.4.2	Offset Correction (FPN, Hot Pixels)	33
4.4.3	Gain Correction	35
4.4.4	Corrected Image	37
4.5	Reduction of Image Size	38
4.5.1	Region of Interest (ROI)	38
4.5.2	Multiple Regions of Interest	40
4.5.3	Decimation	41
4.6	External Trigger	42
4.6.1	Trigger Source	42
4.6.2	Trigger Mode	42

4.6.3	Trigger Delay	43
4.7	Strobe Output	43
4.8	Configuration of the OEM interface	43
5	Hardware Interface	45
5.1	Connectors	45
5.1.1	CameraLink Connector	45
5.1.2	Power Supply	45
5.1.3	Trigger and Strobe Signals	46
5.1.4	Status Indicator (CameraLink cameras)	47
5.2	CameraLink Data Interface	47
5.3	Read-out Timing	49
5.3.1	Free running Mode	49
5.3.2	Constant Frame Rate Mode (CFR)	51
5.4	Trigger	53
5.4.1	Trigger Modes	53
5.4.2	Trigger Delay	55
6	The PFRremote Control Tool	57
6.1	Overview	57
6.1.1	CameraLink Model	57
6.1.2	USB 2.0 Model	57
6.2	Operating System	58
6.3	Installation Notes	58
6.3.1	Manual Driver Installation (only USB 2.0 Model)	59
6.3.2	DLL Dependencies	59
6.4	Graphical User Interface (GUI)	60
6.4.1	Port Browser	60
6.4.2	Ports, Device initialization	61
6.4.3	Main Buttons	62
6.5	Device properties	62
7	Graphical User Interface (GUI)	63
7.1	MV-D1024E-40	63
7.1.1	Exposure	64
7.1.2	Window	65
7.1.3	Trigger	67
7.1.4	Data Output	69
7.1.5	Characteristics	71
7.1.6	Correction	72
7.1.7	Info	74
7.2	MV-D1024E-80 and MV-D1024E-160	75
7.2.1	Exposure	76
7.2.2	Window	77
7.2.3	Trigger	79
7.2.4	Data Output	81
7.2.5	Characteristics	83
7.2.6	Correction	84
7.2.7	Info	86

8 Mechanical and Optical Considerations	87
8.1 Mechanical Interface	87
8.2 Optical Interface	88
8.2.1 Mounting the Lens	88
8.2.2 Cleaning the Sensor	88
8.3 Compliance	90
9 Warranty	91
9.1 Warranty Terms	91
9.2 Warranty Claim	91
10 References	93
11 Pinouts	95
11.1 Power Supply	95
11.1.1 Power Supply Connector	95
11.2 CameraLink Connector	96
12 Revision History	99

Preface

1.1 About Photonfocus

The Swiss company Photonfocus is one of the leading specialists in the development of CMOS image sensors and corresponding industrial cameras for machine vision, security & surveillance and automotive markets.

Photonfocus is dedicated to making the latest generation of CMOS technology commercially available. Active Pixel Sensor (APS) and global shutter technologies enable high speed and high dynamic range (120 dB) applications, while avoiding disadvantages, like image lag, blooming and smear.

Photonfocus has proven that the image quality of modern CMOS sensors is now appropriate for demanding applications. Photonfocus' product range is complemented by custom design solutions in the area of camera electronics and CMOS image sensors.

Photonfocus is ISO 9001 certified. All products are produced with the latest techniques in order to ensure the highest degree of quality.

1.2 Contact

Photonfocus AG, Bahnhofplatz 10, CH-8853 Lachen SZ, Switzerland

Sales	Phone: +41 55 451 00 00	Email: sales@photonfocus.com
Support	Phone: +41 55 451 01 37	Email: support@photonfocus.com

Table 1.1: Photonfocus Contact

1.3 Sales Offices

Photonfocus products are available through an extensive international distribution network and through our key account managers. Details of the distributor nearest you and contacts to our key account managers can be found at www.photonfocus.com.

1.4 Further information

For further information on the products, documentation and software updates please see our web site www.photonfocus.com or contact our distributors.



Photonfocus reserves the right to make changes to its products and documentation without notice. Photonfocus products are neither intended nor certified for use in life support systems or in other critical systems. The use of Photonfocus products in such applications is prohibited.



Photonfocus and LinLog are trademarks of Photonfocus AG. CameraLink is a registered mark of the Automated Imaging Association. Product and company names mentioned herein are trademarks or trade names of their respective companies.



Reproduction of this manual in whole or in part, by any means, is prohibited without prior permission having been obtained from Photonfocus AG.



Photonfocus can not be held responsible for any technical or typographical errors.

1.5 Legend

In this documentation the reader's attention is drawn to the following icons:



Important note.



Alerts and additional information.



Attention, critical warning.



Notification, user guide.

How to get started (CameraLink)

1. Install a suitable frame grabber in your PC.



To find a compliant frame grabber, please see the frame grabber compatibility list at www.photonfocus.com.

2. Install the frame grabber software.



Without installed frame grabber software the camera configuration tool PFRemote will not be able to communicate with the camera. Please follow the instructions of the frame grabber supplier.

3. Remove the camera from its packaging. Please make sure the following items are included with your camera:

- Power supply connector (7-pole power plug)
- Camera body cap

If any items are missing or damaged, please contact your dealership.

4. Remove the camera body cap from the camera and mount a suitable lens.



When removing the camera body cap or when changing the lens, the camera should always be held with the opening facing downwards to prevent dust or debris falling onto the CMOS sensor.

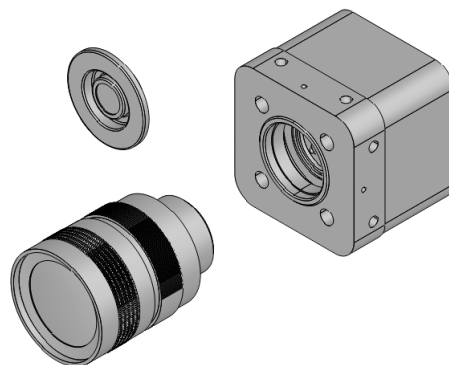



Figure 2.1: Camera with protective cap and lens.



Do not touch the sensor surface. Protect the image sensor from particles and dirt!

 The sensor has no cover glass, therefore dust on the sensor surface may resemble to clusters or extended regions of dead pixel.

 To choose a lens, see the Lens Finder in the 'Support' area at www.photonfocus.com.

5. Connect the camera to the frame grabber with a suitable CameraLink cable (see Fig. 2.2). CameraLink cables can be purchased from Photonfocus directly (www.photonfocus.com). Please note that Photonfocus provides appropriate solutions for your advanced vision applications.

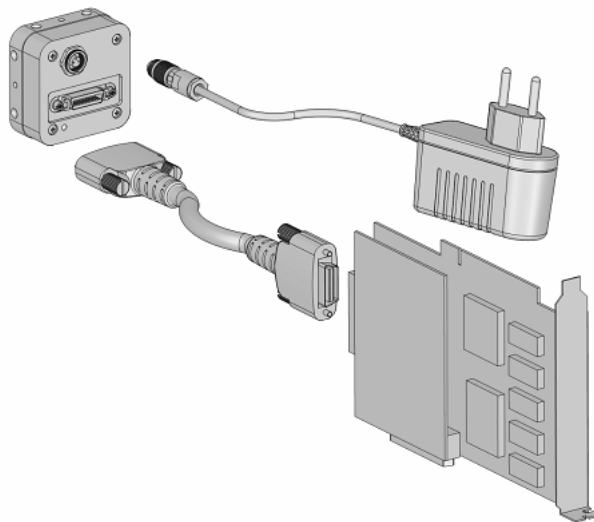

Figure 2.2: Camera with frame grabber, power supply and cable.



Do not connect or disconnect the CameraLink cable while camera power is on! For more information about CameraLink see Section 4.8.

6. Connect a suitable power supply to the provided 7-pole power plug. For the connector assembly see Fig. 11.1. The pinout of the connector is shown in Appendix 11.



Check the correct supply voltage and polarity! Do not exceed the maximum operating voltage of +12V DC ($\pm 10\%$).

7. Connect the power supply to the camera (see Fig. 2.2).



The status LED on the rear of the camera will light red for a short moment, and then flash green. For more information see Section 5.1.4.

- Download the camera software PFRemote to your computer.



You can find the latest version of PFRemote on the support page at www.photonfocus.com.

- Install the camera software PFRemote. Please follow the instructions of the PFRemote setup wizard.



Figure 2.3: Screen shot PFRemote setup wizard

- Start the camera software PFRemote and choose the communication port.

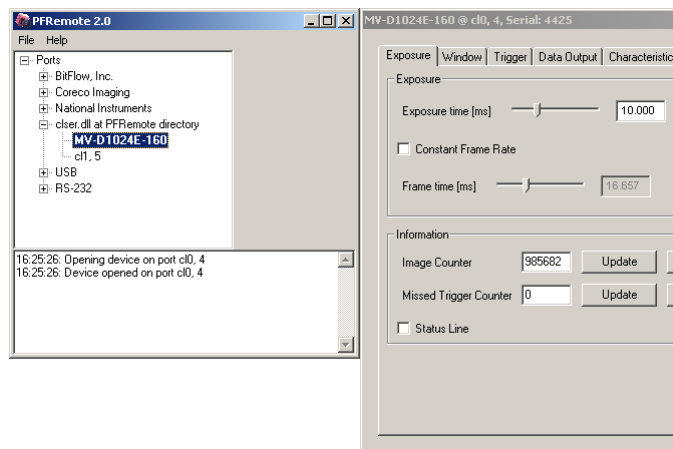

Figure 2.4: PFRemote start window

- Check the status LED on the rear of the camera.



The status LED lights green when an image is being produced, and it is red when serial communication is active. For more information see Section 5.1.4.

- You may display images using the software that is provided by the frame grabber manufacturer.

Product Specification

3.1 Introduction

The MV-D1024E CMOS camera from Photonfocus is aimed at demanding applications in industrial image processing. It provides an exceptionally high dynamic range of up to 120dB at a resolution of 1024 x 1024 pixels. The cameras are built around a monochrome CMOS image sensor, developed by Photonfocus. The principal advantages are:

- Low power consumption at high speeds
- Resistance to blooming
- Extremely high image contrast achieved by LinLog technology.
- Ideal for high speed applications: global shutter, in combination with several simultaneously selectable read out windows (Multiple ROI).
- Gray level resolution up to 12 bit
- Software is provided to set camera parameters and store them within the camera.
- The cameras have a digital CameraLink interface.
- The compact size of only or 55 x 55 x 32 mm³ (MV-D1024E-40) makes the MV-D1024E series the perfect solution for applications in which space is at a premium.

The general specification and features of the camera are listed in the following sections.

3.2 Feature Overview

	MV-D1024E CameraLink Series
Interfaces	CameraLink base configuration
Camera Control	PFRremote (Windows GUI) or programming library
Configuration Interface	CLSERIAL (9'600 baud or 57.6k baud user selectable)
Trigger Modes	Interface Trigger / I/O Trigger
Exposure Time	Defined by camera or trigger pulse width
Features	Linear Mode / LinLog Mode / Skimming
	Shading Correction (Offset and Gain)
	Gray level resolution 12 bit / 10 bit / 8 bit
	Region of Interest (ROI) / Multiple Regions of Interest (MROI)
	Look-up table (10 to 8 bit) / Decimation
	Trigger input / Strobe output with programmable delay
	Test pattern / Image information / Status line

Table 3.1: Feature overview (see Chapter 4 for more information)

3.3 Technical Specification

	MV-D1024E Series
Technology	CMOS active pixel
Scanning system	progressive scan
Optical format / diagonal	1" / 15.42 mm
Resolution	1024 x 1024 pixels
Pixel size	10.6 μm x 10.6 μm
Active optical area	10.9 mm x 10.9 mm
Random noise	< 0.5 DN RMS @ 8 bit / gain= 1
Fixed pattern noise (FPN)	< 1 DN RMS @ 8 bit / gain= 1 / offset correction on
Dark current	2 fA/pixel @ 30°C
Full well capacity	200 ke ⁻
Spectral range	400 nm ... 900 nm
Responsivity	120x10 ³ DN/(J/m ²) @ 610 nm / 8 bit / gain = 1
Optical fill factor	35%
Dynamic range	up to 120 dB (with LinLog)
Color format	monochrome
Characteristic curve	linear or LinLog, skimming
Shutter mode	global shutter
Min. Region of Interest (ROI)	1 row x 9 columns
Grayscale Resolution	12 bit / 10 bit / 8 bit
Digital Gain	x1 / x2 / x4
Exposure Time	10 μs ... 0.41 s

Table 3.2: General specification of the MV-D1024E series

	MV-D1024E-40	MV-D1024E-80	MV-D1024E-160
Exposure Time Increment	25 ns	50 ns	25 ns
Frame Rate ($T_{int} = 10 \mu\text{s}$)	37 fps	75 fps	150 fps
Pixel Clock Frequency	40 MHz	40 MHz	80 MHz
Pixel Clock Cycle	25 ns	50 ns	25 ns
Camera Taps	1	2	2
Readout mode	sequent. integration	sequent. integration	sequent. integration
	and readout	and readout or	and readout or
		simult. readout	simult. readout

Table 3.3: Model-specific parameters

	MV-D1024E-40	MV-D1024E-80	MV-D1024E-160
Operating temperature	0°C ... 60°C	0°C ... 60°C	0°C ... 60°C
Camera power supply	+12 V DC (±10%)	+12 V DC (±10%)	+12 V DC (±10%)
Trigger signal input range	+5 .. +15 V DC	+5 .. +15 V DC	+5 .. +15 V DC
Strobe signal power supply	+5 .. +15 V DC	+5 .. +15 V DC	+5 .. +15 V DC
Strobe signal sink current (average)	max. 8 mA	max. 8 mA	max. 8 mA
Max. power consumption	1.6 W	3.0 W	3.2 W
Lens mount	C- or CS-Mount	C- or CS-Mount	C- or CS-Mount
Dimensions	55 x 55 x 32 mm ³	55 x 55 x 40 mm ³	55 x 55 x 40 mm ³
Mass	200 g	210 g	210 g
Conformity	CE	CE	CE

Table 3.4: Physical characteristics and operating ranges

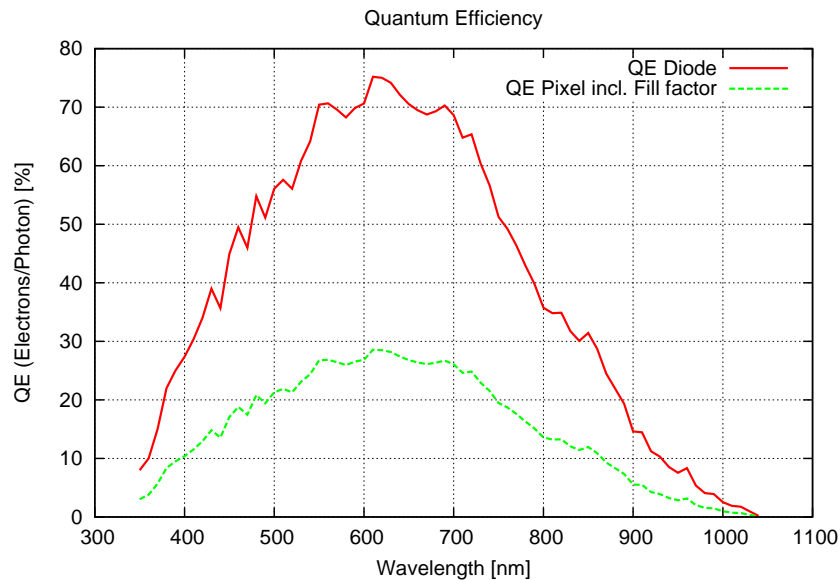

Figure 3.1: Spectral response

3.4 Frame Grabber relevant Configuration

	MV-D1024E-40	MV-D1024E-80	MV-D1024E-160
Pixel Clock per Tap	40 MHz	40 MHz	80 MHz
Number of Taps	1	2	2
Grayscale resolution	12 bit / 10 bit / 8 bit	12 bit / 10 bit / 8 bit	12 bit / 10 bit / 8 bit
CC1	EXSYNC	EXSYNC	EXSYNC
CC2	not used	not used	not used
CC3	not used	not used	not used
CC4	not used	not used	not used

Table 3.5: Summary of parameters needed for frame grabber configuration

CameraLink Port and Bit assignments are compliant to the CameraLink standard (see [CL]).

Bit	Tap 0, 8 Bit	Tap 0, 10 Bit	Tap 0, 12 Bit
0 (LSB)	A0	A0	A0
1	A1	A1	A1
2	A2	A2	A2
3	A3	A3	A3
4	A4	A4	A4
5	A5	A5	A5
6	A6	A6	A6
7 (MSB for 8 Bit Mode)	A7	A7	A7
8	-	B0	B0
9 (MSB for 10 Bit Mode)	-	B1	B1
10	-	-	B2
11 (MSB for 12 Bit Mode)	-	-	B3

Table 3.6: CameraLink port and bit assignments for MV-D1024E-40 camera

Bit	Tap 0	Tap 1	Tap 0	Tap 1	Tap 0	Tap 1
	8 Bit	8 Bit	10 Bit	10 Bit	12 Bit	12 Bit
0 (LSB)	A0	B0	A0	C0	A0	C0
1	A1	B1	A1	C1	A1	C1
2	A2	B2	A2	C2	A2	C2
3	A3	B3	A3	C3	A3	C3
4	A4	B4	A4	C4	A4	C4
5	A5	B5	A5	C5	A5	C5
6	A6	B6	A6	C6	A6	C6
7 (MSB of 8 Bit)	A7	B7	A7	C7	A7	C7
8	-	-	B0	B4	B0	B4
9 (MSB of 10 Bit)	-	-	B1	B5	B1	B5
10	-	-	-	-	B2	B6
11 (MSB of 12 Bit)	-	-	-	-	B3	B7

Table 3.7: CameraLink port and bit assignments for MV-D1024E-80 and MV-D1024E-160 cameras

Functionality

This chapter serves as an overview of the camera configuration modes and explains camera features. The goal is to describe what can be done with the camera. The setup of the camera is explained in later chapters.

4.1 Image Acquisition

4.1.1 Readout Modes

The MV-D1024E CameraLink series provides two different readout modes:

Sequential readout Frame time is the sum of exposure time and readout time. Exposure time of the next image can only start if the readout time of the current image is finished.

Simultaneous readout (interleave) The frame time is determined by the maximum of the exposure time or of the readout time, which ever of both is the longer one. Exposure time of the next image can start during the readout time of the current image.

	MV-D1024E-40	MV-D1024E-80	MV-D1024E-160
Sequential readout	available	available	available
Simultaneous readout	-	available	available

Table 4.1: Readout mode of MV-D1024E camera series

The following figure illustrates the effect on the frame rate when using either the sequential readout mode or the simultaneous readout mode (interleave exposure).

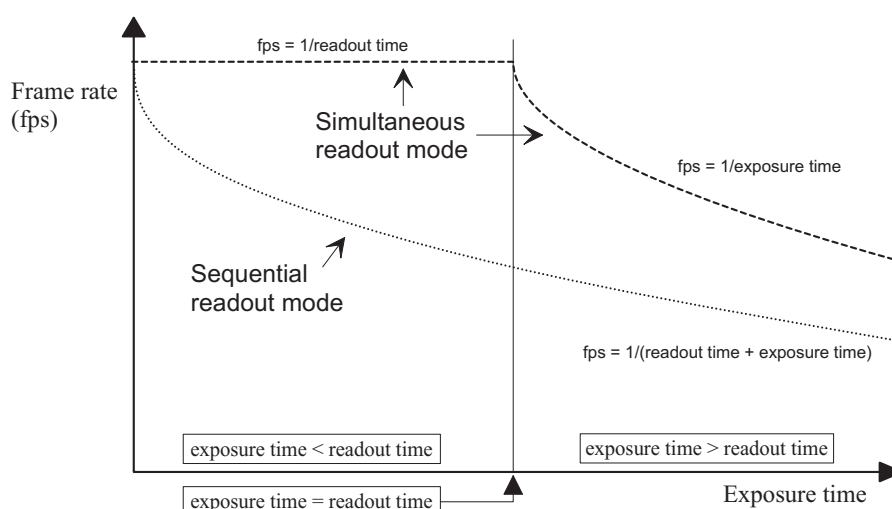



Figure 4.1: Frame rate in sequential readout mode and simultaneous readout mode

Sequential readout mode For the calculation of the frame rate only a single formula applies: frames per second equal to the invers of the sum of exposure time and readout time.

Simultaneous readout mode (exposure time < readout time) The frame rate is given by the readout time. Frames per second equal to the invers of the readout time.

Simultaneous readout mode (exposure time > readout time) The frame rate is given by the exposure time. Frames per second equal to the invers of the exposure time.

The simultaneous readout mode allows higher frame rate. However, If the exposure time strongly exceeds the readout time, then the effect on the frame rate is neglectable.

 In simultaneous readout mode image output faces minor limitations. The overall linear sensor reponse is partially restricted in the lower gray scale region.

 When changing readout mode from sequential to simultaneous readout mode or vice versa, new settings of the BlackLevelOffset and of the image correction are required.

Sequential readout

By default the camera continuously delivers images as fast as possible ("Free-running mode") in the sequential readout mode. Exposure time of the next image can only start if the readout time of the current image is finished.

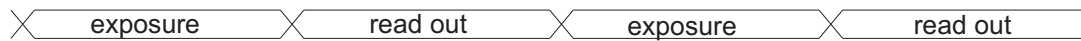

Figure 4.2: Timing in free-running sequential readout mode

When the acquisition of an image needs to be synchronised to an external event, an external trigger can be used (refer to Section 4.6 and Section 5.4). In this mode, the camera is idle until it gets a signal to capture an image.

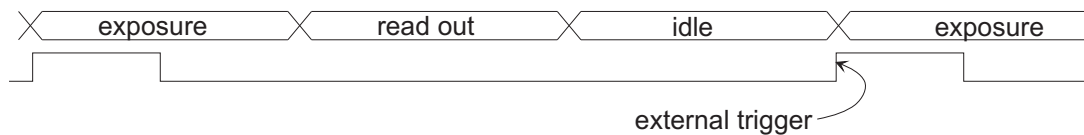

Figure 4.3: Timing in triggered sequential readout mode

Simultaneous readout (interleave exposure)

To achieve highest possible frame rates, the camera must be set to "Free-running mode" with simultaneous readout. The camera continuously delivers images as fast as possible. Exposure time of the next image can start during the readout time of the current image.

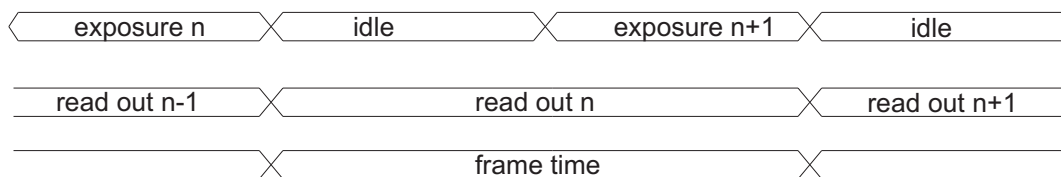

Figure 4.4: Timing in free-running simultaneous readout mode (readout time > exposure time)

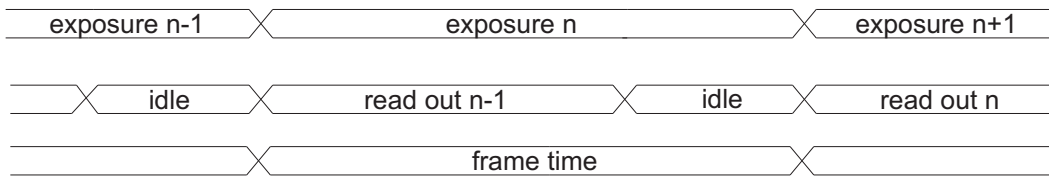

Figure 4.5: Timing in free-running simultaneous readout mode (readout time < exposure time)

When the acquisition of an image needs to be synchronised to an external event, an external trigger can be used (refer to Section 4.6 and Section 5.4). In this mode, the camera is idle until it gets a signal to capture an image.

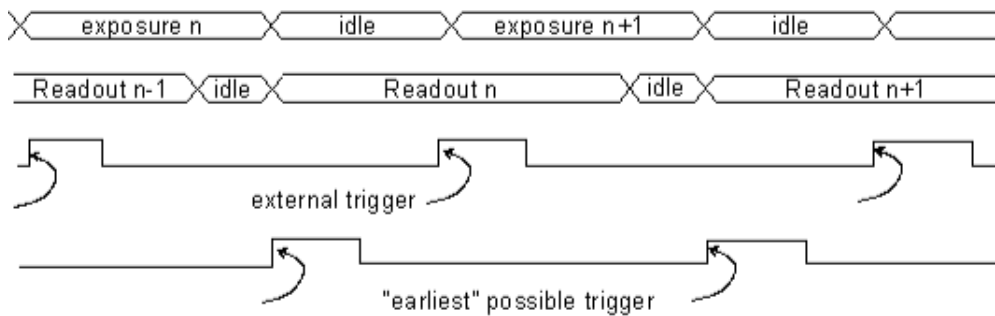

Figure 4.6: Timing in triggered simultaneous readout mode

4.1.2 Exposure Control

The exposure time defines the period during which the image sensor integrates the incoming light. Refer to Table 8.1 for the allowed exposure time range and see Section 5.4.1

4.1.3 Maximum Frame Rate

The maximum frame rate depends on the exposure time, the readout scheme and the size of the image (see Region of Interest, Section 4.5.1). In most cases, simultaneous readout is best choice for highest framerate.

 Skimming is not supported in simultaneous readout mode.

4.1.4 Constant Frame Rate (CFR)

When the CFR mode is switched on, the frame rate (number of frames per second) can be varied from almost 0 up to the maximum frame rate. Thus, fewer images can be acquired than would otherwise be possible.

When Constant Frame Rate is switched off, the camera delivers images as fast as possible, depending on the exposure time and the read-out time. See Section 5.3.2 for more information.

 Constant Frame Rate mode (CFR) is not available together with external trigger mode.

4.2 Image Information

There are camera properties available that give information about the acquired images, such as an image counter, average image value and the number of missed trigger signals. These properties can be queried by software. Alternatively, a status line within the image data can be switched on that contains all the available image information.

4.2.1 Counters and Average Value

Image counter The image counter provides a sequential number of every image that is output. After camera startup, the counter counts up from 0 (counter width 24 bit). The counter can be reset by the camera control software.

Missed trigger counter The missed trigger counter counts trigger pulses that were ignored by the camera because they occurred within the exposure or read-out time of an image. In free-running mode it counts all incoming external triggers. (Counter width 8 bit / no wrap around).

Average image value The average image value gives the average of an image in 12 bit format (0 .. 4095 DN), regardless of the currently used gray level resolution.

4.2.2 Status Line

If enabled, the status line replaces the last row of the image with image information. It contains the properties described above and additional information:

Preamble The first parameter contains a constant value of 0x55AA00FF as a preamble in order to allow the image processing system to easily recognise the beginning of the status line.

Image counter See Section 4.2.1.

Time counter The time counter starts at 0 after camera start, and counts real-time in units of 1 micro-second. The time counter can be reset by the software in the SDK (Counter width 32 bit).

Missed trigger counter See Section 4.2.1.

Average image value See Section 4.2.1.

Exposure cycles The exposure cycles parameter outputs the current exposure time in units of clock cycles (see Table 8.1).

Every parameter is coded into 4 pixels (LSB first) and uses the lower 8 bits of the pixel value, so that the total size of a parameter is 32 bit. The remaining pixels (24..1024) are set to 0.

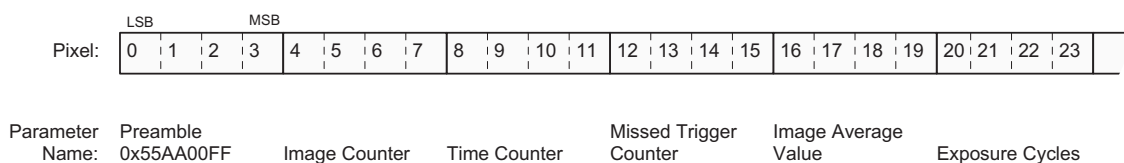

Figure 4.7: Status line parameters replace the last row of the image



The status line is also available when using an ROI. For an ROI with a width <24 pixels, the status line will be clipped.

4.3 Pixel Response

4.3.1 Linear Response

The camera offers a linear response between input light signal and output gray level. This can be modified by the use of LinLog or Skimming as described in the following sections. In addition, a linear digital gain may be applied, as follows. Please see Table 3.2 for more model-dependent information.

Gain x1, x2, x4

Gain x1, x2 and x4 are digital amplifications, which means that the digital image data are multiplied in the camera by a factor 1, 2 or 4, respectively.

Black Level Adjustment

The black level is the average image value at no light intensity. It can be adjusted by the software by changing the black level offset. Thus, the overall image gets brighter or darker. Use a histogram to control the settings of the black level.

4.3.2 LinLog

Overview

The LinLog technology from Photonfocus allows a logarithmic compression of high light intensities inside the pixel. In contrast to the classical non-integrating logarithmic pixel, the LinLog pixel is an integrating pixel with global shutter and the possibility to control the transition between linear and logarithmic mode.

In situations involving high intrascene contrast, a compression of the upper gray level region can be achieved with the LinLog technology. At low intensities each pixel shows a linear response. At high intensities the response changes to logarithmic compression (see Fig. 4.8). The transition region between linear and logarithmic response can be smoothly adjusted by software and is continuously differentiable and monotonic.

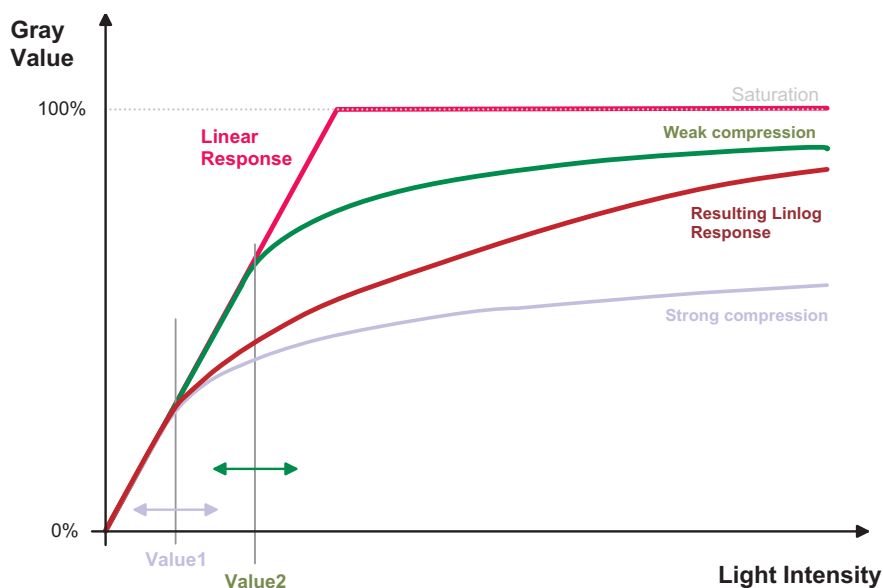

Figure 4.8: Resulting LinLog2 response curve

LinLog is controlled by up to 4 parameters (Time1, Time2, Value1 and Value2). Value1 and Value2 correspond to the LinLog voltage that is applied to the sensor. The higher the parameters Value1 and Value2 respectively, the stronger the compression for the high light intensities. Time1 and Time2 are normalised to the exposure time. They can be set to a maximum value of 1000, which corresponds to the exposure time. Examples in the following sections illustrate the LinLog feature.

LinLog1

In the simplest way the pixels are operated with a constant LinLog voltage which defines the knee point of the transition. This procedure has the drawback that the linear response curve changes directly to a logarithmic curve leading to a poor gray resolution in the logarithmic region (see Fig. 4.10).

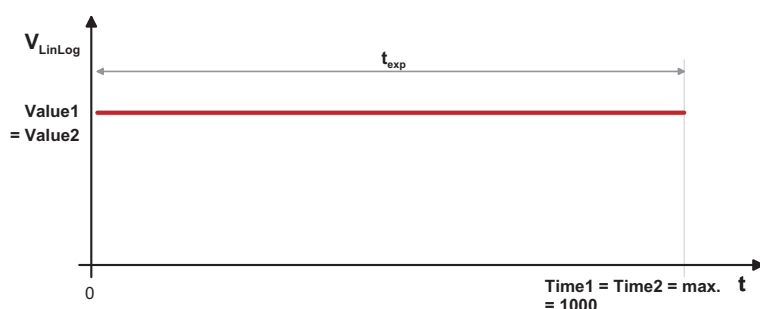

Figure 4.9: Constant LinLog voltage in the Linlog1 mode

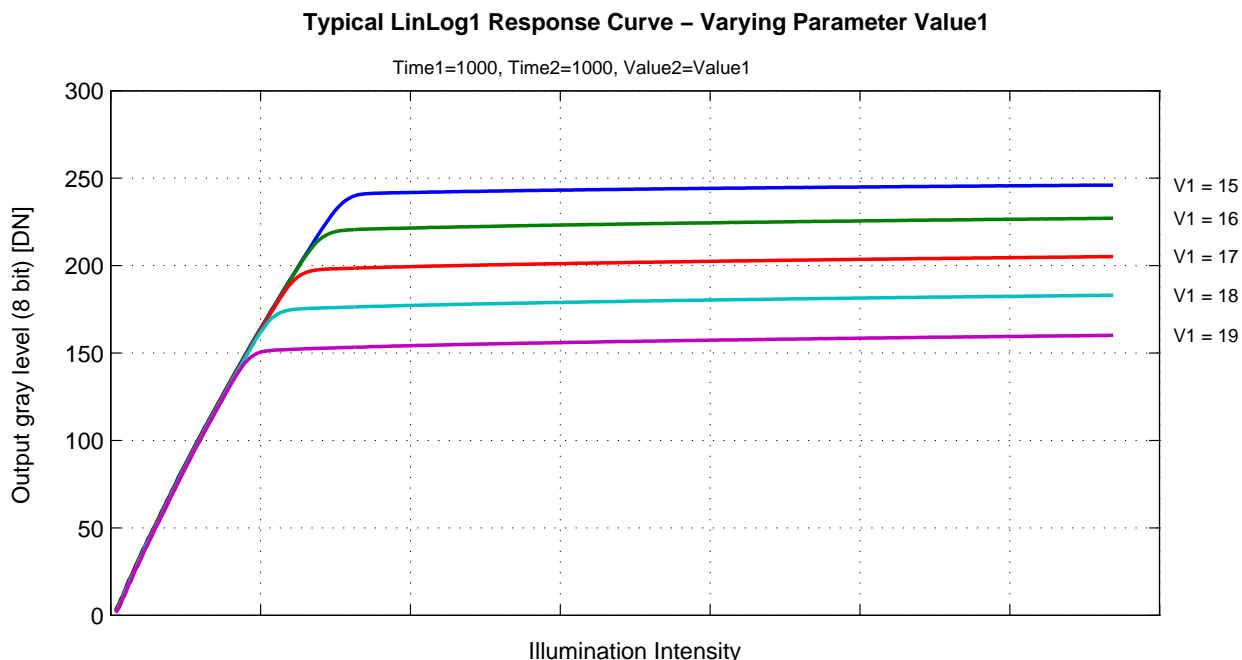

Figure 4.10: Response curve for different LinLog settings in LinLog1 mode

LinLog2

To get more gray resolution in the LinLog mode, the LinLog2 procedure was developed. In LinLog2 mode a switching between two different logarithmic compressions occurs during the exposure time (see Fig. 4.11). The exposure starts with strong compression with a high LinLog voltage (Value1). At Time1 the LinLog voltage is switched to a lower voltage resulting in a weaker compression. This procedure gives a LinLog response curve with more gray resolution. Fig. 4.12 and Fig. 4.13 show how the response curve is controlled by the three parameters Value1, Value2 and the LinLog time Time1.



Settings in LinLog2 mode, enable a fine tuning of the slope in the logarithmic region.

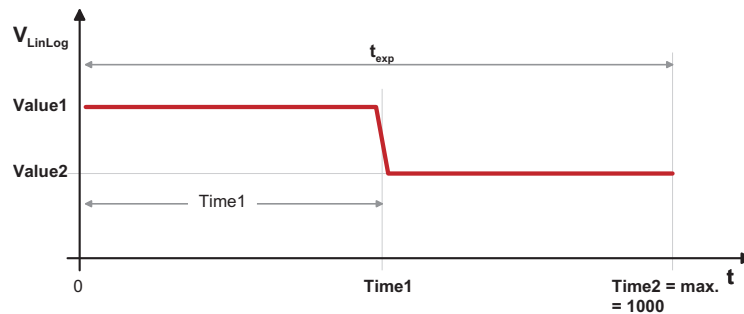

Figure 4.11: Voltage switching in the Linlog2 mode

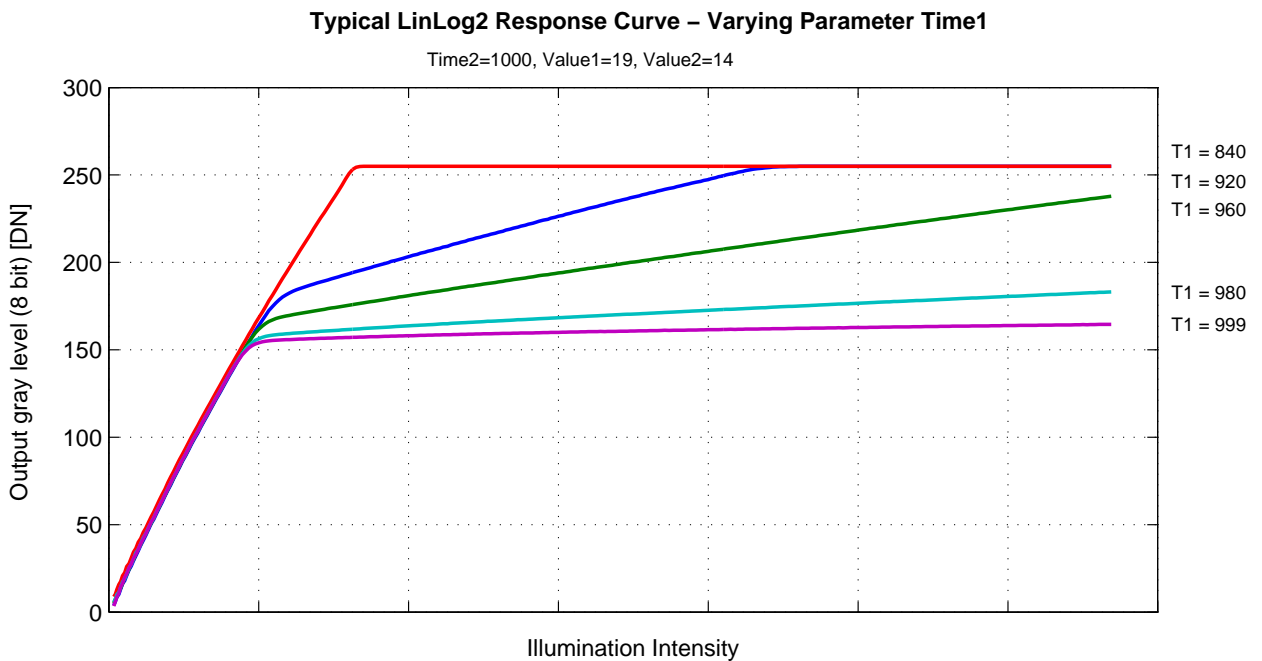

Figure 4.12: Response curve for different LinLog settings in LinLog2 mode

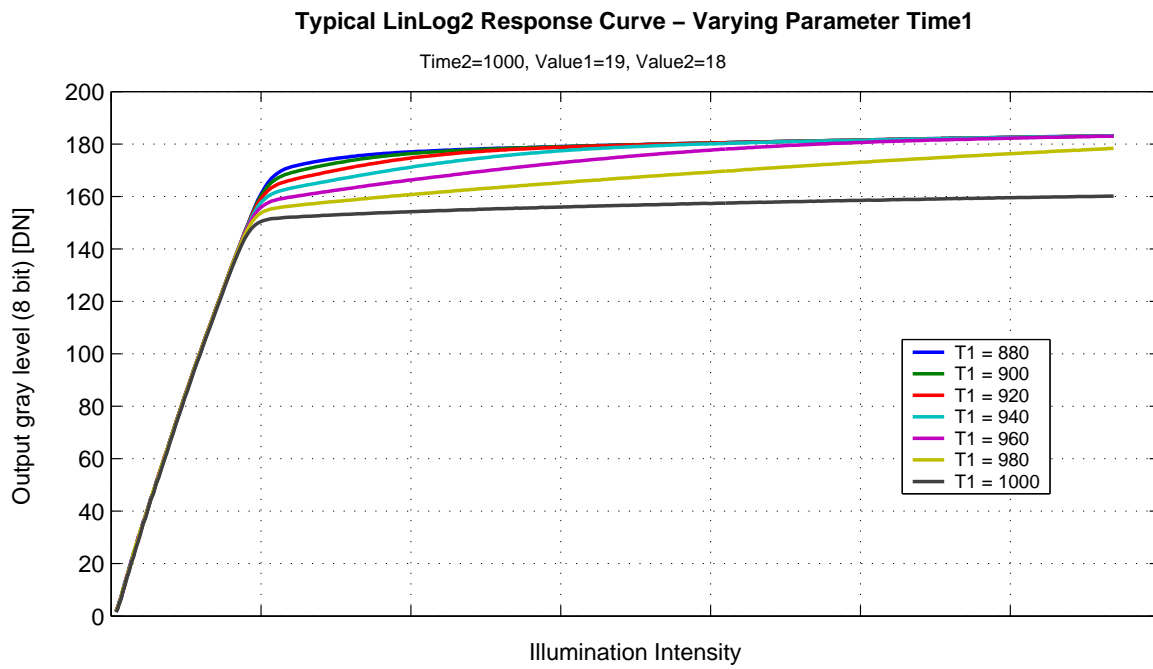

Figure 4.13: Response curve for different LinLog settings in LinLog2 mode

LinLog3

To enable more flexibility the LinLog3 mode with 4 parameters was introduced. Fig. 4.14 shows the timing diagram for the LinLog3 mode and the control parameters.

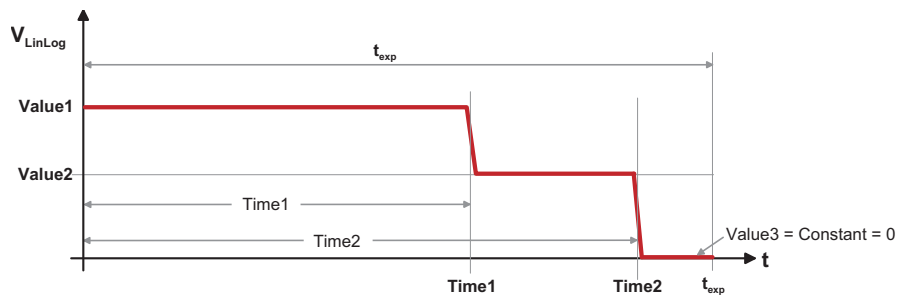

Figure 4.14: Voltage switching in the Linlog3 mode

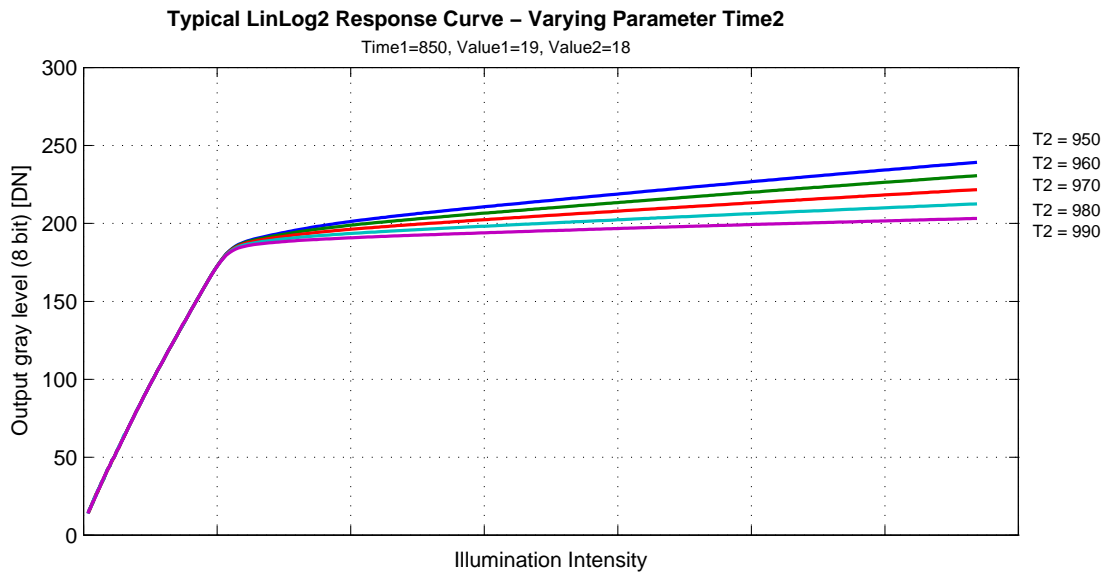

Figure 4.15: Response curve for different LinLog settings in LinLog3 mode

4.3.3 Skimming

Skimming is a Photonfocus proprietary technology to enhance detail in dark areas of an image. Skimming provides an adjustable level of in-pixel gain for low signal levels. It can be used together with LinLog to give a smooth monotonic transfer function from high gain at low levels, through normal linear operation, to logarithmic compression for high signal levels (see Fig. 4.16). The resulting response is similar to a gamma correction.

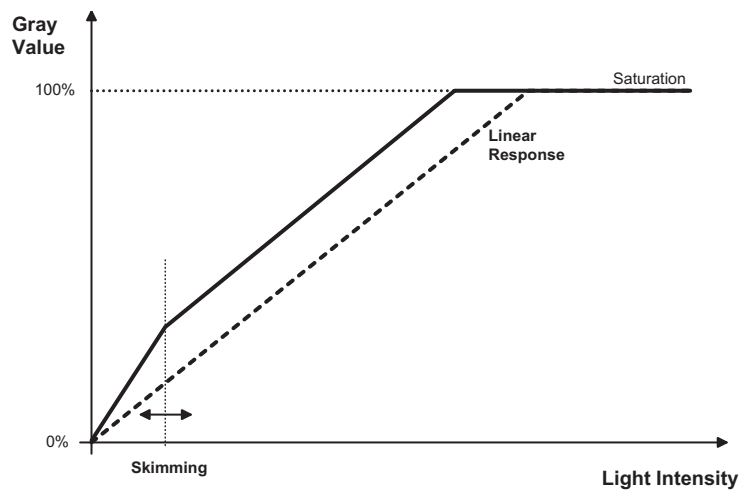



Figure 4.16: Response Curve for different skim settings

4.3.4 Gray Level Transformation (LUT)

Gray level transformation is remapping of the gray level values of an input image to new values. The look-up table (LUT) is used to convert the grayscale value of each pixel in an image into another gray value. It is typically used to implement a transfer curve for contrast expansion. The camera performs a 10-to-8-bit mapping, so that 1024 input gray levels can be mapped to 256 output gray levels. The use of the three available modes is explained in the next sections.

 The output gray level resolution of the look-up table (independent of gain, gamma or user-definded mode) is always 8 bit.

 There are 2 predefined function, which generate a LUT table and transfer it to the camera. For other transfer functions the user can define his own LUT file.

Gain

The 'Gain' mode performs a digital, linear amplification (see Fig. 4.17). It is configurable in the range from 1.0 to 4.0. (e.g. 1.234)

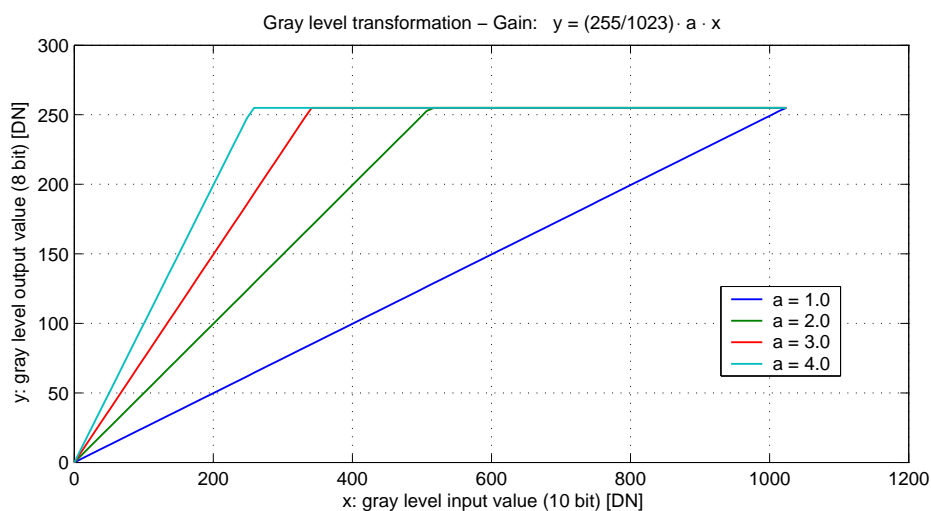

Figure 4.17: Applying a linear gain to an image

Gamma

The 'Gamma' mode performs an exponential amplification, configurable in the range from 0.4 to 4.0. $\gamma > 1.0$ results in an attenuation of the image (see Fig. 4.18), $\gamma < 1.0$ results in an amplification (see Fig. 4.19).

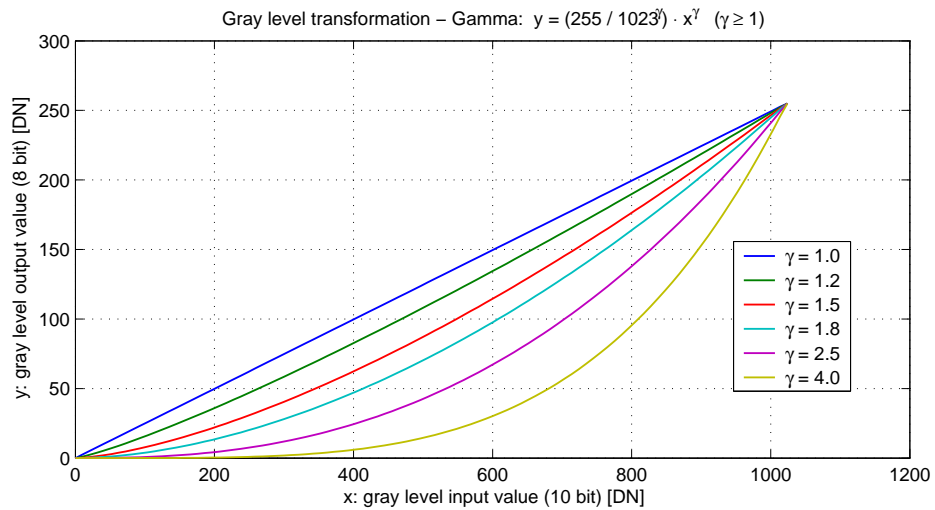

Figure 4.18: Applying gamma correction to an image (gamma > 1)

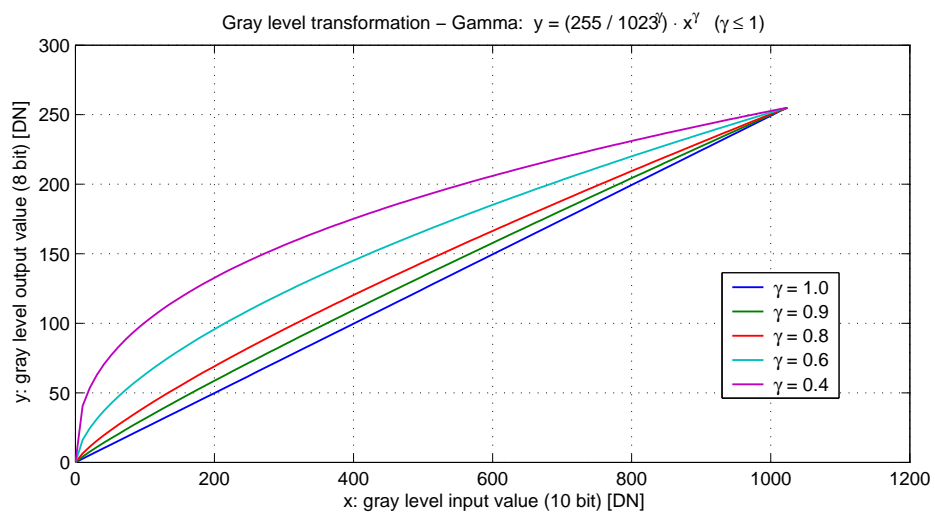

Figure 4.19: Applying gamma correction to an image (gamma < 1)

User-defined Look-up Table

In the 'User' mode, the mapping of input to output gray levels can be configured arbitrarily by the user. There is an example file in the PFRemote folder.

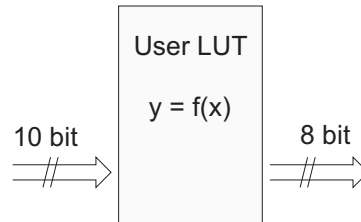

Figure 4.20: Data path through LUT

4.3.5 Test Images

Test images are generated in the camera FPGA, independent of the image sensor. They can be used to check the transmission path from the camera to the frame grabber. Independent from the configured gray level resolution, every possible gray level appears the same number of times in a test image. Therefore, the histogram of the received image must be flat.



A test image is a useful tool to find data transmission errors that are caused most often by a defective cable between camera and frame grabber.



Test images give the correct result at full resolution only.

Ramp

Depending on the configured gray level resolution, the ramp test image outputs a constant pattern with increasing gray level from the left to the right side (see Fig. 4.21).



Figure 4.21: Ramp test images: 8 bit output (left), 10 bit output (middle), 12 bit output (right)

LFSR

The LFSR (linear feedback shift register) test image outputs a constant pattern with a pseudo-random gray level sequence containing every possible gray level that is repeated for every row. In 12 bit mode only a fourth of all possible gray values appear.

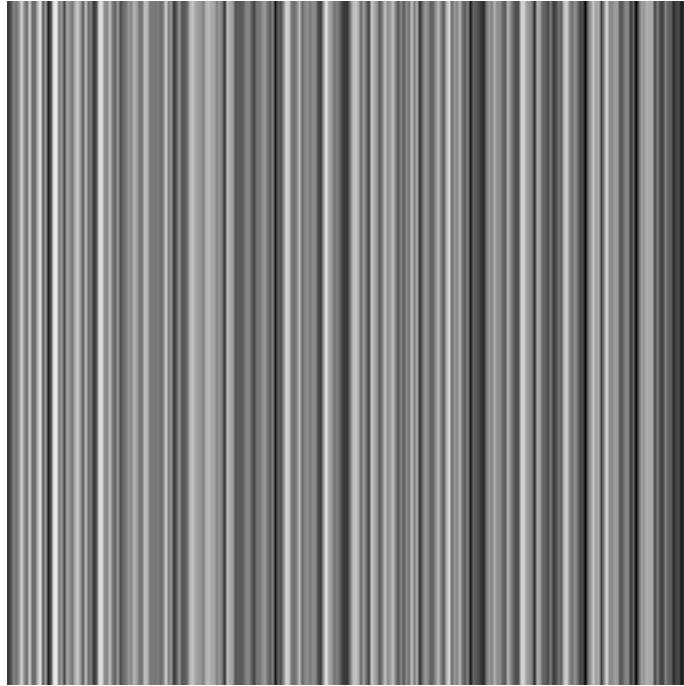



Figure 4.22: LFSR test image

In the histogram you can see that the number of pixels of all gray values are the same. Please refer to application note [AN026] for the calculation and the values of the LFSR test image.

Troubleshooting using the LFSR

To control the quality of your complete imaging system enable the LFSR mode and check the histogram. If your frame grabber application does not provide a real-time histogram, store the image and use a graphics software to display the histogram.

In the LFSR (linear feedback shift register) mode the camera generates a constant test pattern containing all gray levels. If the data transmission is error free, the histogram of the received LFSR test pattern will be flat (Fig. 4.23). On the other hand, a non-flat histogram (Fig. 4.24) indicates problems, that may be caused either by the cable, the connectors or the frame grabber.

-  A possible origin of failure message can be caused by the CameraLink cable which exceeds the maximum length or suffers from severe electromagnetic interference.

-  Some CameraLink cable have predefined direction.

-  The LFSR test works only for an image width of 1024, otherwise the histogram will not be flat.

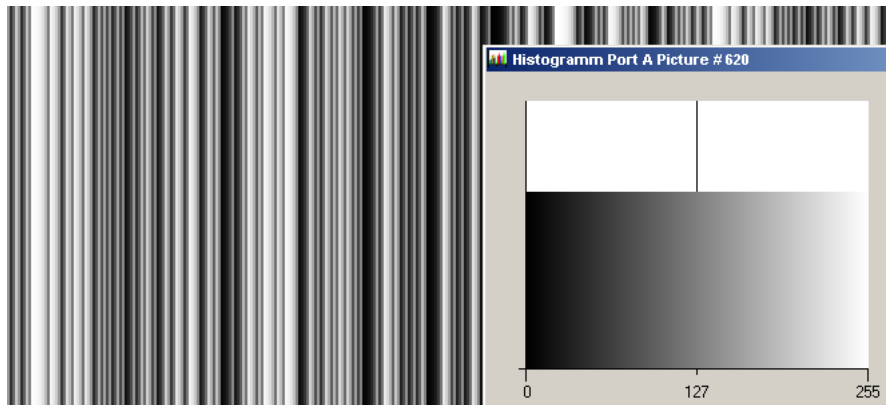

Figure 4.23: LFSR test pattern received at the frame grabber and typical histogram for error-free data transmission

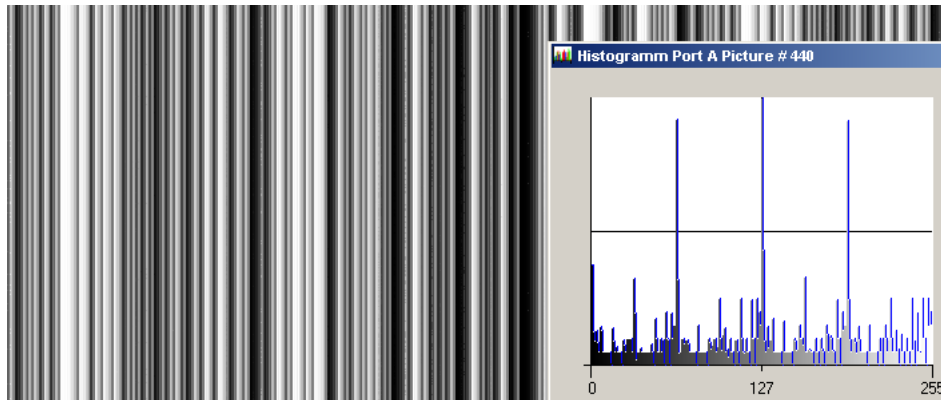

Figure 4.24: LFSR test pattern received at the frame grabber and histogram containing transmission errors



CameraLink cables contain wire pairs, which are twisted in such a way that the cable impedance matches with the LVDS driver and receiver impedance. Excess stress on the cable results in transmission errors which causes distorted images. Therefore, please do not stretch and bend a CameraLink cable.

In robots applications, the stress that is applied to the CameraLink cable is especially high due to the fast movement of the robot arm. For such applications, special drag chain capable cables are available.

4.4 Image Correction

4.4.1 Overview

The MV-D1024E and the MV-D752E camera series possess image pre-processing features, that compensate for non-uniformities caused by the sensor, the lens or the illumination. This method of improving the image quality is generally known as 'Shading Correction' or 'Flat Field Correction' and consists of a combination of offset correction, gain correction and pixel interpolation.



Since the correction is performed in hardware, there is no performance limitation for high frame rates.

The offset correction subtracts a configurable positive or negative value from the live image and thus reduces the fixed pattern noise of the CMOS sensor. In addition, hot pixels can be removed by interpolation. The gain correction can be used to flatten uneven illumination or to compensate shading effects of a lens. Both offset and gain correction work on a pixel-per-pixel basis, i.e. every pixel is corrected separately. For the correction, a black reference and a gray reference image are required. Then, the correction values are determined automatically in the camera.



Do not set any reference images when gain or LUT is enabled!

Correction values of both reference images can be saved into the internal flash memory, but this overwrites the factory presets. Then the reference images that are delivered by factory cannot be restored anymore.

4.4.2 Offset Correction (FPN, Hot Pixels)

The offset correction is based on a black reference image, which is taken at no illumination (e.g. lens aperture completely closed). The black reference image contains the fixed-pattern noise of the sensor, which can be subtracted from the live images in order to minimise the static noise.

Offset correction algorithm

After configuring the camera with a black reference image, the camera is ready to apply the offset correction:

1. Determine the average value of the black reference image.
2. Subtract the black reference image from the average value.
3. Mark pixels that have a gray level higher than 1008 DN (@ 12 bit) as hot pixels.
4. Store the result in the camera as the offset correction matrix.
5. During image acquisition, subtract the correction matrix from the acquired image and interpolate the hot pixels (see Section 4.4.2).

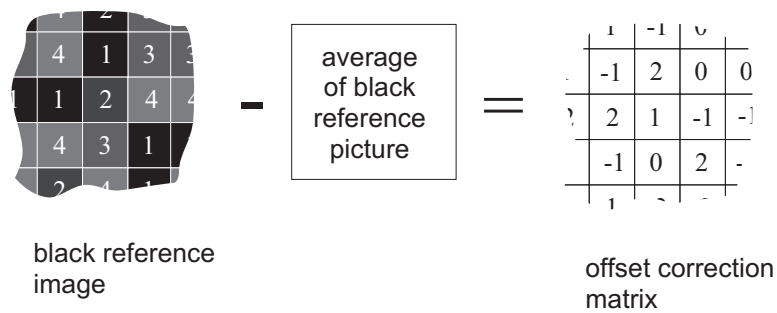

Figure 4.25: Offset correction

How to Obtain a Black Reference Image

In order to improve the image quality, the black reference image must meet certain demands.

- The black reference image must be obtained at no illumination, e.g. with lens aperture closed or closed lens opening.
- It may be necessary to adjust the black level offset of the camera. In the histogram of the black reference image, ideally there are no gray levels at value 0 DN after adjustment of the black level offset. All pixels that are saturated black (0 DN) will not be properly corrected (see Fig. 4.26). The peak in the histogram should be well below the hot pixel threshold of 1008 DN @ 12 bit.
- Camera settings such as exposure time, LinLog, skimming and digital gain may influence the gray level. Therefore, for best results the camera settings of the black reference image must be identical with the camera settings of the corrected image.

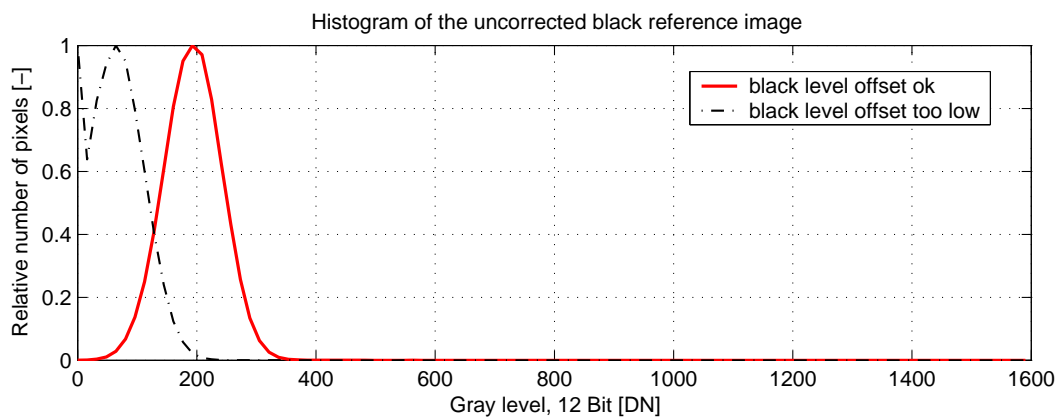

Figure 4.26: Histogram of a proper black reference image for offset correction

Hot pixel correction

Every pixel that exceeds a certain threshold in the black reference image is marked as a hot pixel. If the hot pixel correction is switched on, the camera replaces the value of a hot pixel by an average of its neighbour pixels (see Fig. 4.27).

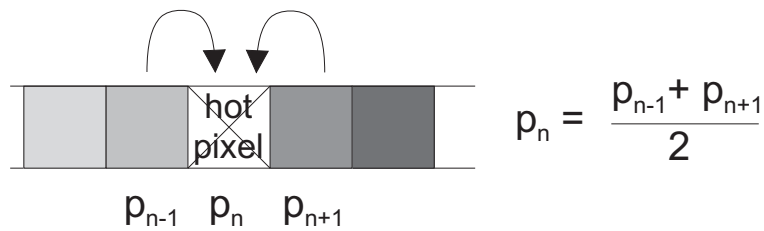



Figure 4.27: Hot pixel interpolation

4.4.3 Gain Correction

The gain correction is based on a gray reference image, which is taken at uniform illumination to give an image with a mid gray level.

 Gain correction is not a trivial feature. The quality of the gray reference image is crucial for proper gain correction.

Gain correction algorithm

After configuring the camera with a black and gray reference image, the camera is ready to apply the gain correction:

1. Determine the average value of the gray reference image.
2. Subtract the offset correction matrix from the gray reference image.
3. Divide the average value by the offset corrected gray reference image.
4. Pixels that have a gray level bigger than a certain threshold are marked as hot pixels.
5. Store the result in the camera as the gain correction matrix.
6. During image acquisition, multiply the gain correction matrix from the offset-corrected acquired image and interpolate the hot pixels (see Section 4.4.2).

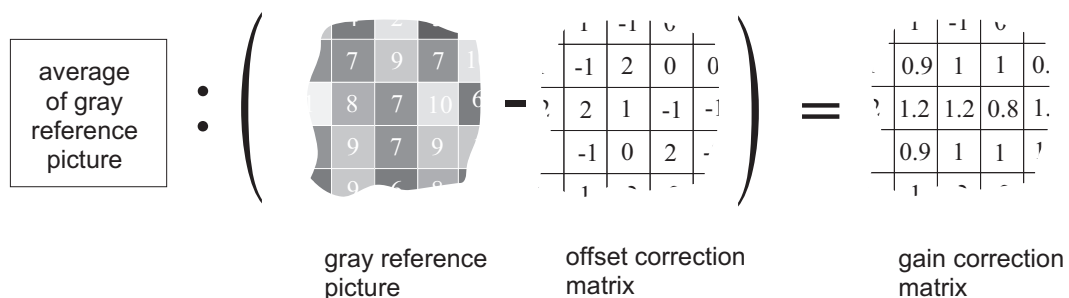



Figure 4.28: Gain Correction

 Gain correction always needs an offset correction matrix, so the offset correction has to be performed before the gain correction.

How to Obtain a Gray Reference Image

In order to improve the image quality, the gray reference image must meet certain demands.

- The gray reference image must be obtained at uniform illumination.
 -  Use a high quality light source that delivers uniform illumination. Standard illumination will not be appropriate.
- When looking at the histogram of the gray reference image, ideally there are no gray levels at full scale (4095 DN @ 12 bit). All pixels that are saturated white will not be properly corrected (see Fig. 4.29).
- Camera settings such as exposure time, LinLog, skimming and digital gain may influence the gray level. Therefore, the camera settings of the gray reference image must be identical with the camera settings of the corrected image.

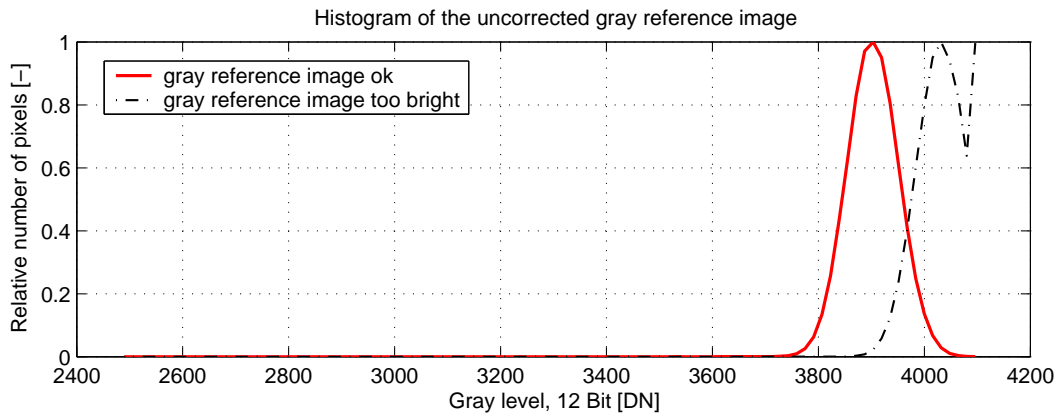

Figure 4.29: Proper gray reference image for gain correction

4.4.4 Corrected Image

Offset, gain and hot pixel correction can be switched on separately. The following configurations are possible:

- No correction
- Offset correction only
- Offset and hot pixel correction
- Hot pixel correction only
- Offset and gain correction
- Offset, gain and hot pixel correction

In addition, the black reference image and gray reference image that are currently stored in the camera RAM can be output.

$$\left(\begin{array}{c} \text{current image} \\ \begin{array}{|c|c|c|c|} \hline 5 & 7 & 5 & 3 \\ \hline 6 & 6 & 7 & 4 \\ \hline 6 & 5 & 6 & \\ \hline 7 & 4 & 6 & \\ \hline \end{array} \end{array} \right) - \begin{array}{|c|c|c|c|} \hline 1 & -1 & 0 & 0 \\ \hline -1 & 2 & 0 & 0 \\ \hline 2 & 1 & -1 & -1 \\ \hline -1 & 0 & 2 & - \\ \hline 1 & - & - & - \\ \hline \end{array} \cdot \begin{array}{|c|c|c|c|} \hline 1 & -1 & 0 & 0 \\ \hline 0.9 & 1 & 1 & 0 \\ \hline 1.2 & 1.2 & 0.8 & 1 \\ \hline 0.9 & 1 & 1 & 1 \\ \hline 1 & - & - & - \\ \hline \end{array} = \begin{array}{c} \text{corrected image} \\ \begin{array}{|c|c|c|c|} \hline 5 & 5 & 5 & 3 \\ \hline 5 & 6 & 6 & 4 \\ \hline 6 & 5 & 4 & \\ \hline 7 & 4 & 6 & \\ \hline \end{array} \end{array}$$

Figure 4.30: Corrected image

Table 4.2 shows the maximum values of the correction matrices, i.e. the error range that the offset and gain algorithm can correct.

	minimum	maximum
Offset correction	-508 DN @ 12 bit	+508 DN @ 12 bit
Gain correction	0.42	2.67

Table 4.2: Offset and gain correction ranges

4.5 Reduction of Image Size

With Photonfocus cameras there are several possibilities to focus on the interesting parts of an image, thus reducing the data rate and increasing the frame rate. The most commonly used feature is Region of Interest (ROI).

4.5.1 Region of Interest (ROI)

Some applications do not need full image resolution (e.g. 1024x1024 pixels). By reducing the image size to a certain region of interest (ROI), the frame rate can be drastically increased. A region of interest can be almost any rectangular window and is specified by its position within the full frame and its width and height. Fig. 4.31 gives some possible configurations for a region of interest, and Table 4.3 shows some numerical examples of how the frame rate can be increased by reducing the ROI.



Both reductions in x- and y-direction result in a higher frame rate.

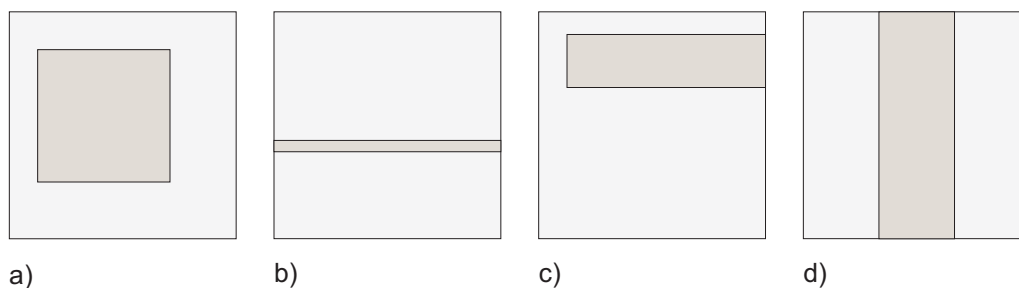

Figure 4.31: ROI configuration examples

ROI Dimension	MV-D1024E-40	MV-D1024E-80	MV-D1024E-160
1024 x 1024	37 fps	74 fps	149 fps
512 x 512	149 fps	293 fps	586 fps
256 x 256	585 fps	1127 fps	2230 fps
128 x 128	2230 fps	4081 fps	7843 fps
128 x 16	15 000 fps	23041 fps	37453 fps

Table 4.3: Frame rates of different ROI settings (exposure time 10 μ s; correction off, CFR off, skimming off and sequential readout mode).

Exposure time	MV-D1024E-40	MV-D1024E-80	MV-D1024E-160
10 μ s	37 fps	74 / 74 fps	149 / 148 fps
100 μ s	37 fps	74 / 74 fps	147 / 146 fps
500 μ s	37 fps	72 / 72 fps	139 / 139 fps
1 ms	36 fps	69 / 72 fps	130 / 139 fps
2 ms	35 fps	65 / 72 fps	115 / 140 fps
5 ms	31 fps	54 / 72 fps	85 / 140 fps
10 ms	27 fps	42 / 72 fps	60 / 99 fps
12 ms	26 fps	39 / 72 fps	53 / 82 fps

Table 4.4: Frame rate of different exposure times, [sequential readout mode / simultaneous readout mode], resolution 1024x1024 pixel (correction off, CFR off and skimming off).



The MV-D1024E-40 does not support the simultaneous readout mode.

Calculation of the maximum frame rate

The frame rate mainly depends of the exposure time and readout time. The frame rate is the inverse of the frame time. In the following formulars the minimum frame time is calculated. When using CFR mode the frame time can get extended.

$$\text{fps} = \frac{1}{t_{\text{frame}}}$$

Calculation of the frame time (sequential mode)

$$t_{\text{frame}} \geq t_{\text{exp}} + t_{\text{ro}} + t_{\text{proc}} + t_{\text{RAM}}$$

Calculation of the frame time (simultaneous mode)

$$t_{\text{frame}} \geq \max(t_{\text{exp}} + 76 \mu\text{s}, t_{\text{ro}} + 476 \mu\text{s}) + t_{\text{RAM}}$$

$$t_{\text{ro}} = t_{\text{CLK}} * (P_y * (\frac{P_x}{t_{\text{taps}}} + \text{LP}) + \text{LP})$$

$$t_{\text{proc}} = t_{\text{Normal}} + t_{\text{CFR}} + t_{\text{FPN}} + t_{\text{Skim}}$$

$$t_{\text{RAM}} = \frac{1}{128} * (t_{\text{ro}} + 1375 \text{ ns}) - (t_{\text{exp}} + t_{\text{proc}})$$



When the result of t_{RAM} is negative, set it to 0.

t_{frame}	frame time
t_{exp}	exposure time
t_{ro}	readout time
t_{proc}	processing time
t_{RAM}	RAM refresh time
t_{Normal}	constant latency
t_{CFR}	constant frame rate latency, only when CFR is enabled
t_{FPN}	correction latency, only when correction is enabled
t_{Skim}	skim latency, only when Skimming is enabled
t_{CLK}	pixel clock
taps	CameraLink taps
P_X	number of pixels in x-direction
P_Y	number of pixels in y-direction (+1, for MV-D1024E-80 and MV-D1024E-160)
LP	line pause, constant LP = 8 for all models

	MV-D1024E-40	MV-D1024E-80	MV-D1024E-160
t_{exp}	10 μs - 419 ms	10 μs - 838 ms	25 μs - 419 ms
t_{Normal}	1975 ns	2600 ns	1300 ns
t_{CFR}	850 ns	0	0
t_{FPN}	150 ns	0	0
t_{Skim}	51.125 μs	101.6 μs	50.8 μs
t_{CLK}	25 ns	25 ns	12.5 ns
taps	1	2	2
P_Y	Window H	Window H + 1	Window H + 1

Table 4.5: Camera specific values for frame time calculations



A calculator for calculating the maximum frame rate is available in the support area of the Photonfocus website.

4.5.2 Multiple Regions of Interest

The MV-D1024E camera series can handle up to 16 different regions of interest. This feature can be used to reduce the image data and increase the frame rate. An application example for using multiple regions of interest (MROI) is a laser triangulation system with several laser lines. The multiple ROIs are joined together and form a single image, which is transferred to the frame grabber.

An ROI is defined by its starting value in y-direction and its height. Every ROI within a MROI must be of the same width. The maximum frame rate in MROI mode depends on the number of rows and columns being read out. Overlapping ROIs are allowed. See Section 4.5.1 for information on the calculation of the maximum frame rate.

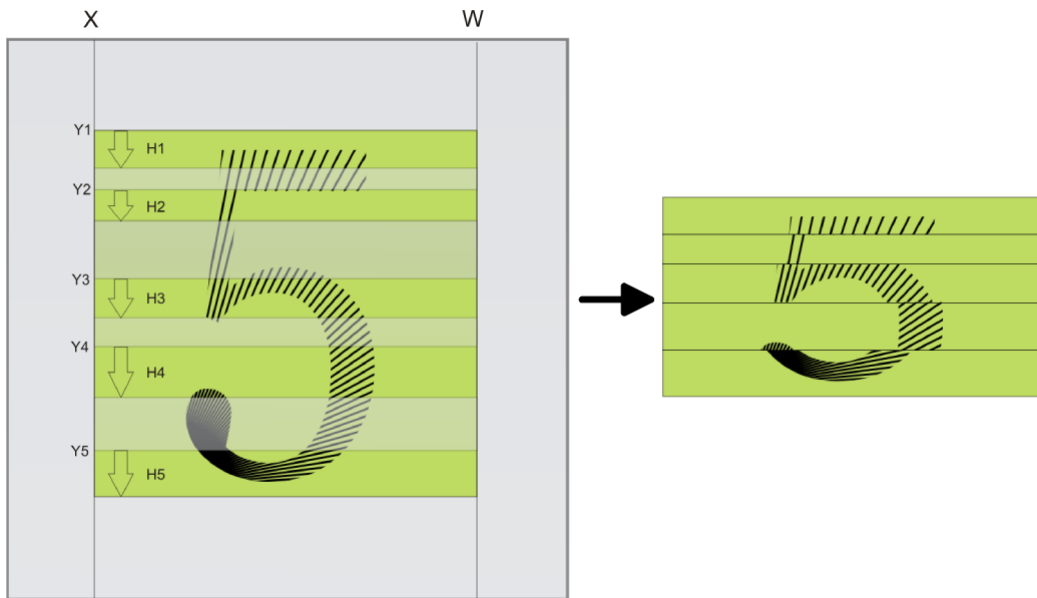



Figure 4.32: Multiple Regions of Interest with 5 ROIs

4.5.3 Decimation

Decimation reduces the number of pixels in x- and y-direction. Decimation can also be used together with ROI or MROI. Decimation in y-direction transfers every n^{th} row only and directly results in reduced read-out time and higher frame rate respectively. Decimation in x-direction transfers every pixel of a row, but uses the CameraLink DVAL (data valid) signal to indicate which pixels to mask (see 4.33). Therefore it cannot be used to increase the frame rate.

 The MV-D1024E-80 and MV-D1024E-160 cameras do not support decimation in x-direction.

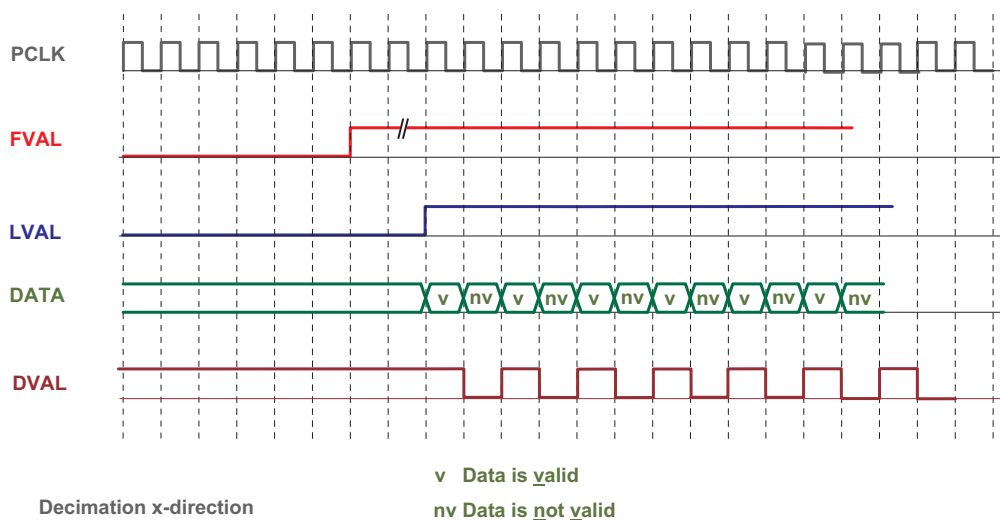

Figure 4.33: Decimation in x-direction uses the CameraLink DVAL signal



Please consult the documentation of your frame grabber on how to configure the frame grabber such that it interprets the DVAL signal.

4.6 External Trigger

An external trigger is an event that starts an exposure. The trigger signal is either generated on the frame grabber (soft-trigger) or comes from an external device such as a light barrier. If a trigger signal is applied to the camera before the earliest time for the next trigger, this trigger will be ignored. The camera property `Counter.MissedTrigger` stores the number of trigger events which were ignored.

4.6.1 Trigger Source

The trigger signal can be configured to be active high or active low. One of the following trigger sources can be used:

Interface Trigger In the interface trigger mode, the trigger signal is applied to the camera by the CameraLink interface.

I/O Trigger In the I/O trigger mode, the trigger signal is applied directly to the camera by the power supply connector (over an optocoupler).

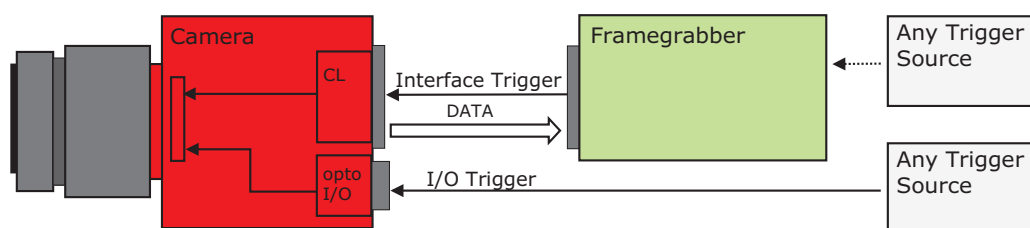

Figure 4.34: Trigger Inputs

4.6.2 Trigger Mode

Depending on the trigger mode, the exposure time can be determined either by the camera or by the trigger signal itself:

Camera-controlled Exposure In this trigger mode the exposure time is defined by the camera.







For an active high trigger signal, the camera starts the exposure with a positive trigger edge and stops it when the preprogrammed exposure time has elapsed. The exposure time is defined by the software.

Level-controlled Exposure In this trigger mode the exposure time is defined by the pulse width of the trigger pulse. For an active high trigger signal, the camera starts the exposure with the positive edge of the trigger signal and stops it with the negative edge.



Level-controlled Exposure is not available in simultaneous readout mode.

Figure 4.35 gives an overview over the available trigger modes. The signal `ExSync` stands for the trigger signal, which is provided either through the interface or the I/O trigger. For more information and the respective timing diagrams see Section 5.4

	Polarity Active High		Polarity Active Low	
	Exposure Start	Exposure Stop	Exposure Start	Exposure Stop
Camera controlled exposure	 ExSync	Camera	 ExSync	Camera
Level controlled exposure	 ExSync	 ExSync	 ExSync	 ExSync



 Rising Edge
 Falling Edge

Figure 4.35: Trigger Inputs

4.6.3 Trigger Delay

Programmable delay in milliseconds between the incoming trigger edge and the start of the exposure. This feature may be required to synchronize to external strobe with the exposure of the camera.

4.7 Strobe Output

The strobe output is an opto-isolated output located on the power supply connector that can be used to trigger a strobe. The strobe output can be used both in free-running and in trigger mode. There is a programmable delay available to adjust the strobe pulse to your application.



The strobe output needs a separate power supply. Please see Section 5.1.3 for more information.

4.8 Configuration of the OEM interface

The OEM camera modules can be controlled by the user via a RS232 compatible asynchronous serial interface. The interface is accessible via the board connectors.

Hardware Interface

5.1 Connectors

5.1.1 CameraLink Connector

The CameraLink cameras are interfaced to external components via

- a CameraLink connector, which is defined by the CameraLink standard as a 26 pin, 0.5" Mini Delta-Ribbon (MDR) connector to transmit configuration, image data and trigger.
- a subminiature connector for the power supply, 7-pin Binder series 712.

The connectors are located on the back of the camera. Fig. 5.1 shows the plugs and the status LED which indicates camera operation.

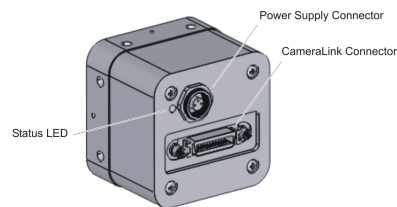

Figure 5.1: Rear view of the CameraLink camera

The CameraLink interface and connector are specified in [CL]. For further details including the pinout please refer to Appendix 11. This connector is used to transmit configuration, image data and trigger signals.

5.1.2 Power Supply

The camera requires a single voltage input (see Table 3.4). The camera meets all performance specifications using standard switching power supplies, although well-regulated linear power supplies provide optimum performance.



It is extremely important that you apply the appropriate voltages to your camera. Incorrect voltages will damage the camera.



A suitable power supply is available from Photonfocus.

For further details including the pinout please refer to Appendix 11.

5.1.3 Trigger and Strobe Signals

The power connector contains an external trigger input and a strobe output.



The input voltage to the TRIGGER pin must not exceed +15V DC, to avoid damage to the internal optocoupler!

In order to use the strobe output, the internal optocoupler must be powered with 5 .. 15 V DC. The STROBE signal is an open-collector output, therefore, the user must connect a pull-up resistor (see Table 5.1) to STROBE_VDD (5 .. 15 V DC) as shown in Fig. 5.2. This resistor should be located directly at the signal receiver.

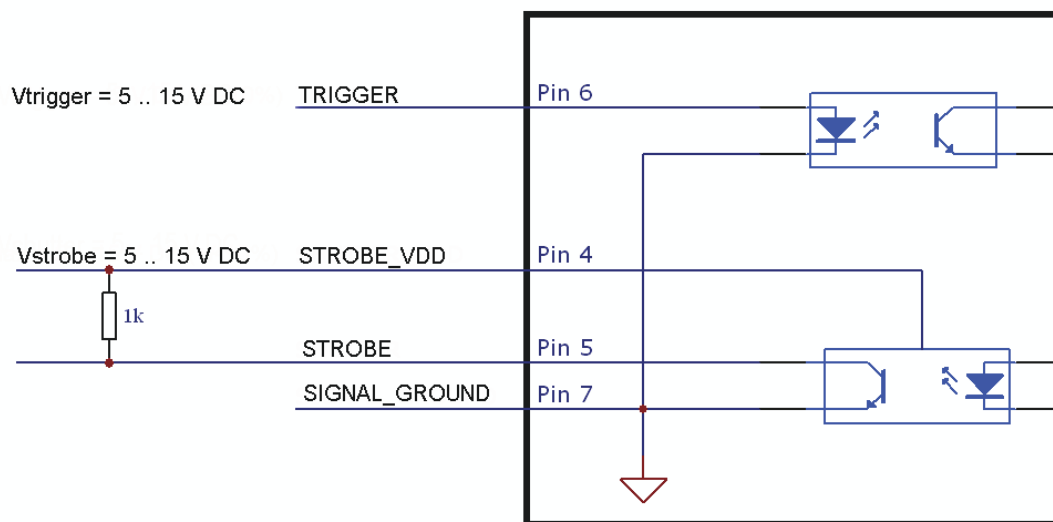

Figure 5.2: Circuit for the trigger input and strobe output signals



The maximum sink current of the STROBE pin is 8 mA. *Do not connect inductive or capacitive loads*, such loads may result in damage of the optocoupler! If the application requires this, please use voltage suppressor diodes in parallel with this components to protect the opto coupler.

STROBE_VDD	Pull-up Resistor
15 V	> 3.9 kOhm
10 V	> 2.7 kOhm
8V	> 2.2 kOhm
7V	> 1.8 kOhm
5V	> 1.0 kOhm

Table 5.1: Pull-up resistor for strobe output and different voltage levels

5.1.4 Status Indicator (CameraLink cameras)

A dual-color LED on the back of the camera gives information about the current status of the CameraLink cameras.

LED Green	Green when an image is output. At slow frame rates, the LED blinks with the FVAL signal. At high frame rates the LED changes to an apparently continuous green light, with intensity proportional to the ratio of readout time over frame time.
LED Red	Red indicates an active serial communication with the camera.

Table 5.2: Meaning of the LED of the CameraLink cameras

5.2 CameraLink Data Interface

The CameraLink standard contains signals for transferring the image data, control information and the serial communication.

Data signals: CameraLink data signals contain the image data. In addition, handshaking signals such as FVAL, LVAL and DVAL are transmitted over the same physical channel.

Camera control information: Camera control signals (CC-signals) can be defined by the camera manufacturer to provide certain signals to the camera. There are 4 CC-signals available and all are unidirectional with data flowing from the frame grabber to the camera. For example, the external trigger is provided by a CC-signal (see Table 5.3 for the CC assignment).

CC1	EXSYNC	External Trigger. May be generated either by the frame grabber itself (software trigger) or by an external event (hardware trigger).
CC2	CTRL0	Control0. This signal is reserved for future purposes and is not used.
CC3	CTRL1	Control1. This signal is reserved for future purposes and is not used.
CC4	CTRL2	Control2. This signal is reserved for future purposes and is not used.

Table 5.3: Summary of the Camera Control (CC) signals as used by Photonfocus

Pixel clock: The pixel clock is generated on the camera and is provided to the frame grabber for synchronisation.

Serial communication: A CameraLink camera can be controlled by the user via a RS232 compatible asynchronous serial interface. This interface is contained within the CameraLink interface and is physically not directly accessible. Refer to Section 4.8 for more information.

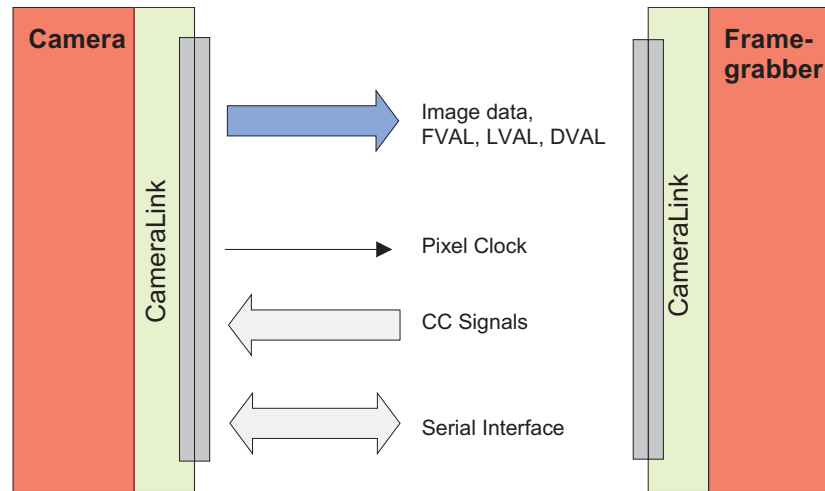

Figure 5.3: 1-tap CameraLink system

The frame grabber needs to be configured with the proper tap and resolution settings, otherwise the image will be distorted or not displayed with the correct aspect ratio. Refer to Section 3.4 for a summarised table of frame grabber relevant specifications. Fig. 5.3 shows symbolically a 1-tap system. For more information about taps refer to [AN021] on the Photonfocus website.

5.3 Read-out Timing

5.3.1 Free running Mode

Sequential readout timing

By default, the camera is in free running mode and delivers images without any external control signals. The sensor is operated in sequential readout mode, which means that the sensor is read out after the exposure time. Then the sensor is reset, a new exposure starts and the readout of the image information begins again. The data is output on the rising edge of the pixel clock. The signals FRAME_VALID (FVAL) and LINE_VALID (LVAL) mask valid image information. The signal SHUTTER indicates the active exposure period of the sensor and is shown for clarity only.

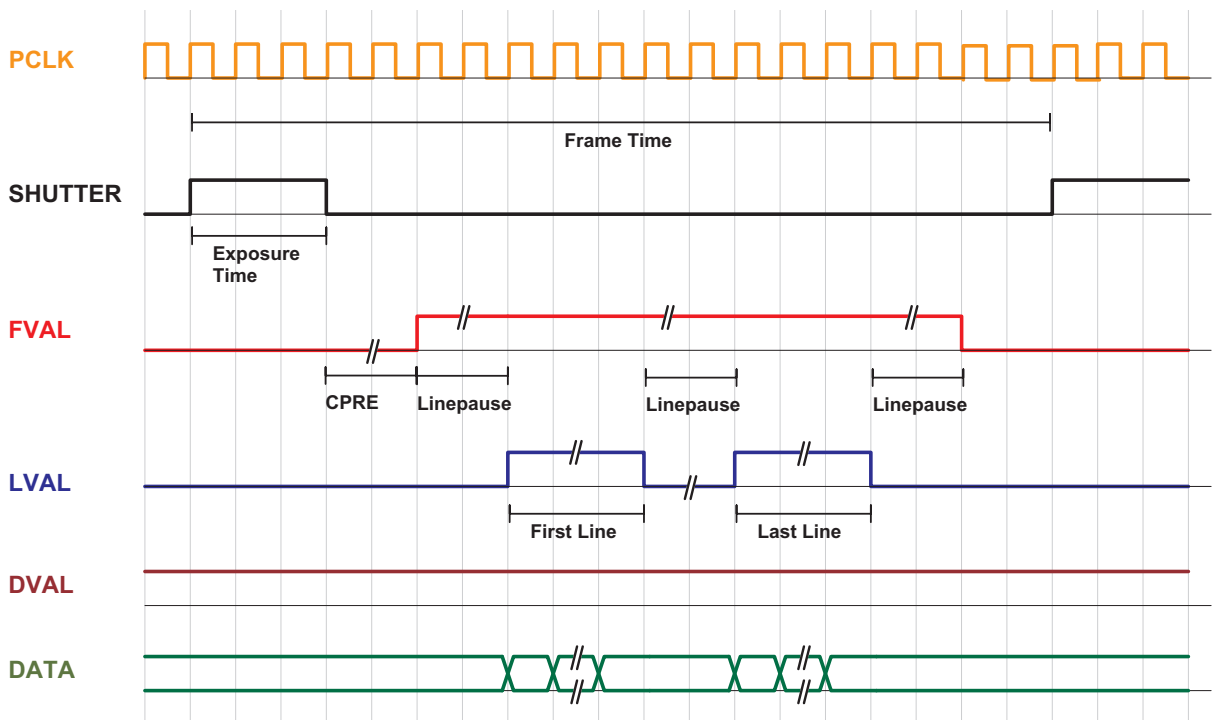

Figure 5.4: Timing diagram sequential readout mode

Simultaneous readout timing

To achieve highest possible frame rates, the camera must be set to "Free-running mode" with simultaneous readout. The camera continuously delivers images as fast as possible. Exposure time of the next image can start during the readout time of the current image. The data is output on the rising edge of the pixel clock. The signals FRAME_VALID (FVAL) and LINE_VALID (LVAL) mask valid image information. The signal SHUTTER indicates the active integration phase of the sensor and is shown for clarity only.

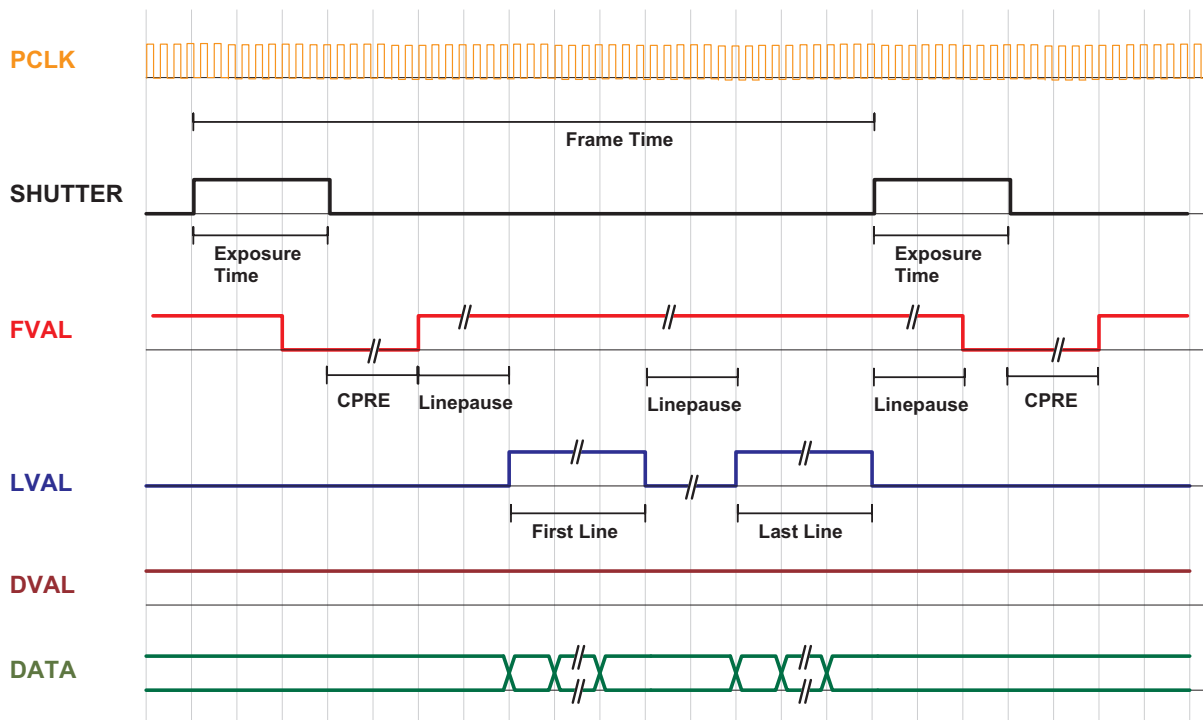

Figure 5.5: Timing diagram simultaneous readout mode (readout time > exposure time)

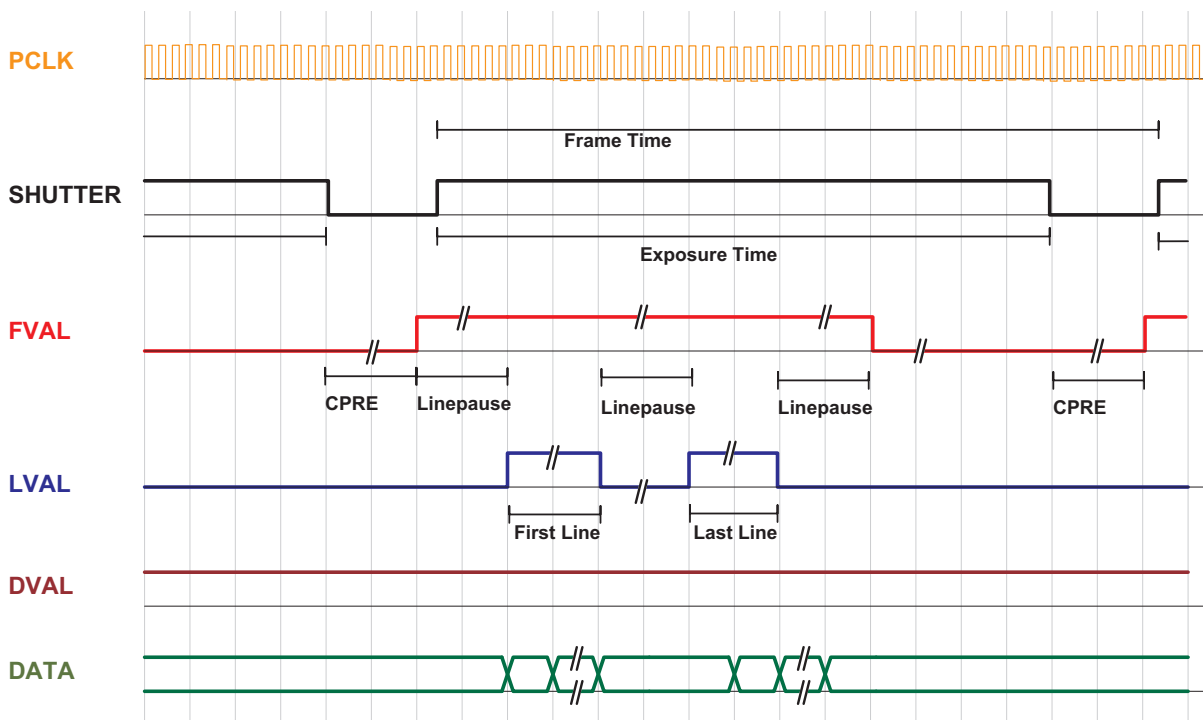

Figure 5.6: Timing diagram simultaneous readout mode (readout time < exposure time)

Frame time	Frame time is the inverse of frame rate.
Exposure time	Period during which the the pixels are integrating the incoming light.
PCLK	Pixel clock on CameraLink interface.
SHUTTER	Internal signal, shown only for clarity. Is 'high' during the exposure time.
FVAL (Frame Valid)	Is 'high' while the data of one whole frame are transferred.
LVAL (Line Valid)	Is 'high' while the data of one line are transferred. Example: To transfer an image with 640x480 pixels, there are 480 LVAL within one FVAL active high period. One LVAL lasts 640 pixel clock cycles.
DVAL (Data Valid)	Is 'high' while data are valid.
DATA	Transferred pixel values. Example: For a 100x100 pixel image, there are 100 values transferred within one LVAL active high period, or 100*100 values within one FVAL period.
Line pause	Delay before the first line and after every following line when reading out the image data.

Table 5.4: Explanation of control and data signals used in the timing diagram

These terms will be used also in the timing diagrams of Section 5.4.

5.3.2 Constant Frame Rate Mode (CFR)

When the camera is in constant frame rate mode, the frame rate can be varied up to the maximum frame rate. Thus, fewer images can be acquired than determined by the frame time. When constant frame rate is switched off, the camera outputs images with maximum speed, depending on the exposure time and the read-out time. The frame rate depends directly on the exposure time.



Constant Frame Rate mode is not available together with external trigger mode.

5 Hardware Interface

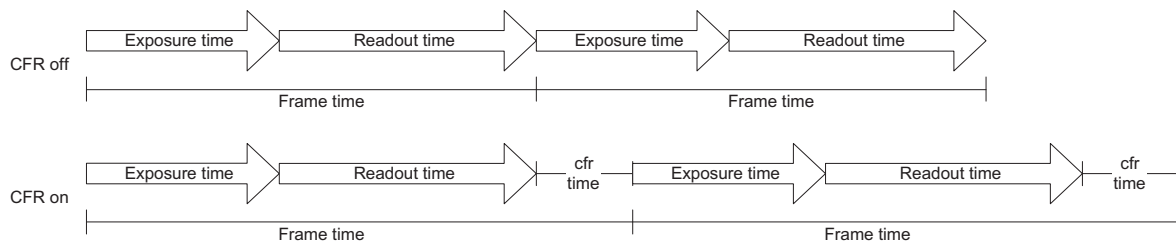

Figure 5.7: Constant Frame Rate with sequential readout mode

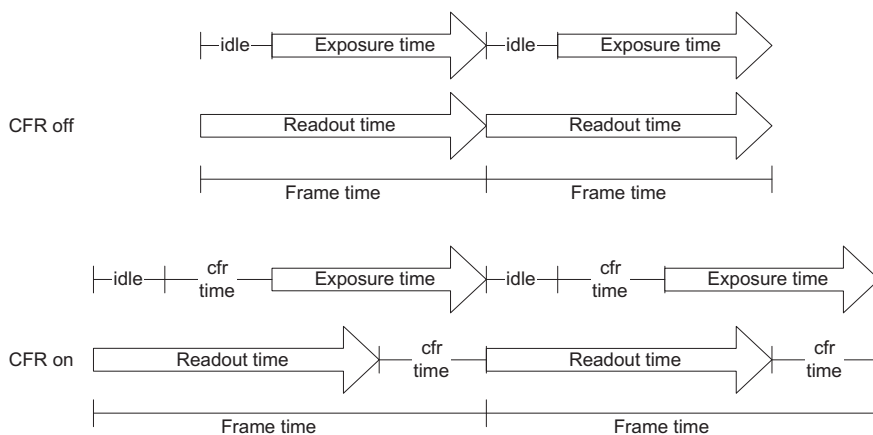

Figure 5.8: Constant Frame Rate with simultaneous readout mode (readout time > exposure time)

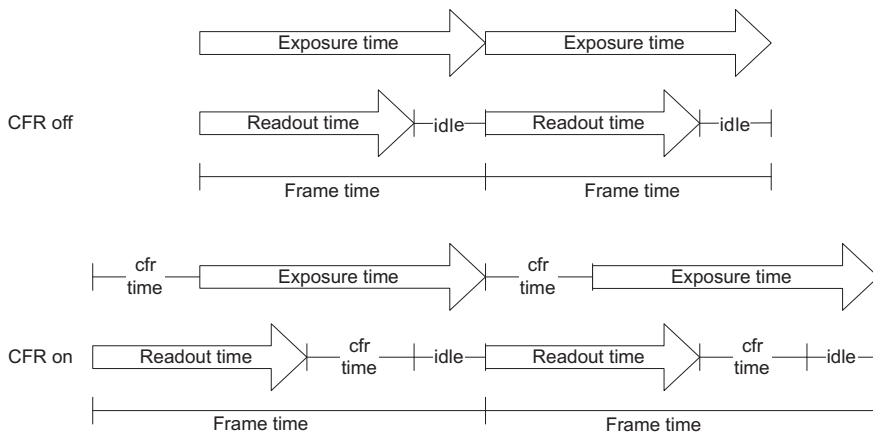

Figure 5.9: Constant Frame Rate with simultaneous readout mode (readout time < exposure time)

5.4 Trigger

5.4.1 Trigger Modes

The following sections show the timing diagram for the trigger modes. The signal ExSync denotes the trigger signal that is provided either by the interface trigger or the I/O trigger (see Section 4.6). The other signals are explained in Table 5.4.

Camera-controlled Exposure

In the camera-controlled trigger mode, the exposure is defined by the camera and is configurable by software. For an active high trigger signal, the image acquisition begins with the rising edge of the trigger signal. The image is read out after the pre-configured exposure time. After the readout, the sensor returns to the reset state and the camera waits for a new trigger pulse (see Fig. 5.10).

The data is output on the rising edge of the pixel clock, the handshaking signals FRAME_VALID (FVAL) and LINE_VALID (LVAL) mask valid image information. The signal SHUTTER in Fig. 5.10 indicates the active integration phase of the sensor and is shown for clarity only.

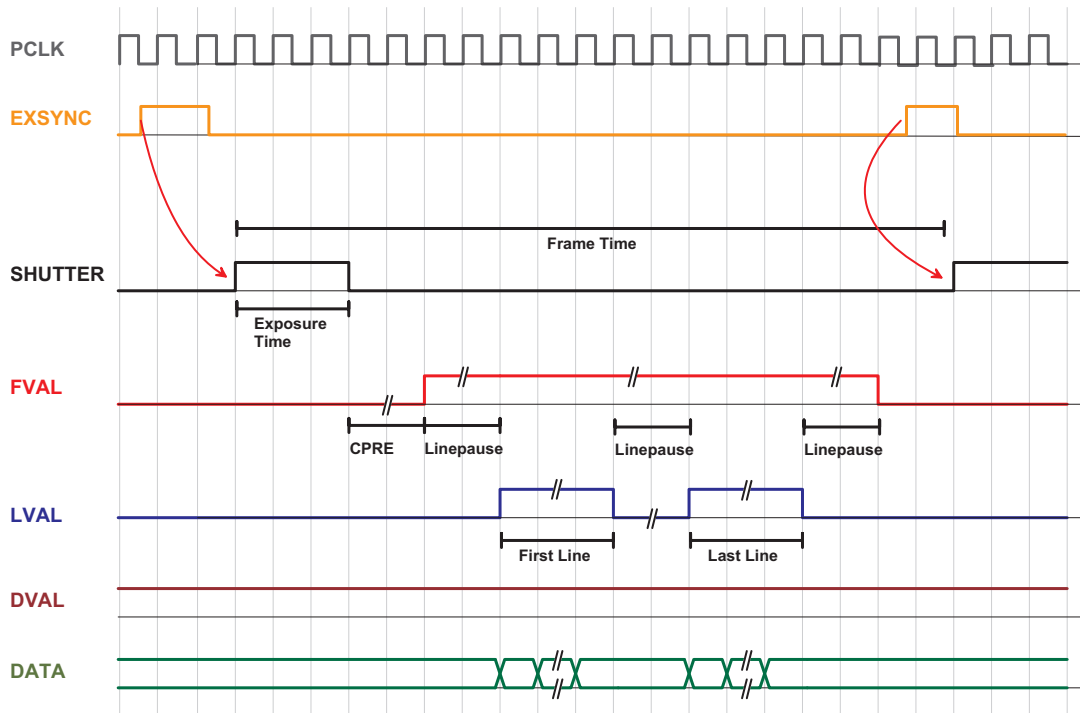

Figure 5.10: Trigger timing diagram for camera controlled exposure

Level-controlled Exposure

In the level-controlled trigger mode, the exposure time is defined by the pulse width of the external trigger signal. For an active high trigger signal, the image acquisition begins with the rising edge and stops with the falling edge of the external trigger signal. Then the image is read out. After that, the sensor returns to the idle state and the camera waits for a new trigger pulse (see Fig. 5.11). The data is output on the rising edge of the pixel clock, the handshaking signals FRAME_VALID (FVAL) and LINE_VALID (LVAL) mask valid image information. The signal SHUTTER in Fig. 5.11 indicates the active integration phase of the sensor and is shown for clarity only.



Level-controlled exposure is supported in simultaneous readout mode.

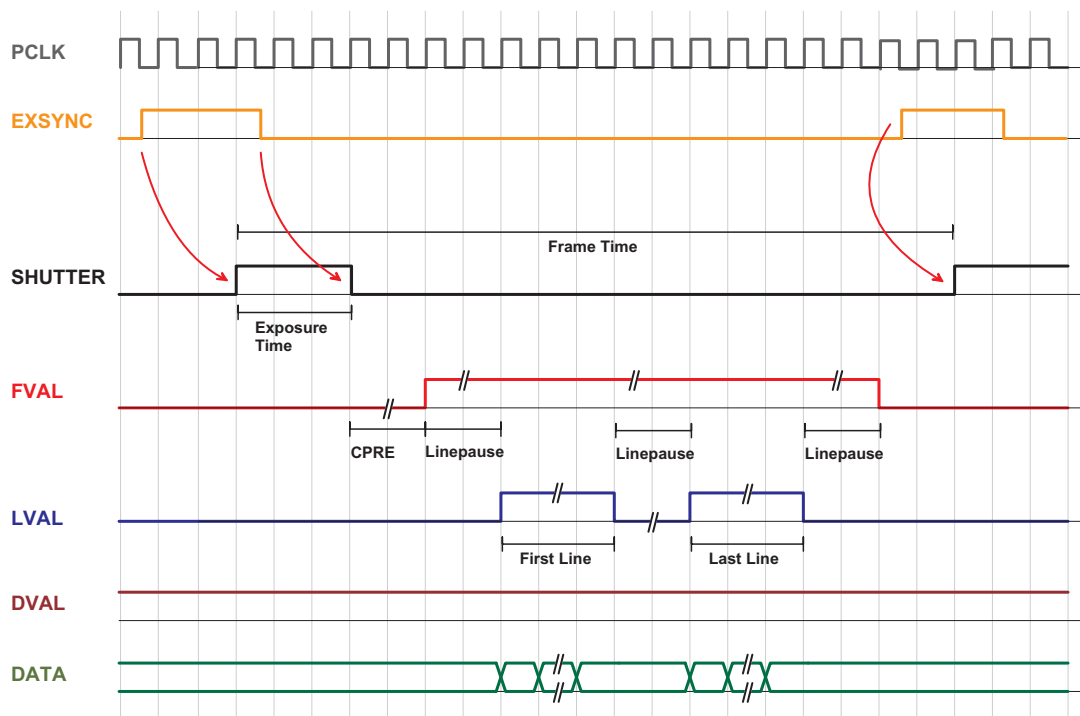

Figure 5.11: Trigger timing diagram for level controlled exposure

5.4.2 Trigger Delay

The total delay between the trigger edge and the camera exposure consists of the delay in the frame grabber and the camera (Fig. 5.12). Usually, the delay in the frame grabber is relatively large to avoid accidental triggers caused by voltage spikes (see Fig. 5.13). The trigger can also be delayed by the property `Trigger.Delay`.

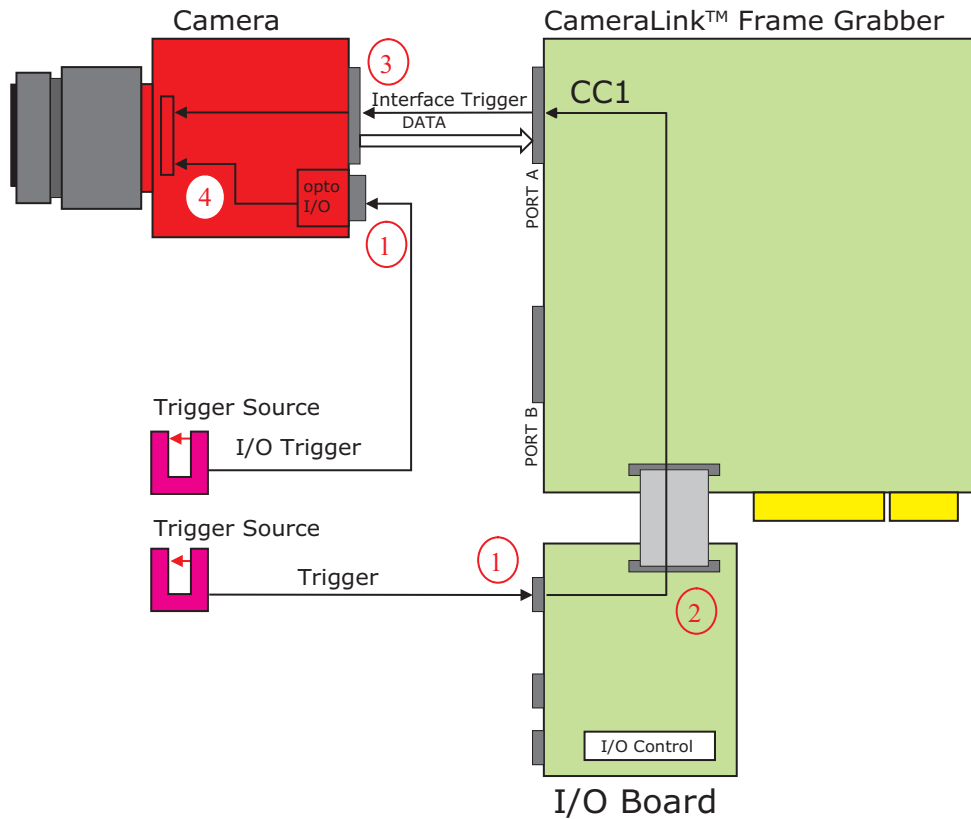

Figure 5.12: Trigger Delay visualisation from the trigger source to the camera

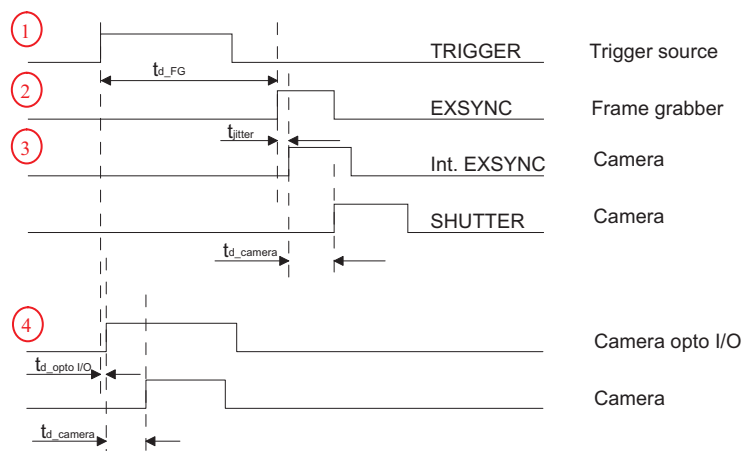

Figure 5.13: Timing Diagram for Trigger Delay

For the delay in the frame grabber, please ask your frame grabber manufacturer. The camera delay consists of a constant trigger delay and a variable delay (jitter).

Trigger delay type	Description
t_{d-FG}	Trigger delay of the frame grabber, refer to frame grabber manual
t_{jitter}	Variable camera trigger delay (max. 25 ns)
$t_{d-camera}$	Constant camera trigger delay (150 ns)
t_{d-opto}	Variable trigger delay of opto coupler

Table 5.5: Trigger Delay

The PFRemote Control Tool

6.1 Overview

PFRemote is a graphical configuration tool for Photonfocus cameras. The latest release can be downloaded from the support area of www.photonfocus.com.

All Photonfocus cameras can be either configured by PFRemote, or they can be programmed with custom software using the PFLib SDK ([PFLIB]).

6.1.1 CameraLink Model

As shown in Fig. 6.1, the camera parameters can be controlled by PFRemote and PFLib respectively. To grab an image use the software or the SDK that was delivered with your frame grabber.

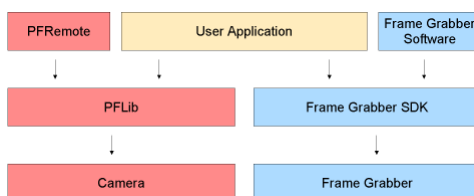

Figure 6.1: PFRemote and PFLib in context with the CameraLink frame grabber software

6.1.2 USB 2.0 Model

For the USB camera model, there is no external frame grabber necessary, as the camera connects directly to the USB 2.0 port. Instead, the frame grabber functionality was transferred into the camera.

As shown in Fig. 6.2, the camera parameters can be controlled by PFRemote and PFLib respectively. To grab an image use the MicroDisplayUSB software or the USB SDK.

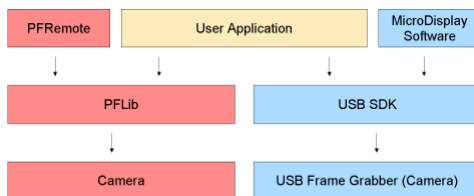

Figure 6.2: PFRemote and PFLib in context with the USB 2.0 frame grabber software



The USB isochronous interface mode (fast mode 48 MBytes/sec) works only with Windows XP and ServicePack 2 and an Intel Chipset!

6.2 Operating System

The PFRemote GUI is available for Windows OS only. For Linux or QNX operating systems, we provide the necessary libraries to control the camera on request, but there is no graphical user interface available.



If you require support for Linux or QNX operating systems, you may contact us for details of support conditions.

6.3 Installation Notes

For CameraLink Cameras: Before installing the required software with the PFInstaller, make sure that your frame grabber software is installed correctly.

For USB Cameras: Before installing the required software to control a Photonfocus camera with USB 2.0 interface, make sure that no USB camera is connected to the computer.

- During PFInstaller installation, choose "Install PFRemote with USB environment".
- After the installation, power on the camera and connect it to the USB interface.
- Windows should display the "New Hardware found" wizard automatically. If this wizard is not displayed, please continue as described in the following section.
- Let the hardware wizard install the drivers. It is not necessary to allow the search for current and updated software on the Internet. Proceed by choosing the option "Install the software automatically (Recommended)". Another hardware installation message will appear, which can be ignored ("Continue Anyway").



The procedure described above applies to Windows XP and Service pack 2.

6.3.1 Manual Driver Installation (only USB 2.0 Model)

If Windows did not automatically install the driver for your USB camera, please proceed as follows:

- Open the Device Manager in the Windows Control Panel.
- There will be an unknown device called "Silicon Software GmbH microUSB2".
- Right click on the unknown device and choose "Update driver".
- The hardware update wizard will appear. It is not necessary to allow the search for current and updated software on the internet. Click on "No, not this time" and "Next".
- Then choose "Install the software automatically (Recommended)" and proceed with "Next".
- When you get asked about the driver location, specify
`\Photonfocus\microDisplayUSB\driver`.



This procedure applies to Windows XP and Service pack 2.

6.3.2 DLL Dependencies

Several DLLs are necessary in order to be able to communicate with the cameras:

- PFCAM.DLL: The main DLL file that handles camera detection, switching to specific camera DLL and provides the interface for the SDK.
- 'CAMERANAME'.DLL: Specific camera DLL, e.g. mv_d1024e_40.dll.
- COMDLL.DLL: Communication DLL. This COMDLL is not necessarily CameraLink specific, but may depend on a CameraLink API compatible DLL, which should also be provided by your frame grabber manufacturer.
- CLALLSERIAL.DLL: Interface to CameraLink frame grabber which supports the clallserial.dll.
- CLSER_USB.DLL: Interface to USB port.

More information about these DLLs is available in the SDK documentation [SW002].

6.4 Graphical User Interface (GUI)

PFRremote consists of a main window (Fig. 6.3) and a configuration dialog. In the main window, the camera port can be opened or closed, and log messages are displayed at the bottom. The configuration dialog appears as a sub window as soon as a camera port was opened successfully. In the sub window of PFRremote the user can configure the camera properties. The following sections describe the general structure of PFRremote.

6.4.1 Port Browser

On start, PFRremote displays a list of available communication ports in the main window.

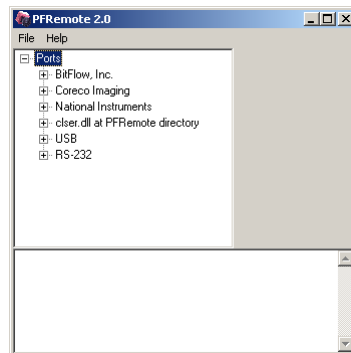

Figure 6.3: PFRremote main window with PortBrowser and log messages

To open a camera on a specific port double click on the port name (e.g. USB). Alternatively right click on the port name and choose **Open & Configure...**. The port is then queried for a compatible Photonfocus camera.

In the PFRremote main window, there are two menus with the following entries available:

File Menu

Clear Log: Clears the log file buffer

Quit: Exit the program

Help Menu

About: Copyright notice and version information

Help F1: Invoke the online help (PFRremote documentation)

6.4.2 Ports, Device initialization

After starting **PFRemote**, the main window as shown in Fig. 6.3 will appear. In the PortBrowser in the upper left corner you will see a list of supported ports.

-  Depending on the configuration, your port names may differ, and not every port may be functional.

-  If your frame grabber supports clallserial.dll version 1.1 (CameraLink compliant standard Oct 2001), the name of the manufacturer is shown in the PortBrowser.

-  If your frame grabber supports clallserial.dll version 1.0 (CameraLink compliant standard Oct 2000), the PortBrowser shows either the name of the dll or the manufacturer name or displays "Unknown".

-  If your frame grabber doesn't support clallserial.dll, copy the clserXXXX.dll of your frame grabber in the PFRemote directory and rename it to clser.dll. The PortBrowser will then indicate this DLL as "clser.dll at PFRemote directory".

After connecting the camera, the device can be opened with a double click on the port name or by right-clicking on the port name and choosing **Open & Configure**. If the initialisation of the camera was successful, the configuration dialog will open. The device is closed when PFRemote is closed. Alternatively, e.g. when connecting another camera or evaluation kit, the device can also be closed explicitly by right clicking on the port name and choosing **Close**. Make sure that the configuration dialog is closed prior to closing the port.

-  Errors, warnings or other important activities are logged in a log window at the bottom of the main window.

If the device does not open, check the following:

- Is the power LED of the camera active? Do you get an image in the display software of your frame grabber?
- Verify all cable connections and the power supply.
- Check the communication LED of the camera: do you see some activity when you try to access the camera?

6.4.3 Main Buttons

The buttons on the right side of the configuration dialog store and reset the camera configuration.

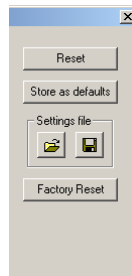

Figure 6.4: Main buttons

Reset: Reset the camera and load the default configuration.

Store as defaults: Store the current configuration in the camera flash memory as the default configuration. After a reset, the camera will load this configuration by default.

Settings file - File Load: Load a stored configuration from a file.

Settings file - File Save: Save current configuration to a file.

Factory Reset: Reset camera and reset the configuration to the factory defaults.

6.5 Device properties

Cameras or sensor devices are generally addressed as 'device' in this software. These devices have properties that are accessed by a property name. These property names are translated into register accesses on the driver DLL. The property names are reflected in the GUI as far as practicable. A property name normally has a special mark up throughout this document, for example: `ExposureTime`. Some properties are grouped into a structure whose member is accessed via dot notation, e.g. `Window.X` (for the start X value of a region of interest). When changing a property, the property name can always be seen in the log window of the main program window.

Graphical User Interface (GUI)

7.1 MV-D1024E-40

This section describes the parameters of the following cameras.

- MV-D1024E-40-CL, CameraLink interface
- MV-D1024E-40-U2, USB interface

The following sections are grouped according to the tabs in the configuration dialog.

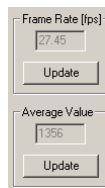

Figure 7.1: MV-D1024E-40 frame rate and average value

Frame Rate [fps :] Shows the actual frame rate of the camera in frames per second.

Update: To update the value of the frame rate, click on this button.

Average Value: Grayscale average of the actual image. This value is in 12bit (0...4095).

Update: To update the value of the average, click on this button.

7.1.1 Exposure

This tab contains exposure settings.

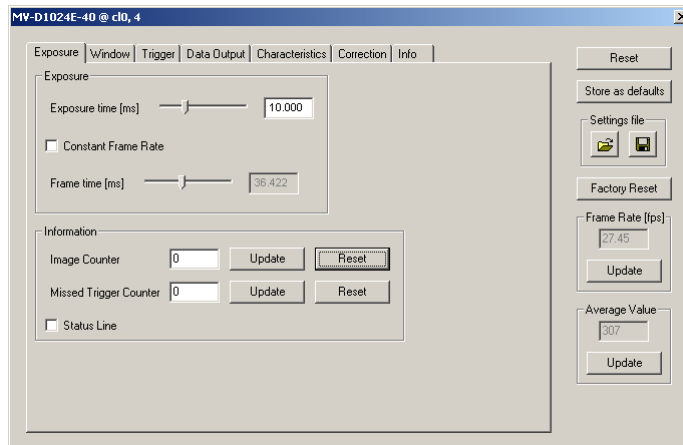

Figure 7.2: MV-D1024E-40 exposure panel

Exposure

Exposure time [ms :] Configure the exposure time in milliseconds.

Constant Frame Rate: When the Constant Frame Rate (CFR) is switched on, the frame rate (number of frames per second) can be varied from almost 0 up to the maximum frame rate. Thus, fewer images can be acquired than would otherwise be possible. When Constant Frame Rate is switched off, the camera delivers images as fast as possible, depending on the exposure time and the read-out time.

Frame time [ms :] Configure the frame time in milliseconds. Only available if Constant Frame Rate is enabled. The minimum frame time depends on the exposure time and readout time.

Information

The Information properties provide information about the acquired images.

Image Counter: The image counter is a 24 bit real-time counter and is incremented by 1 for every new image.

Missed Trigger Counter: This is a counter for trigger pulses that were blocked because the trigger pulse was received during image exposure or readout. In free-running mode it counts all pulses received from interface trigger or from I/O trigger interface.

Status Line: The status line replaces the last line of an image with image information.

To update the value of the information properties, click on the Update-Button; to reset the properties, click on the Reset-Button.

7.1.2 Window

This tab contains ROI, multi-ROI and decimation settings.

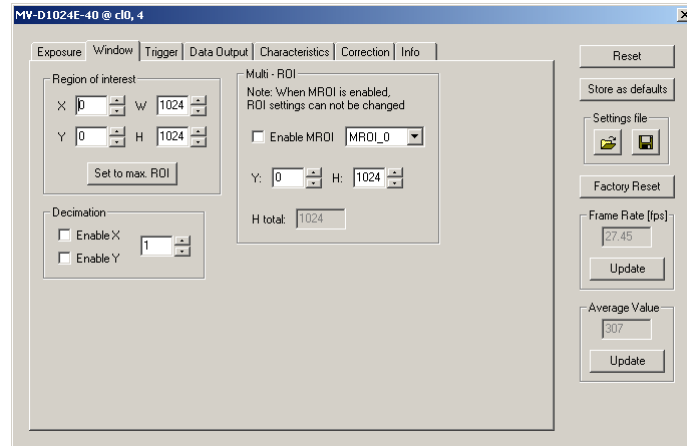

Figure 7.3: MV-D1024E-40 window panel

Region of Interest

The region of interest (ROI) is defined as a rectangle (X, Y), (W, H) where

X: X - coordinate, starting from 0 in the upper left corner.

Y: Y - coordinate, starting from 0 in the upper left corner.

W: Window width.

H: Window height.

Set to max ROI: Set Window to maximal ROI (X=0; Y=0; W=1024; H=1024).



For the MV-D1024E-40-U2 (USB camera): $W \times H > 1024$.

Decimation

Decimation reduces the number of pixels in x- or y-direction or both. Decimation can also be used together with a ROI or MROI. Decimation in y-direction transfers every n-th row only and directly results in reduced read-out time and higher frame rate respectively. Decimation in x-direction transfers every pixel of a row, but uses the CameraLink DVAL (data valid) signal to indicate which pixels to mask.



Please consult the documentation of your frame grabber on how to configure the frame grabber such that it interpretes the DVAL signal.

Enable X: Enable decimation in x-direction.

Enable Y: Enable decimation in y-direction.

Value: Decimation factor. Example: Value = 4 reads every fourth row and fourth column respectively only.

Multi - ROI

The MV-D1024E-40 cameras can handle up to 16 different regions of interest. The multiple ROIs are joined together and form a single image, which is transferred to the frame grabber. An ROI is defined by its starting value in y-direction and its height. The width and the horizontal offset are specified by X and W settings. The maximum frame rate in MROI mode depends on the number of rows and columns being read out. Overlapping ROIs are allowed, and the total height may exceed 1024 rows.

Enable MROI: Enable MROI. If MROI is enabled, the ROI and MROI settings cannot be changed.

MROI_X: Select one of the MROI settings.

Y: Y - coordinate of the selected MROI. If Y is set to 1023, this and all further MROI settings will be ignored.

H: Height of the selected MROI.

H tot: Shows the sum of all MROIs as the total image height.



After changing a property, always press Enter in order to make the change active.



For the MV-D1024E-40-U2 (USB camera): $W \times H_{tot} > 1024$.

7.1.3 Trigger

This tab contains trigger and strobe settings.

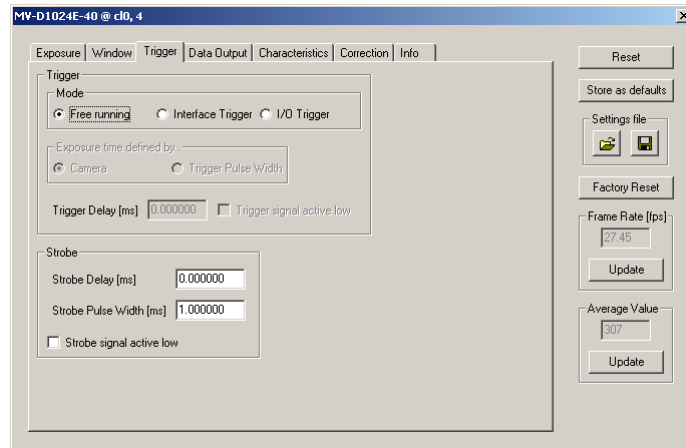

Figure 7.4: MV-D1024E-40 trigger panel

Trigger

Trigger Source:

Free running: The camera continuously delivers images with a certain configurable frame rate.

Interface Trigger: The Trigger signal is applied to the camera by the CameraLink frame grabber or the USB interface respectively.

I/O Trigger: The trigger signal is applied directly to the camera on the power supply connector.

Exposure time defined by:

Camera: The exposure time is defined by the property ExposureTime.

Trigger Pulse Width: The exposure time is defined by the pulse width of the trigger signal (level-controlled exposure).



This property disables LinLog.

Further trigger settings:

Trigger Delay: Programmable delay in milliseconds between the incoming trigger edge and the start of the exposure.

Trigger signal active low: Define the trigger signal to be active high (default) or active low.

Strobe

The camera generates a strobe output signal that can be used to trigger a strobe. The delay, pulse width and polarity can be defined by software. To turn off strobe output, set StrobePulseWidth to 0.

Strobe Delay [ms :] Delay in milliseconds from the input trigger edge to the rising edge of the strobe output signal.

Strobe Pulse Width [ms :] The pulse width of the strobe trigger in milliseconds.

Strobe signal active low: Define the strobe output to be active high (default) or active low.

7.1.4 Data Output

This tab contains image data settings.

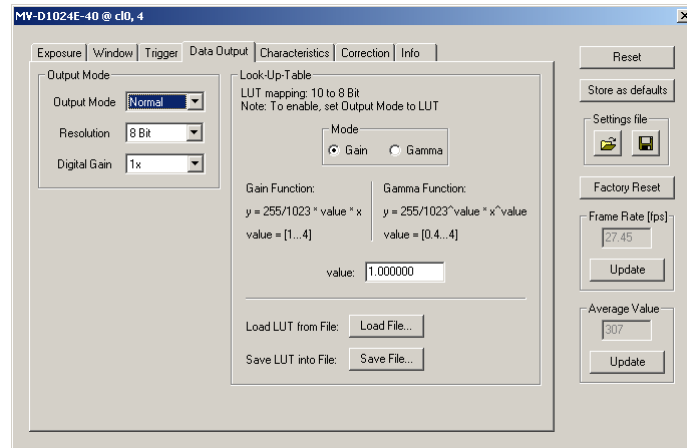

Figure 7.5: MV-D1024E-40 data output panel

Output Mode

Output Mode:

Normal: Normal mode.

LFSR: Test image. Linear feedback shift register (pseudo-random image). The pattern depends on the gray level resolution.

Ramp: Test image. Values of pixel are incremented by 1, starting at each row. The pattern depends on the gray level resolution.

LUT: Look-Up-Table, a 10-to-8-bit mapping of gray levels.

Resolution:

8 Bit: Gray level resolution of 8 bit.

10 Bit: Gray level resolution of 10 bit.

12 Bit: Gray level resolution of 12 bit.

Digital Gain:

1x: No digital gain, normal mode.

2x: Digital gain 2.

4x: Digital gain 4.

Look-Up-Table

Gray level transformation is remapping of the gray level values of an input image to new values which transform the image in some way. The look-up-table (LUT) is used to convert the grayscale value of each pixel in an image into another gray value. It is typically used to implement a transfer curve for contrast expansion.

The MV-D1024E-40 camera performs a 10-to-8-bit mapping, so that 1024 input gray levels can be mapped to 256 output gray levels (0 to 1023 and 0 to 255).

The default LUT is a gain function with value = 1.

Lut Mode:

Gain: Linear function. $Y = 255 / 1023 * \text{value} * X$; Valid range for value [1...4].

Gamma: Gamma function. $Y = 255 / 1023^{\text{value}} * X^{\text{value}}$; Valid range for value [0.4...4].

value: Enter a value. The LUT will be calculated and downloaded to the camera.

Load File...: Load a user defined LUT - file into the camera (*.txt tab delimited). There is an example in the PFRremote directory (mv_d1024e_40_lut.txt).

Save File...: Save LUT from camera into a file.

It is also possible to load a user LUT-file with missing input values (LUT-addresses). Then only pixel values corresponding to listed LUT entries will be overwritten. Example of a user defined LUT file:

Input Value	Output Value
0	0
1	0
2	0
3	1
4	1
5	1
6	1
7	2
8	2
9	2
10	2
11	3
12	3
13	3
14	3
15	4
16	4
17	4
18	4
19	5
20	5
21	5
22	5
23	6
24	6
25	6

Figure 7.6: Example of a user defined LUT file

7.1.5 Characteristics

This tab contains LinLog and Skimming settings.

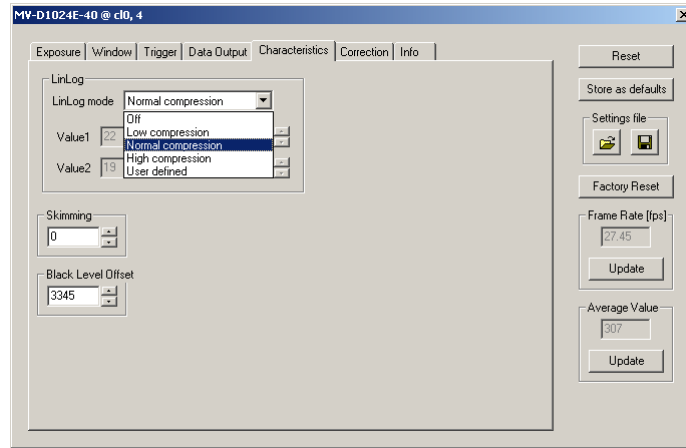

Figure 7.7: MV-D1024E-40 characteristics panel

LinLog

The LinLog technology from Photonfocus allows a logarithmic compression of high light intensities. In contrast to the classical non-integrating logarithmic pixel, the LinLog pixel is an integrating pixel with global shutter and the possibility to control the transition between linear and logarithmic mode (Section 4.3.2). There are 3 predefined LinLog settings available. Alternatively, custom settings can be defined in the User defined Mode.

LinLog Mode: Off: LinLog is disabled. Low/Normal/High compression: Three LinLog presettings. User defined: Value1, Time1, Value2 and Time2 (please read the User Manual for a more detailed explanation). The Linlog times are per thousand of the exposure time. Time 800 means 80% of the exposure time.

Skimming

Skimming is a Photonfocus proprietary technology to enhance detail in dark areas of an image.

Skimming: Skimming value. If 0, Skimming is disabled. See Section 4.3.3.

Black Level Offset

It may be necessary to adjust the black level offset of the camera.

Black Level Offset: Black level offset value. Use this to adjust the black level.

7.1.6 Correction

This tab contains correction settings.

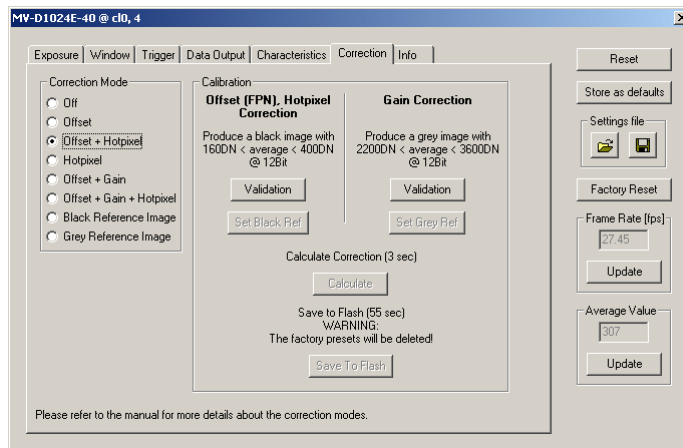

Figure 7.8: MV-D1024E-40 correction panel

Correction Mode

This camera has image pre-processing features, that compensate for non-uniformities caused by the sensor, the lens or the illumination.

Off: No correction.

Offset: Activate offset correction

Offset + Hotpixel: Activate offset and hot pixel correction.

Hotpixel: Activate hot pixel correction.

Offset + Gain: Activate offset and gain correction.

Offset + Gain + Hotpixel: Activate offset, gain and hot pixel correction.

Black Reference Image: Output the black reference image that is currently stored in the camera RAM (for debugging reasons).

Grey Reference Image: Output the grey reference image that is currently stored in the camera RAM (for debugging reasons).

Calibration

Offset (FPN), Hotpixel Correction: The offset correction is based on a black reference image, which is taken at no illumination (e.g. lens aperture completely closed). The black reference image contains the fixed-pattern noise of the sensor, which can be subtracted from the live images in order to minimize the static noise. Close the lens of the camera. Click on the Validation button. If the Set Black Ref - button is still inactive, the average of the image is out of range. Change to panel Characteristics and change the Property BlackLevelOffset until the average of the image is between 160 and 400DN. Click again on the Validation button and then on the Set Black Ref Button.



If only offset and hot pixel correction is needed it is not necessary to calibrate a gray image. (see Calculate)

Gain Correction: The gain correction is based on a gray reference image, which is taken at uniform illumination to give an image with a mid gray level.



Gain correction is not a trivial feature. The quality of the gray reference image is crucial for proper gain correction.

Produce a gray image with an average between 2200 and 3600DN. Click on the Validation button to check the average. If the average is in range, the Set Grey Ref button is active.

Calculate: Calculate the correction values into the camera RAM. To make the correction values permanent, use the 'Save to Flash' button.

Save to Flash: Save the current correction values to the internal flash memory.



This will overwrite the factory presets.

7.1.7 Info

This panel shows camera specific information such as type code, serial number and firmware revision of the FPGA and microcontroller and the description of the camera interface.

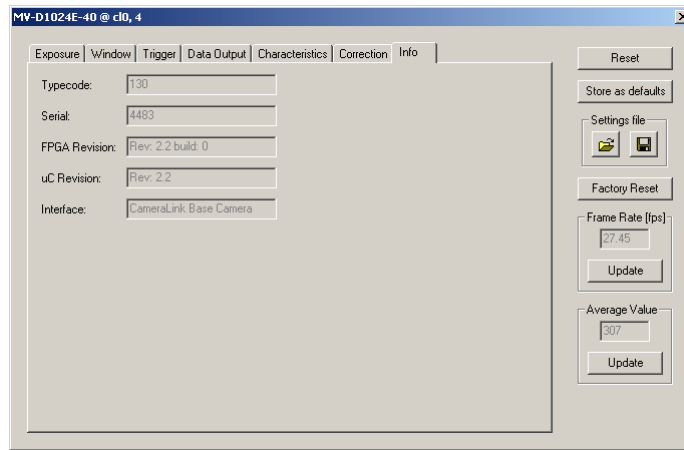

Figure 7.9: MV-D1024E-40 info panel

Typecode: Type code of the connected camera.

Serial: Serial number of the connected camera.

FPGA Revision: Firmware revision of built-in FPGA of the connected camera.

uC Revision: Firmware revision of built-in microcontroller of the connected camera.

Interface: Description of the camera interface.



For any support requests, please enclose the information provided on this tab.

7.2 MV-D1024E-80 and MV-D1024E-160

This section describes the parameters of the following cameras.

- MV-D1024E-80-CL, CameraLink interface
- MV-D1024E-160-CL, CameraLink interface

The following sections are grouped according to the tabs in the configuration dialog.

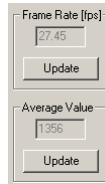

Figure 7.10: MV-D1024E-160 frame rate and average value

Frame Rate [fps :] Shows the actual frame rate of the camera in frames per second.

Update: To update the value of the frame rate, click on this button.

Average Value: Grayscale average of the actual image. This value is in 12bit (0...4095).

Update: To update the value of the average, click on this button.

7.2.1 Exposure

This tab contains exposure settings.

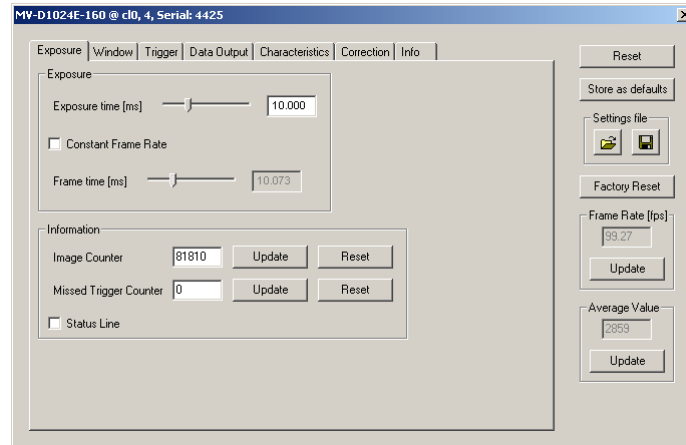

Figure 7.11: MV-D1024E-160 exposure panel

Exposure

Exposure time [ms :] Configure the exposure time in milliseconds.

Constant Frame Rate: When the Constant Frame Rate (CFR) is switched on, the frame rate (number of frames per second) can be varied from almost 0 up to the maximum frame rate. Thus, fewer images can be acquired than would otherwise be possible. When Constant Frame Rate is switched off, the camera delivers images as fast as possible, depending on the exposure time and the read-out time.

Frame time [ms :] Configure the frame time in milliseconds. Only available if Constant Frame Rate is enabled. The minimum frame time depends on the exposure time and readout time.

Information

The Information properties provide information about the acquired images.

Image Counter: The image counter is a 24 bit real-time counter and is incremented by 1 for every new image.

Missed Trigger Counter: This is a counter for trigger pulses that were blocked because the trigger pulse was received during image exposure or readout. In free-running mode it counts all pulses received from interface trigger or from I/O trigger interface.

Status Line: The status line replaces the last line of an image with image information.

To update the value of the information properties, click on the Update-Button; to reset the properties, click on the Reset-Button.

7.2.2 Window

This tab contains ROI, multi-ROI and decimation settings.

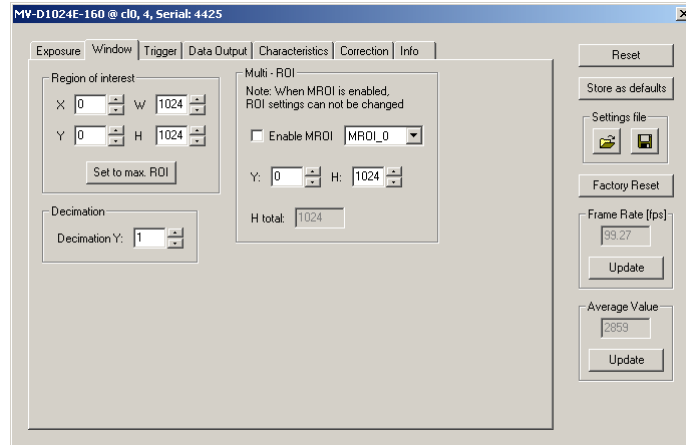

Figure 7.12: MV-D1024E-160 window panel

Region of Interest

The region of interest (ROI) is defined as a rectangle (X, Y), (W, H) where

X: X - coordinate, starting from 0 in the upper left corner.

Y: Y - coordinate, starting from 0 in the upper left corner.

W: Window width (in steps of 4 pixel).

H: Window height.

Set to max ROI: Set Window to maximal ROI (X=0; Y=0; W=1024; H=1024).



Window width is only available in steps of 4 pixel.

Decimation

Decimation reduces the number of pixels in y-direction. Decimation can also be used together with a ROI or MROI. Decimation in y-direction transfers every n-th row only and directly results in reduced read-out time and higher frame rate respectively.

Decimation Y: Decimation value for y-direction. Example: Value = 4 reads every fourth row only.

Multi - ROI

The MV-D1024E-80 and MV-D1024E-160 cameras can handle up to 16 different regions of interest. The multiple ROIs are joined together and form a single image, which is transferred to the frame grabber. An ROI is defined by its starting value in y-direction and its height. The width and the horizontal offset are specified by X and W settings. The maximum frame rate in

MROI mode depends on the number of rows and columns being read out. Overlapping ROIs are allowed, and the total height may exceed 1024 rows.

Enable MROI: Enable MROI. If MROI is enabled, the ROI and MROI settings cannot be changed.

MROI_X: Select one of the MROI settings.

Y: Y - coordinate of the selected MROI. If Y is set to 1023, this and all further MROI settings will be ignored.

H: Height of the selected MROI.

H tot: Shows the sum of all MROIs as the total image height.



After changing a property, always press Enter in order to make the change active.

7.2.3 Trigger

This tab contains trigger and strobe settings.

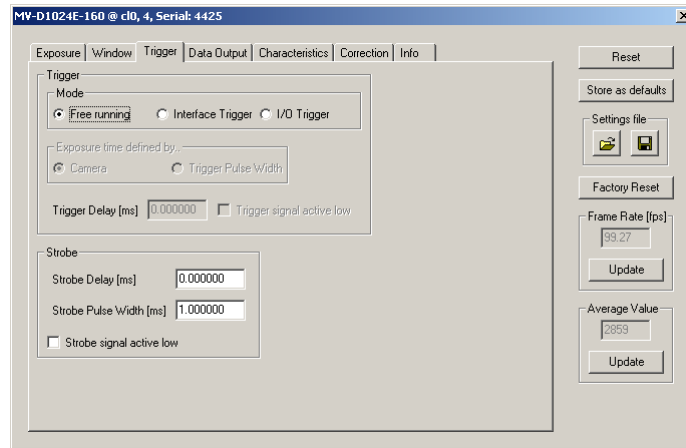

Figure 7.13: MV-D1024E-160 trigger panel

Trigger

Trigger Source:

Free running: The camera continuously delivers images with a certain configurable frame rate.

Interface Trigger: The Trigger signal is applied to the camera by the CameraLink frame grabber or the USB interface respectively.

I/O Trigger: The trigger signal is applied directly to the camera on the power supply connector.

Exposure time defined by:

Camera: The exposure time is defined by the property ExposureTime.

Trigger Pulse Width: The exposure time is defined by the pulse width of the trigger signal (level-controlled exposure).



This property disables LinLog and simultaneous readout mode.

Further trigger settings:

Trigger Delay: Programmable delay in milliseconds between the incoming trigger edge and the start of the exposure.

Trigger signal active low: Define the trigger signal to be active high (default) or active low.

Strobe

The camera generates a strobe output signal that can be used to trigger a strobe. The delay, pulse width and polarity can be defined by software. To turn off strobe output, set StrobePulseWidth to 0.

Strobe Delay [ms :] Delay in milliseconds from the input trigger edge to the rising edge of the strobe output signal.

Strobe Pulse Width [ms :] The pulse width of the strobe trigger in milliseconds.

Strobe signal active low: Define the strobe output to be active high (default) or active low.

7.2.4 Data Output

This tab contains image data settings.

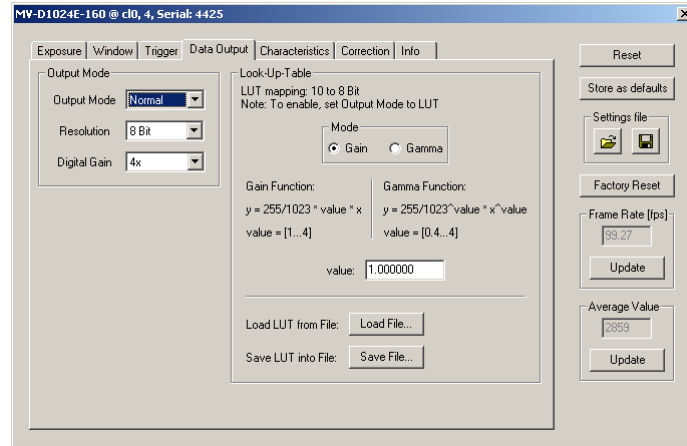

Figure 7.14: MV-D1024E-160 data output panel

Output Mode

Output Mode:

Normal: Normal mode.

LFSR: Test image. Linear feedback shift register (pseudo-random image). The pattern depends on the gray level resolution.

Ramp: Test image. Values of pixel are incremented by 1, starting at each row. The pattern depends on the gray level resolution.

LUT: Look-Up-Table, a 10-to-8-bit mapping of gray levels.

Resolution:

8 Bit: Gray level resolution of 8 bit.

10 Bit: Gray level resolution of 10 bit.

12 Bit: Gray level resolution of 12 bit.

Digital Gain:

1x: No digital gain, normal mode.

2x: Digital gain 2.

4x: Digital gain 4.

Look-Up-Table

Gray level transformation is remapping of the gray level values of an input image to new values which transform the image in some way. The look-up-table (LUT) is used to convert the grayscale value of each pixel in an image into another gray value. It is typically used to implement a transfer curve for contrast expansion.

The MV-D1024E-80 and the MV-D1024E-160 camera performs a 10-to-8-bit mapping, so that 1024 input gray levels can be mapped to 256 output gray levels (0 to 1023 and 0 to 255).

The default LUT is a gain function with value = 1.

Lut Mode:

Gain: Linear function. $Y = 255 / 1023 * \text{value} * X$; Valid range for value [1...4].

Gamma: Gamma function. $Y = 255 / 1023^{\text{value}} * X^{\text{value}}$; Valid range for value [0.4...4].

value: Enter a value. The LUT will be calculated and downloaded to the camera.

Load File...: Load a user defined LUT - file into the camera (*.txt tab delimited). There is an example in the PFRremote directory (mv_d1024e_80_lut.txt or mv_d1024e_160_lut.txt).

Save File...: Save LUT from camera into a file.

It is also possible to load a user LUT-file with missing input values (LUT-addresses). Then only pixel values corresponding to listed LUT entries will be overwritten. Example of a user defined LUT file:

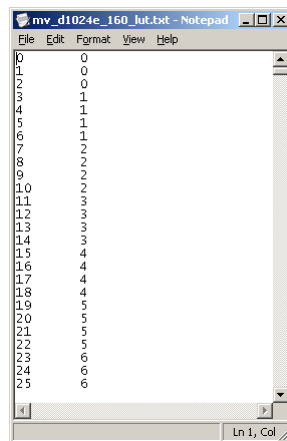

Figure 7.15: Example of a user defined LUT file

7.2.5 Characteristics

This tab contains LinLog and Skimming settings.

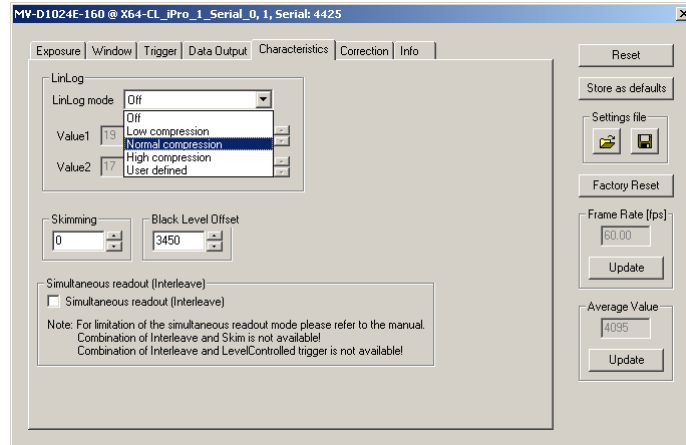

Figure 7.16: MV-D1024E-160 characteristics panel

LinLog

The LinLog technology from Photonfocus allows a logarithmic compression of high light intensities. In contrast to the classical non-integrating logarithmic pixel, the LinLog pixel is an integrating pixel with global shutter and the possibility to control the transition between linear and logarithmic mode (Section 4.3.2). There are 3 predefined LinLog settings available. Alternatively, custom settings can be defined in the User defined Mode.

LinLog Mode: Off: LinLog is disabled. Low/Normal/High compression: Three LinLog presets. User defined: Value1, Time1, Value2 and Time2. The Linlog times are per thousand of the exposure time. Time 800 means 80% of the exposure time.

Skimming

Skimming is a Photonfocus proprietary technology to enhance detail in dark areas of an image.

Skimming: Skimming value. If 0, Skimming is disabled. See Section 4.3.3.

Black Level Offset

It may be necessary to adjust the black level offset of the camera.

Black Level Offset: Black level offset value. Use this to adjust the black level.

Simultaneous readout (Interleave)

The simultaneous readout mode allows higher frame rate.

Simultaneous readout (Interleave): Enable the simultaneous readout mode.



Combination of property Trigger.Interleave and property Skim is not available! Combination of property Trigger.Interleave and property Trigger.LevelControlled is not available!

7.2.6 Correction

This tab contains correction settings.

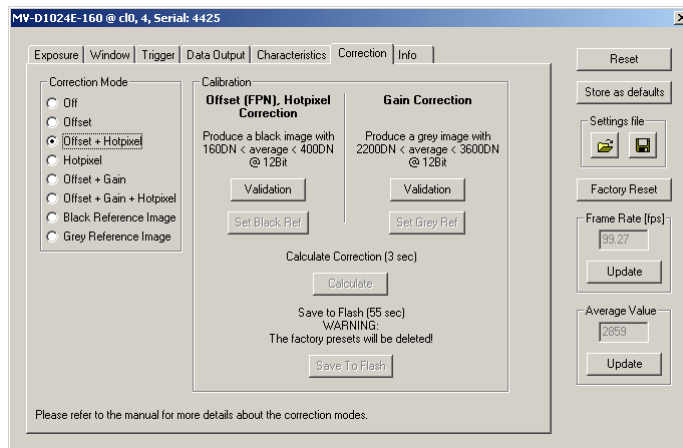

Figure 7.17: MV-D1024E-160 correction panel

Correction Mode

This camera has image pre-processing features, that compensate for non-uniformities caused by the sensor, the lens or the illumination.

Off: No correction.

Offset: Activate offset correction

Offset + Hotpixel: Activate offset and hot pixel correction.

Hotpixel: Activate hot pixel correction.

Offset + Gain: Activate offset and gain correction.

Offset + Gain + Hotpixel: Activate offset, gain and hot pixel correction.

Black Reference Image: Output the black reference image that is currently stored in the camera RAM (for debugging reasons).

Grey Reference Image: Output the grey reference image that is currently stored in the camera RAM (for debugging reasons).

Calibration

Offset (FPN), Hotpixel Correction: The offset correction is based on a black reference image, which is taken at no illumination (e.g. lens aperture completely closed). The black reference image contains the fixed-pattern noise of the sensor, which can be subtracted from the live images in order to minimize the static noise. Close the lens of the camera. Click on the Validation button. If the Set Black Ref - button is still inactive, the average of the image is out of range. Change to panel Characteristics and change the Property BlackLevelOffset until the average of the image is between 160 and 400DN. Click again on the Validation button and then on the Set Black Ref Button.



If only offset and hot pixel correction is needed it is not necessary to calibrate a gray image. (see Calculate)

Gain Correction: The gain correction is based on a gray reference image, which is taken at uniform illumination to give an image with a mid gray level.



Gain correction is not a trivial feature. The quality of the gray reference image is crucial for proper gain correction.

Produce a gray image with an average between 2200 and 3600DN. Click on the Validation button to check the average. If the average is in range, the Set Grey Ref button is active.

Calculate: Calculate the correction values into the camera RAM. To make the correction values permanent, use the 'Save to Flash' button.

Save to Flash: Save the current correction values to the internal flash memory.



This will overwrite the factory presets.

7.2.7 Info

This panel shows camera specific information such as type code, serial number and firmware revision of the FPGA and microcontroller and the description of the camera interface.

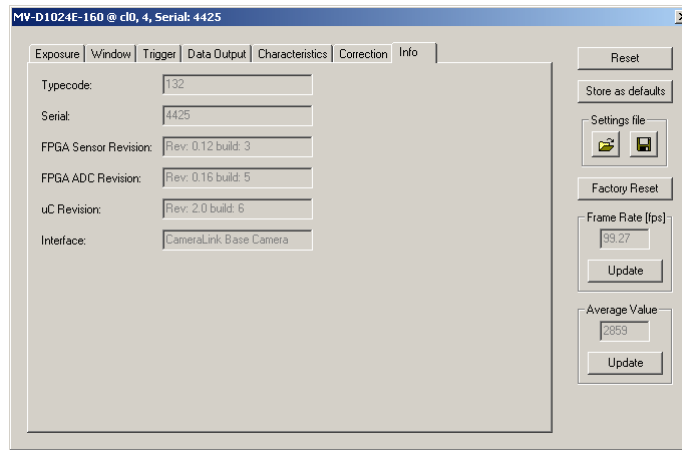

Figure 7.18: MV-D1024E-160 info panel

Typecode: Type code of the connected camera.

Serial: Serial number of the connected camera.

FPGA Sensor Revision: Firmware revision of built-in Sensor FPGA of the connected camera.

FPGA ADC Revision: Firmware revision of built-in ADC FPGA of the connected camera.

uC Revision: Firmware revision of built-in microcontroller of the connected camera.

Interface: Description of the camera interface.



For any support requests, please enclose the information provided on this tab.

Mechanical and Optical Considerations

8.1 Mechanical Interface

The general mechanical data of the cameras are listed in section 3, Table 3.4.

During storage and transport, the camera should be protected against vibration, shock, moisture and dust. The original packaging protects the camera adequately from vibration and shock during storage and transport. Please either retain this packaging for possible later use or dispose of it according to local regulations.

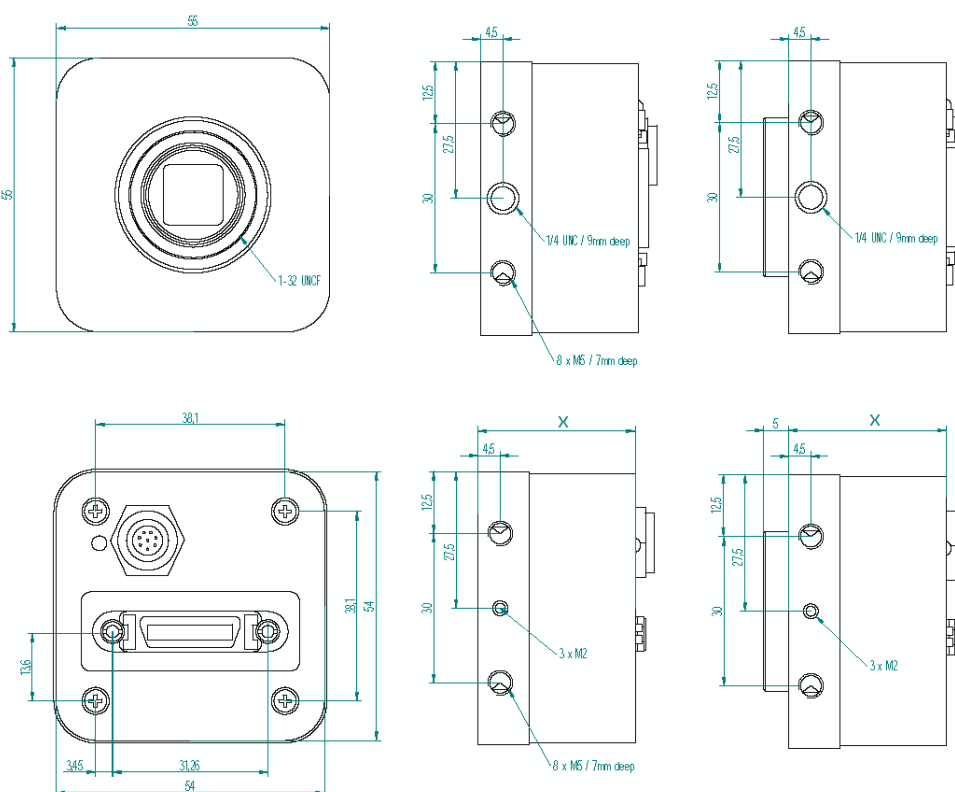

Figure 8.1: Mechanical dimensions of the CameraLink model with or without C-Mount adapter

All values are in [mm].

	MV-D1024E-40	MV-D1024E-80	MV-D1024E-160
X (housing depth)	32 mm	40 mm	40 mm

Table 8.1: Model-specific parameters

8.2 Optical Interface

8.2.1 Mounting the Lens

Remove the protective cap from the C-/CS-mount thread of the camera and install the lens. When removing the protective cap or changing the lens, the camera should always be held with the opening facing downwards to prevent dust from falling onto the CMOS sensor. If the lens is removed, the protective cap should be refitted. If the camera is operated in a dusty environment, we recommend the use of a constant stream of clean air in front of the objective.

8.2.2 Cleaning the Sensor

The sensor is part of the optical path and should be handled like other optical components: **with extreme care.**

Dust can obscure pixels, producing dark patches in the images captured. Dust is most visible when the illumination is collimated. Dark patches caused by dust or dirt shift position as the angle of illumination changes. Dust is normally not visible when the sensor is positioned at the exit port of an integrating sphere, where the illumination is diffuse.

1. The camera should only be cleaned in ESD-safe areas by ESD-trained personnel using wrist straps. Ideally, the sensor should be cleaned in a clean environment. Otherwise, in dusty environments, the sensor will immediately become dirty again after cleaning.
2. Use a high quality, low pressure air duster (e.g. Electrolube EAD400D, pure compressed inert gas, www.electrolube.com) to blow off loose particles. This step alone is usually sufficient to clean the sensor of the most common contaminants.



Workshop air supply is not appropriate and may cause permanent damage to the sensor.

3. If further cleaning is required, use a suitable lens wiper or Q-Tip moistened with an appropriate cleaning fluid to wipe the sensor surface as described below. Examples of suitable lens cleaning materials are given in Table 8.2. Cleaning materials must be ESD-safe, lint-free and free from particles that may scratch the sensor surface.



Do not use ordinary cotton buds. These do not fulfil the above requirements and permanent damage to the sensor may result.

4. Wipe the sensor carefully and slowly. First remove coarse particles and dirt from the sensor using Q-Tips soaked in 2-propanol, applying as little pressure as possible. Using a method similar to that used for cleaning optical surfaces, clean the sensor by starting at any corner of the sensor and working towards the opposite corner. Finally, repeat the procedure with methanol to remove streaks. It is imperative that no pressure be applied to the surface of the sensor or to the black globe-top material (if present) surrounding the optically active surface during the cleaning process.

Product		Supplier	Remark
EAD400D	Airduster	Electrolube, UK	www.electrolube.com
Anticon Gold 9"x 9"	Wiper	Milliken, USA	ESD safe and suitable for class 100 environments. www.milliken.com
TX4025	Wiper	Texwipe	www.texwipe.com
Transplex	Swab	Texwipe	
Small Q-Tips SWABS BB-003	Q-tips	Hans J. Michael GmbH, Germany	www.hjm.de
Large Q-Tips SWABS CA-003	Q-tips	Hans J. Michael GmbH, Germany	
Point Slim HUBY-340	Q-tips	Hans J. Michael GmbH, Germany	
Methanol	Fluid	Johnson Matthey GmbH, Germany	Semiconductor Grade 99.9% min (Assay), Merck 12,6024, UN1230, slightly flammable and poisonous. www.alfa-chemcat.com
2-Propanol (Iso-Propanol)	Fluid	Johnson Matthey GmbH, Germany	Semiconductor Grade 99.5% min (Assay) Merck 12,5227, UN1219, slightly flammable. www.alfa-chemcat.com

Table 8.2: Recommended materials for sensor cleaning

For cleaning the sensor, Photonfocus recommends the products available from the suppliers as listed in Table 8.2.



Cleaning tools (except chemicals) can be purchased from Photonfocus (www.photonfocus.com).

8.3 Compliance

CE Compliance Statement

We,

**Photonfocus AG,
CH-8853 Lachen, Switzerland**

declare under our sole responsibility that the following products

MV-D1024-28-CL-10, MV-D1024-80-CL-8, MV-D1024-160-CL-8

MV-D752-28-CL-10, MV-D752-80-CL-8, MV-D752-160-CL-8

**MV-D640-33-CL-10, MV-D640-66-CL-10, MV-D640-48-U2-8
MV-D640C-33-CL-10, MV-D640C-66-CL-10, MV-D640C-48-U2-8**

**MV-D1024E-40, MV-D752E-40, MV-D750E-20 (CameraLink and
USB2.0 Models), MV-D1024E-80, MV-D1024E-160**

MV-D1024E-PP01

MV2-D1280-640-CL-8

SM2-D1024-80

**DS1-D1024-40-CL, DS1-D1024-40-U2,
DS1-D1024-80-CL, DS1-D1024-160-CL**

Digipeater CLB26

are in compliance with the below mentioned standards according to
the provisions of European Standards Directives:

EN 61 000 - 6 - 3 : 2001

EN 61 000 - 6 - 2 : 2001

EN 61 000 - 4 - 6 : 1996

EN 61 000 - 4 - 4 : 1996

EN 61 000 - 4 - 3 : 1996

EN 61 000 - 4 - 2 : 1995

EN 55 022 : 1994

Photonfocus AG, December 2007

Figure 8.2: CE Compliance Statement

Warranty

The manufacturer alone reserves the right to recognize warranty claims.

9.1 Warranty Terms

The manufacturer warrants to distributor and end customer that for a period of two years from the date of the shipment from manufacturer or distributor to end customer (the "Warranty Period") that:

- the product will substantially conform to the specifications set forth in the applicable documentation published by the manufacturer and accompanying said product, and
- the product shall be free from defects in materials and workmanship under normal use.

The distributor shall not make or pass on to any party any warranty or representation on behalf of the manufacturer other than or inconsistent with the above limited warranty set.

9.2 Warranty Claim



The above warranty does not apply to any product that has been modified or altered by any party other than manufacturer, or for any defects caused by any use of the product in a manner for which it was not designed, or by the negligence of any party other than manufacturer.

References

All referenced documents can be downloaded from our website at www.photonfocus.com.

CL CameraLink Specification, October 2000

SW002 PFLib Documentation, Photonfocus, August 2005

AN001 Application Note "LinLog", Photonfocus, December 2002

AN024 Application Note "LinLog - Principle and Practical Example", Photonfocus, March 2005

AN007 Application Note "Camera Acquisition Modes", Photonfocus, March 2004

AN010 Application Note "Camera Clock Concepts", Photonfocus, July 2004

AN021 Application Note "CameraLink", Photonfocus, July 2004

AN026 Application Note "LFSR Test Images", Photonfocus, September 2005

10 References

Pinouts

11.1 Power Supply

The power supply plugs are available from Binder connectors at www.binder-connector.de.



It is extremely important that you apply the appropriate voltages to your camera. Incorrect voltages will damage or destroy the camera.



A suitable power supply is available from Photonfocus.

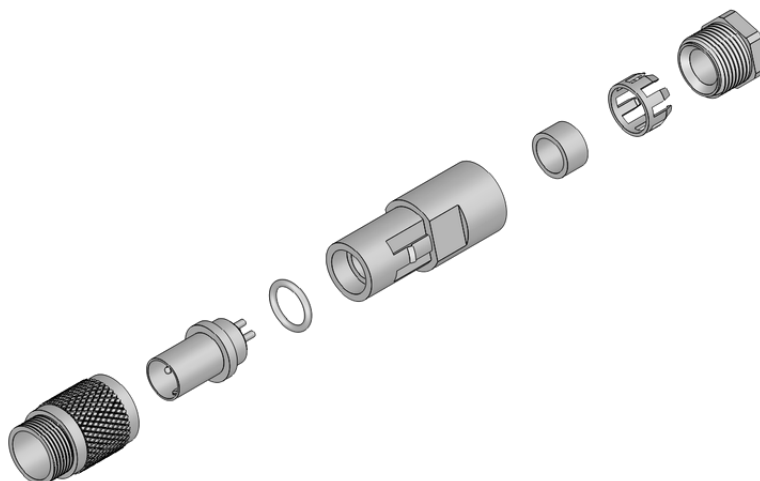

Figure 11.1: Power connector assembly

11.1.1 Power Supply Connector

Connector Type	Order Nr.
7-pole, plastic	99-0421-00-07
7-pole, metal	99-0421-10-07

Table 11.1: Power supply connectors (Binder subminiature series 712)

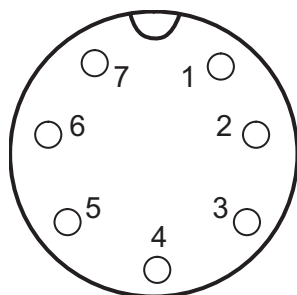

Figure 11.2: Power supply plug, 7-pole (rear view of plug, solder side)

Pin	I/O Type	Name	Description
1	PWR	VDD	+12 V DC ($\pm 10\%$)
2	PWR	GND	Ground
3	O	RESERVED	Do not connect
4	PWR	STROBE-VDD	+5 .. +15 V DC
5	O	STROBE	Strobe control (opto-isolated)
6	I	TRIGGER	External trigger (opto-isolated), +5 .. +15V DC
7	PWR	GROUND	Signal ground (for opto-isolated strobe signal)

Table 11.2: Power supply plug pin assignment

11.2 CameraLink Connector

The pinout for the CameraLink 26 pin, 0.5" Mini D-Ribbon (MDR) connector is according to the CameraLink standard ([CL]) and is listed here for reference only (see Table 11.3). The drawing of the CameraLink cable plug is shown in Fig. 11.3. CameraLink cables can be purchased from Photonfocus directly (www.photonfocus.com).

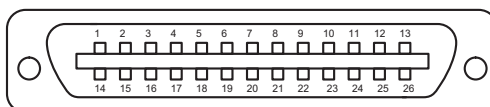

Figure 11.3: CameraLink cable 3M MDR-26 plug (both ends)

PIN	IO	Name	Description
1	PW	SHIELD	Shield
2	O	N_XD0	Negative LVDS Output, CameraLink Data D0
3	O	N_XD1	Negative LVDS Output, CameraLink Data D1
4	O	N_XD2	Negative LVDS Output, CameraLink Data D2
5	O	N_XCLK	Negative LVDS Output, CameraLink Clock
6	O	N_XD3	Negative LVDS Output, CameraLink Data D3
7	I	P_SERTOCAM	Positive LVDS Input, Serial Communication to the camera
8	O	N_SERTOFG	Negative LVDS Output, Serial Communication from the camera
9	I	N_CC1	Negative LVDS Input, Camera Control 1 (CC1)
10	I	N_CC2	Positive LVDS Input, Camera Control 2 (CC2)
11	I	N_CC3	Negative LVDS Input, Camera Control 3 (CC3)
12	I	P_CC4	Positive LVDS Input, Camera Control 4 (CC4)
13	PW	SHIELD	Shield
14	PW	SHIELD	Shield
15	O	P_XD0	Positive LVDS Output, CameraLink Data D0
16	O	P_XD1	Positive LVDS Output, CameraLink Data D1
17	O	P_XD2	Positive LVDS Output, CameraLink Data D2
18	O	P_XCLK	Positive LVDS Output, CameraLink Clock
19	O	P_XD3	Positive LVDS Output, CameraLink Data D3
20	I	N_SERTOCAM	Negative LVDS Input, Serial Communication to the camera
21	O	P_SERTOFG	Positive LVDS Output, Serial Communication from the camera
22	I	P_CC1	Positive LVDS Input, Camera Control 1 (CC1)
23	I	N_CC2	Negative LVDS Input, Camera Control 2 (CC2)
24	I	P_CC3	Positive LVDS Input, Camera Control 3 (CC3)
25	I	N_CC4	Negative LVDS Input, Camera Control 4 (CC4)
26	PW	SHIELD	Shield
S	PW	SHIELD	Shield

Table 11.3: Pinout CameraLink connector

Revision History

Revision	Date	Changes
1.0	August 2005	First release
1.1	October 2005	Removed USB model, separated into new manual.
1.11	February 2006	Updated frame rate formula
1.17	February 2007	MV-D1024E-80/160 included, rename of Hurricane
1.3	March 2008	Update of conformity statement